

# TC-K333ESL/K970ES

## SERVICE MANUAL

AEP Model  
TC-K970ES

E Model  
TC-K333ESL

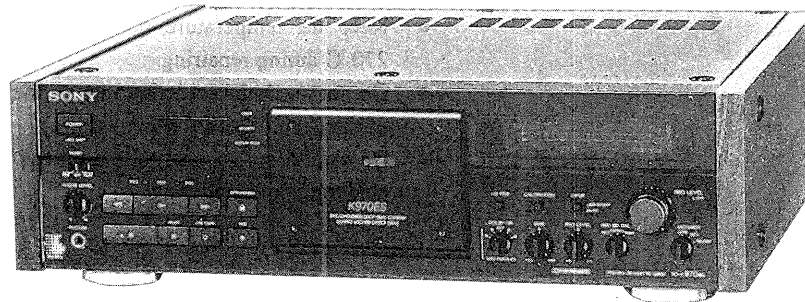

\* Dolby noise reduction and HX Pro headroom extension manufactured under license from Dolby Laboratories Licensing Corporation. HX Pro originated by Bang & Olufsen.

"DOLBY", the double-D symbol  and "HX PRO" are trademarks of Dolby Laboratories Licensing Corporation.

Model Name Using Similar Mechanism	TC-K333ESG
Tape Transport Mechanism Type	TCM-200D4

### SPECIFICATIONS

Recording system 4-track 2-channel stereo  
Fast winding time Approx. 90 sec. (with Sony C-60 cassette)  
Bias AC bias  
Heads Erasing head × 1 (S&F head)  
Recording head × 1 (LA head)  
Playback head × 1 (LA head)  
Motors Capstan motor × 1  
(direct-drive linear torque BSL motor)  
Reel motor × 1 (DC motor)  
DC motor × 1

Signal-to-noise ratio (at peak level)

Cassette	Dolby NR switch		
	OFF	B-Type ON	C-Type ON
Type IV (Sony METAL-S)	61 dB	70 dB	76 dB
Type II (Sony UX-S)	59 dB	68 dB	74 dB
Type I (Sony HF-S)	57 dB	66 dB	72 dB

Total harmonic distortion 1.0% (with Sony METAL-S cassettes)

Frequency response (DOLBY NR OFF)

Type IV cassette (Sony METAL-S)	15 - 22,000 Hz (±3 dB, IEC) 15 - 16,000 Hz [±3 dB OVU(-4dB)recording]
Type II cassette (Sony UX-S)	15 - 20,000 Hz (±3 dB, IEC)
Type I cassette (Sony HF-S)	15 - 18,000 Hz (±3 dB, IEC)

Wow and flutter ±0.04% W.Peak (IEC)  
0.024% WRMS (NAB)  
±0.065% W.Peak (DIN)

#### Inputs

Line inputs (phono jacks)	Sensitivity	77.5 mV
	Input impedance	47 k ohms
CD DIRECT INPUT	Input impedance	47 k ohms

#### Outputs

Line outputs (phono jacks)	Rated output level	0,44 V at a load impedance of 47 k ohms
	Load impedance	Over 10 k ohms
Phones (stereo phone jack)	Output level	0 - 2,5 mW at a load impedance of 32 ohms

#### General

Power requirements 120-220-240V AC, 50/60Hz (AEP, Germany)  
220-230V AC, 50/60Hz (E)

Power consumption 31 W

Dimensions Approx. 470 × 140 × 380 mm (w/h/d)  
(18 $\frac{5}{8}$  × 5 $\frac{5}{8}$  × 15 inches)

Weight including projecting parts and controls  
Approx. 12.0 kg (17 lbs 7 oz)  
Model for other countries: Approx. 11.2 kg

#### Supplied accessory

Audio connecting cord (2)  
Screws(8)  
Wireless remote control unit\*  
Sony R6 (Size-AA) batteries (2)\*

\*Not supplied with model for AEP countries

Design and specifications subject to change without notice.



STEREO CASSETTE DECK  
**SONY**<sup>®</sup>

TABLE OF CONTENTS

<u>Section</u>	<u>Title</u>	<u>Page</u>
SPECIFICATIONS		1
MODEL IDENTIFICATION		3
<b>1. GENERAL</b>		4
<b>2. DISASSEMBLY</b>		8
<b>3. ADJUSTMENTS</b>		
3-1. Mechanical Adjustments		10
3-2. Electrical Adjustments		12
<b>4. DIAGRAMS</b>		
4-1-1. IC502, 505 (CX20188) Pin Functions		17
4-1-2. IC601 (M50940-313SP) Pin Functions		18
4-1-3. IC801 (M50964-220SP) Pin Functions		19
4-1-4. IC881 (HD404240A80S) Pin Functions		20
4-2. Circuit Boards Location		20
4-3. IC Block Diagrams		21
4-4. Semiconductor Lead Layouts		22
4-5. Block Diagram		23
4-6. Printed Wiring Boards		
- Audio Section -		27
4-7. Schematic Diagram		
- Audio Section -		31
4-8. Schematic Diagram		
- Syscon Section -		35
4-9. Printed Wiring Boards		
- Syscon Section -		39
<b>5. EXPLODED VIEWS</b>		
5-1. Overall Section		43
5-2. Front Panel Section		44
5-3. Chassis Section		45
5-4. Mechanism Section-1		
(TCM-200D4)		46
5-5. Mechanism Section-2		
(TCM-200D4)		47
<b>6. ELECTRICAL PARTS LIST</b>		48

Notes on chip component replacement

- Never reuse a disconnected chip component.
- Notice that the minus side of a tantalum capacitor may be damaged by heat.

Flexible Circuit Board Repairing

- Keep the temperature of the soldering iron around 270°C during repairing.
- Do not touch the soldering iron on the same conductor of the circuit board (within 3 times).
- Be careful not to apply force on the conductor when soldering or unsoldering.

TC-K333ESL : E Model

**Operating Voltage**

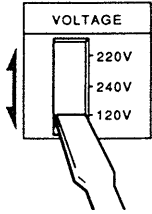

Before connecting the unit to the power source, check that the operational voltage of your unit is the same as the local power supply.

Where purchased	Operating voltage
European countries	220 – 230 V AC, 50/60 Hz
Other countries	120, 220 or 240 V AC adjustable, 50/60 Hz A voltage selector is located on the rear panel. If the selector must be reset, <b>disconnect the AC power cord</b> and set the selector to the appropriate voltage.



VOLTAGE selector

**SAFETY-RELATED COMPONENT WARNING!!**

COMPONENTS IDENTIFIED BY MARK  OR DOTTED LINE WITH MARK  ON THE SCHEMATIC DIAGRAMS AND IN THE PARTS LIST ARE CRITICAL TO SAFE OPERATION. REPLACE THESE COMPONENTS WITH SONY PARTS WHOSE PART NUMBERS APPEAR AS SHOWN IN THIS MANUAL OR IN SUPPLEMENTS PUBLISHED BY SONY.

**For higher quality recording/playback**

- **The Dolby HX PRO\* system** which improves the linearity of the tape's high-range response during recording.
- **Bias and recording level calibration** which ensures optimum recording conditions to bring out the best in every tape.
- **Three-head system (separate recording, playback and erase heads)** which allows you to instantly check the recorded sound while recording is in progress.
- **Professional-level deck design** for high mechanical stability and maximum performance.

**For your convenience**

- **The AMS and Memory Play functions** which provide easy access to a desired selection.
- **Timer-activated playback and recording** through the use of an optional timer.

**For easier operation**

- **Easy-to-read digital linear counter** which shows the elapsed recording or playing time.

**MODEL IDENTIFICATION**

— Specification Label —

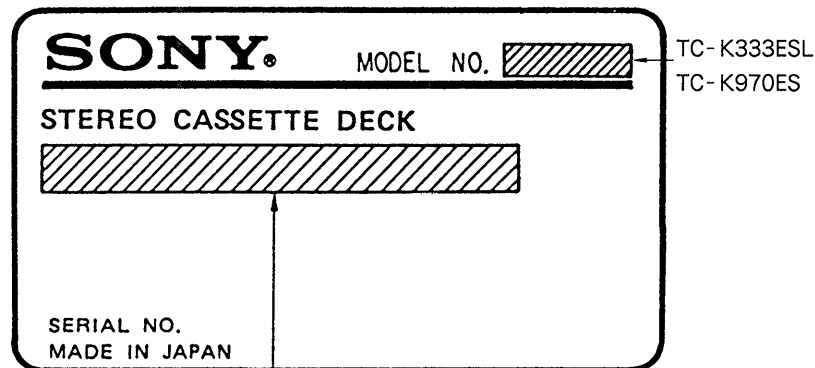
AEP, G Model : 220  $\sim$  50/60Hz 31WE Model : 120, 220, 240V  $\sim$  50/60Hz 31W



**SECTION 1  
GENERAL**

This section is extracted from instruction manual.

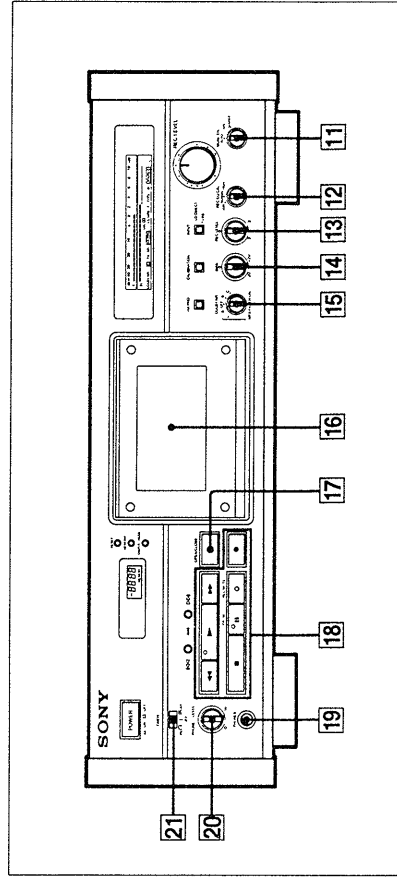
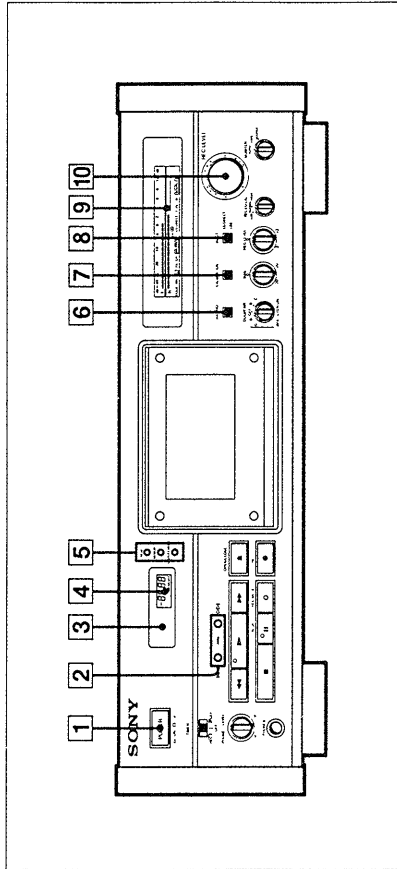
**Identification of Front Panel Parts**



For details, refer to the page number indicated in ●.

- 1 POWER switch
- 2 AMS (Automatic Music Sensor) buttons ●
- 3 Remote sensor  
You can remotely control this cassette deck with:  
— A remote commander that came with a Sony amplifier or receiver if it has the  mark and cassette deck control capability.  
— An optional Sony remote commander with the  mark and cassette deck control capability.
- 4 LINEAR COUNTER ●
- 5 Counter buttons  
RESET button ●  
MEMORY button ● ●  
DISPLAY MODE button ●
- 6 DOLBY HX PRO button ● ●
- 7 CALIBRATION button ●
- 8 INPUT button ●
- 9 PEAK PROGRAM METER ●
- 10 REC (recording) LEVEL control ● ●  
*(Continued on next page.)*

For details, refer to the page number indicated in ●.

*(Continued from previous page.)*

- 11 MONITOR switch ●
- 12 REC EQ CAL (recording equalizing calibration) switch (LOW, NORMAL, HIGH) ●
- 13 REC (recording) LEVEL control for calibration ● ●
- 14 BIAS control ● ●
- 15 DOLBY NR (noise reduction)/MPX FILTER switch ● ●
- 16 Cassette holder
- 17 OPEN/CLOSE button
- 18 Tape operation buttons and indicators  
◀◀ (rewind) button  
■ (stop) button  
▶▶ (play) button and indicator  
▶ (fast-forward) button  
● REC (recording) button and indicator  
|| PAUSE button and indicator  
○ REC MUITE (record muting) button ●
- 19 PHONES jack (stereo phone jack) ●
- 20 PHONE (headphones) LEVEL control
- 21 TIMER switch ●

# Making an Optimum Recording According to the Tape Type

## Bias and Recording Level Calibration

There are many different types of cassettes on the market, each with varying magnetic properties. Although your unit is equipped with the ATS (Automatic Tape Selection) system which sets the appropriate equalization characteristics and bias current for each tape type, an additional calibration adjustment can often produce even better results. Use the bias current and recording level calibration function to obtain the optimum recording conditions for your tape.

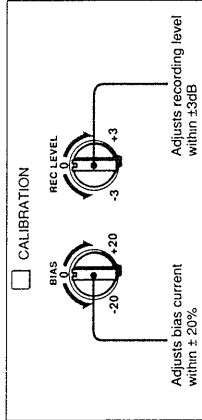

**Bias calibration**  
 Choosing the optimum bias current for a tape ensures minimum distortion and flat frequency response. Lowering the bias current boosts high-frequency response, but also results in higher distortion. Raising the bias, on the other hand, reduces distortion, but also dampens high-frequency response. Optimum bias is thus obtained when the bias current and high-frequency response are well balanced.

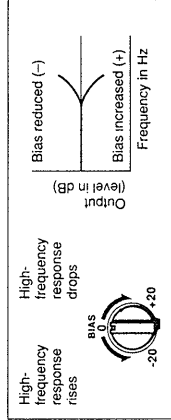

- If the bias current is higher or lower than the optimum setting for a certain tape, the frequency response changes as shown in the chart above. Changing the bias can thus be used to tailor the response to your liking, for example by slightly emphasizing the upper or lower end.
- The frequency response of metal tapes is much less affected by changes in the bias current than other tape types. With some tapes, the adjustment range of this deck (±20%) may therefore not be sufficient to cover every possible requirement.

**Recording level calibration**  
 Even when the recording level is adjusted correctly, using a tape with low sensitivity will result in a low playback level. The REC LEVEL calibration control allows you to compensate for sensitivity differences among tapes to equalize both recording and playback levels. This is especially important when using the Dolby NR system, since it is most effective when recording and playback levels are the same.

# Remote Commander

(Except for European model)

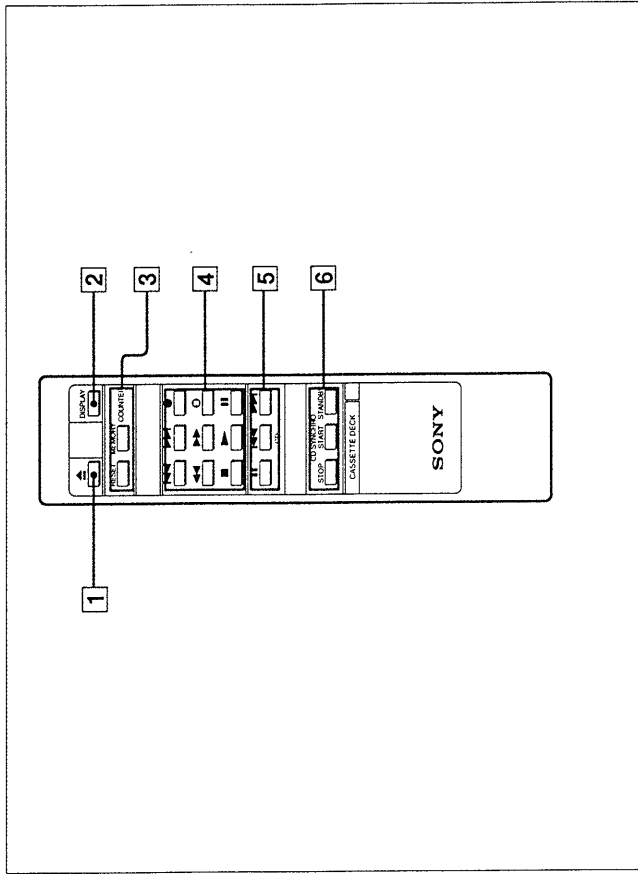

The controls on the remote commander are identical in function and operation to those with the same name on the main unit.

For details, refer to the page number indicated in ●.

- 1 ● (open/close) button
- 2 ● DISPLAY button
- 3 ● Counter buttons
- 4 ● Tape operation buttons
- 5 ● CD (Compact Disc) buttons for controlling Sony CD players
- 6 ● CD SYNCHRO buttons for synchronized recording with a Sony CD player

# Making an Optimum Recording According to the Tape Type

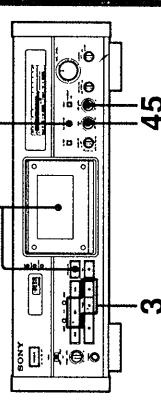

**1** Insert the cassette to be used for recording.

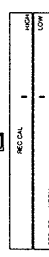

**2** Press CALIBRATION.

**3** Activate the recording test tones:

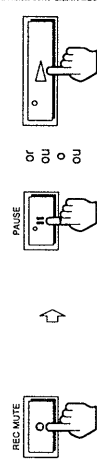

or



Playback level for an 8-kHz signal

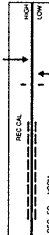

Playback level for a 400-Hz signal

**4** Adjust BIAS until both meters indicate equal playback levels.

A high reading on the upper meter indicates a low bias current.

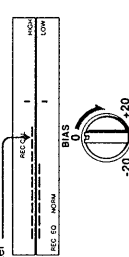

A low reading on the upper meter indicates a high bias current.

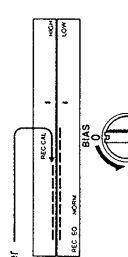

An equal reading on both meters indicates the optimum bias current condition.

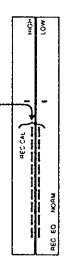

**5** Adjust REC LEVEL CALIBRATION until both meters reach the recommended level (REC CAL).

The bias current is now adjusted to the optimum level and the tape sensitivity compensation has been set. Press CALIBRATION to OFF. Rewind the tape and start the actual recording.



Recommended level

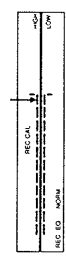

**Note**

- The sound cannot be monitored during the calibration operation.
- It takes 2 to 3 seconds to stabilize the test tone level.

## Making an Optimum Recording According to the Tape Type

### Recording Equalization Calibration

Although bias current and equalization are automatically set by the Automatic Tape Selection (ATS) function for the tape being used, you can use the REC EQ CAL switch to change the recording characteristics according to the nature of the source material or to compensate for the particular characteristics of the tape.

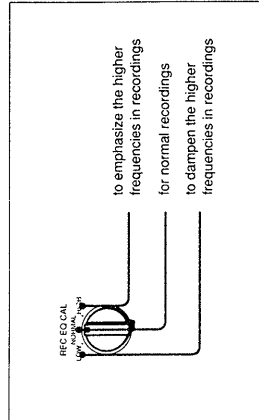

#### Bias Calibration Recording

To modify bands of sound as required, use the REC EQ CAL switch in conjunction with bias calibration, which enables you to record according to the tape's characteristics.

- **When recording music which has strong middle and low frequencies**  
Set the bias at flat with the REC EQ CAL switch set in the HIGH position to increase the bias current.  
Adjust BIAS so that the HIGH and LOW meters indicate equal readings.
- **When recording music which has strong high frequencies**  
Set the bias at flat with the REC EQ CAL switch set in the LOW position to decrease the bias current.  
Adjust BIAS so that the HIGH and LOW meters indicate equal readings.

#### Note

With metal tape, because the amount of frequency characteristic modulation is not in proportion to that of the bias, the optimum bias current may not be obtained using the methods above.

#### Another use of the REC EQ CAL switch

When using a special tape, the BIAS control with the REC EQ CAL switch set in the NORMAL position may not cause the HIGH and LOW meters to indicate equal readings. If this occurs, adjust the BIAS control after setting the REC EQ CAL switch to HIGH or LOW.

## Recording

### What is the Dolby HX PRO System?

The Dolby HX PRO system provides improved linearity in high-range frequency response during recording. Tapes recorded with this system retain the same high quality even when played back on other tape decks.

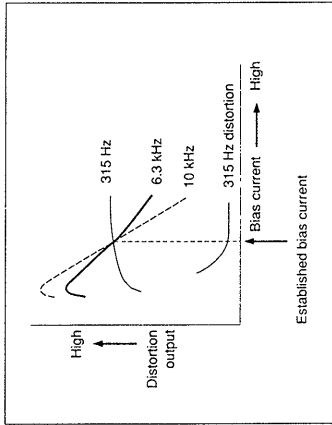

As shown above, characteristics such as output level and distortion differ widely according to the bias (high-frequency) current. In conventional systems, the bias current is susceptible to variations in certain recording signals (see diagram below) which may cause fluctuations in frequency response, distortion, or other unwanted characteristics.

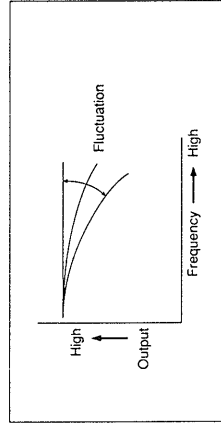

With the Dolby HX PRO system, the effective bias amount added to the bias current is controlled in millisecond units to greatly reduce distortion, improving linearity in high-range response and ensuring high-intensity recording with minimal distortion and noise.

## SECTION 2 DISASSEMBLY

• If the parts are marked with the numbers ①, etc., remove them in the order of the number.

### Cassette Holder

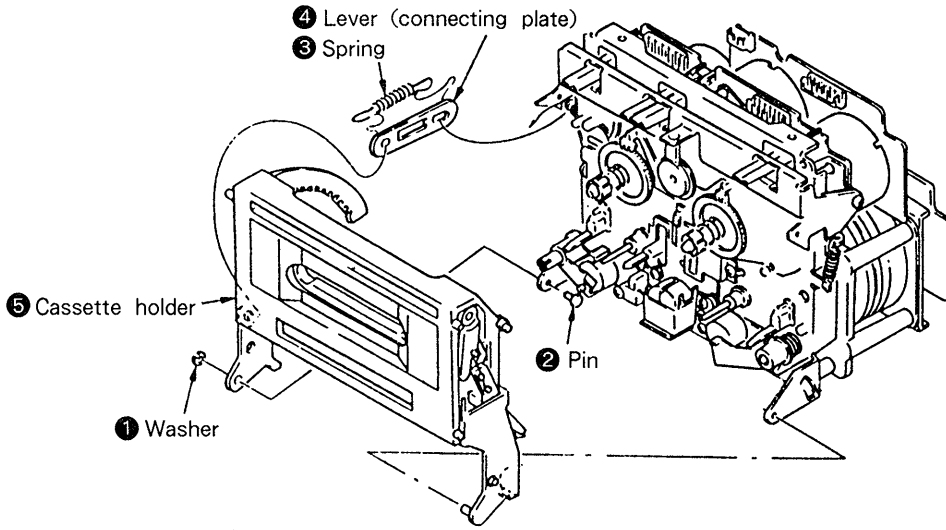

### Ornamental Plate

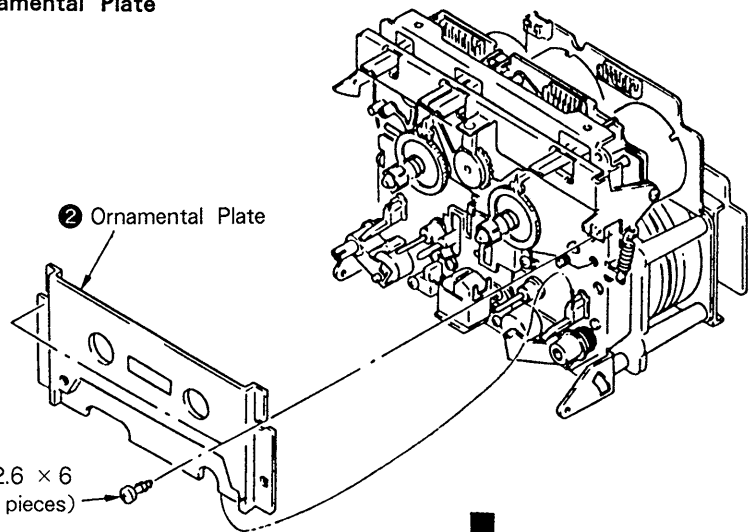

### Pinch Lever/Lever FR

- ① - ④ : Pinch lever S
- ① and ② : Pinch lever T
- △ and △ : Lever FR

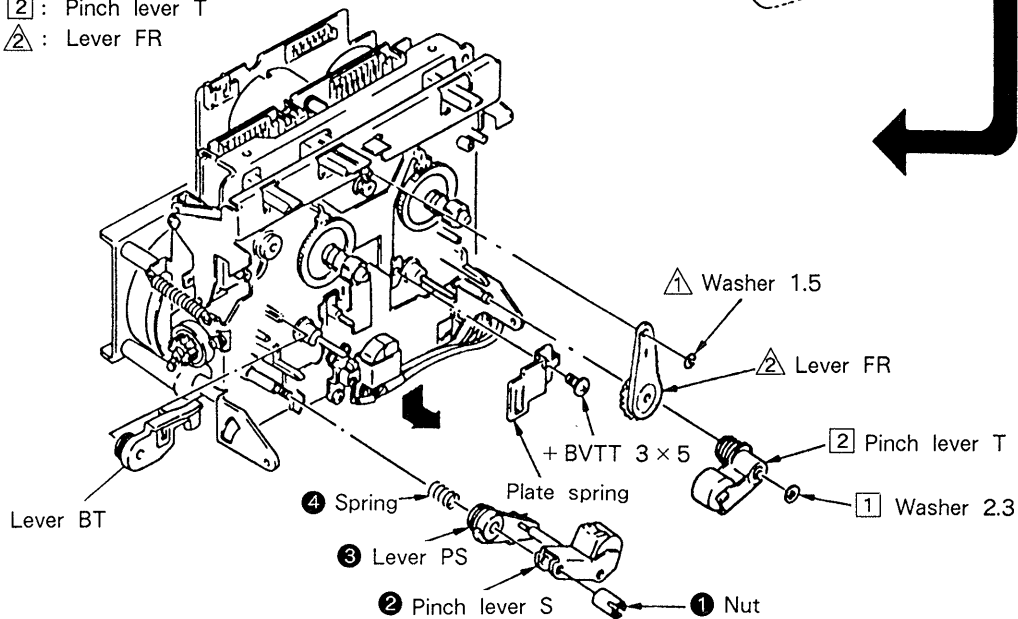



**Comparator Board/Capstan Board/Flywheel/FG Board**

△ and ▽ : Comparator board

① - ④ : Capstan board

① - ③ : FG board (after removing 1 and 2)

Note : To remove the above parts with the base (D1) assembly, remove the four screws marked with ★.

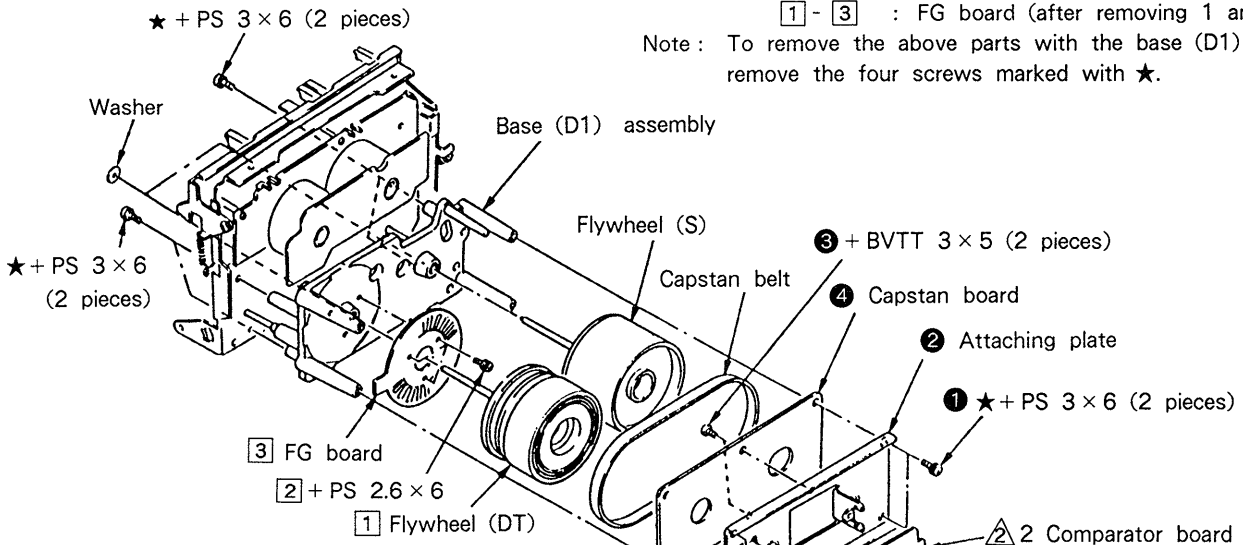

**MD board**

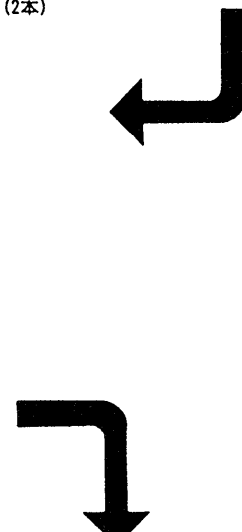
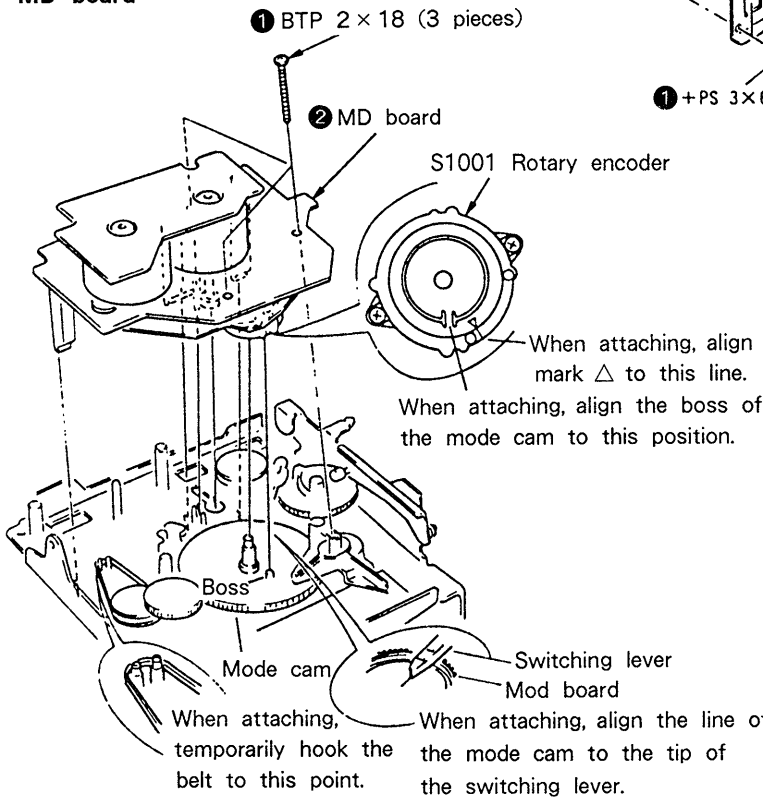

**Reel Motor Board**

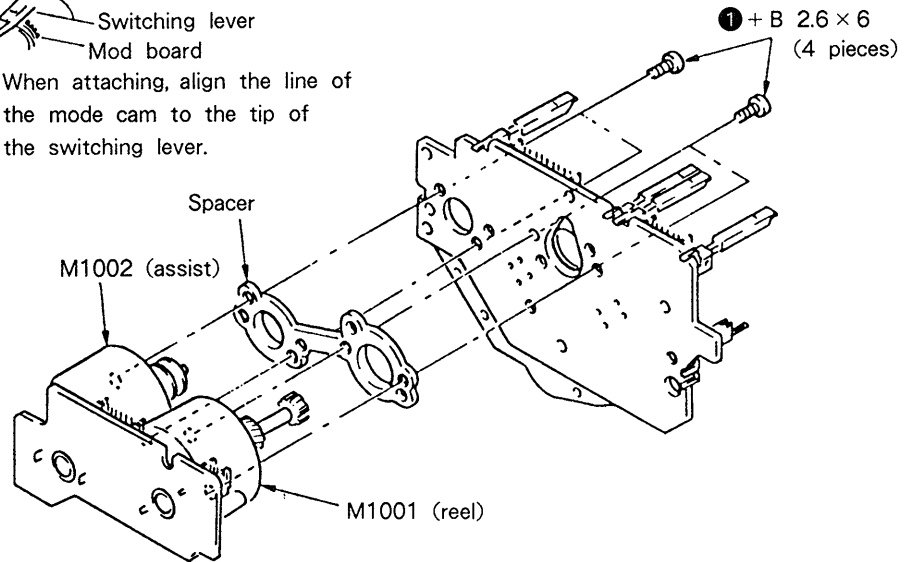

## SECTION 3 ADJUSTMENTS

### 3-1. MECHANICAL ADJUSTMENTS

#### PRECAUTION

1. Clean the following parts with a denatured-alcohol-moistened swab:
 

record/playback head	pinch roller
erase head	rubber belts
capstan	idlers
2. Demagnetize the record/playback and erase head with a head demagnetizer.
3. Do not use a magnetized screwdriver for the adjustments.
4. After the adjustments, apply suitable locking compound to the parts adjusted.
5. The adjustments should be performed with the rated power supply voltage unless otherwise noted.

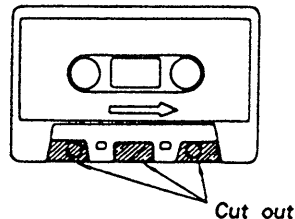

2. Phillips screwdriver (medium-size):  
For the head adjustment screws  
Blade-type screwdriver (large-size):  
For the supply pinch roller adjustment screws
3. Pen light
4. WS-48B (3 kHz, 0 dB)
5. P-4-A100 (10 kHz, -10 dB)

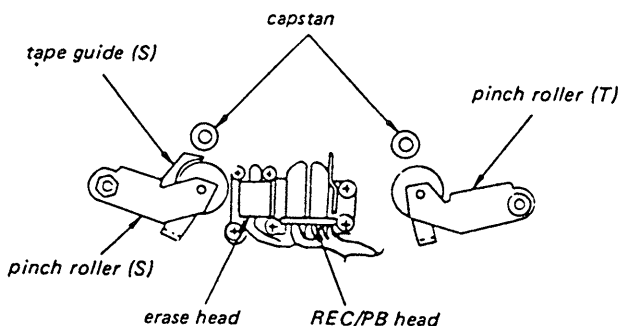

Definition of Terms: The figures are of a record/playback head.

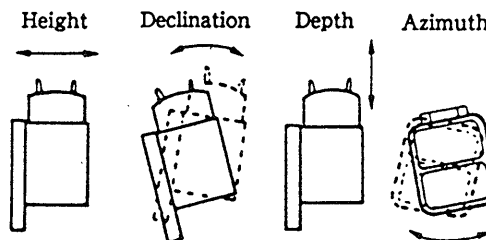

#### Adjustment Method:

##### Supply Pinch Roller

**Note:** Only perform this adjustment when the supply pinch roller is to be replaced.

1. Insert the mirror cassette and put the unit in record/playback mode.
2. Check to see whether the tape is curling at the record/playback head guide or the pinch roller guide.  
If it is curling, remove the curl by adjusting the  $\odot$  tape curl adjustment screw. Then, check that the tape is running past the middle of the erasehead.

##### Record/playback Head

**Note:** Only perform this adjustment when the record/playback head is to be replaced.

1. Insert the mirror cassette and put the unit in record/playback mode.
2. (**Height Adjustment**) Check to see if the tape is curling at the tape guide of the head. If it is curling, tighten screws  $\odot$ ,  $\ominus$ , and  $\odot$ , respectively by the same angle, moving the head so that it

#### Tape Path Adjustment

- Refer to Adjustment Position on page 12.

**Note:** When using the adjustment methods for other than replacement reasons, please do not tamper unnecessarily with the adjustment screws or the erasehead because either the supply pinch roller guide or the record/playback head will be made the standard tape paths. Moreover, when it is necessary to adjust and replace two or more of any of the heads and/or pinch rollers, replace them one by one, completely taking out the first tape path, and then replacing the second one.

#### Preparation:

1. Mirror cassette CQ009C 8-909-708-01  
(or CQ012C 8-909-708-02)

If one does not have this, cut out the sections of a 120-minute cassette shell as indicated below and use that cassette.

remains at the same angle throughout the procedure. If it curls on the bottom side of the mirror cassette (actually the inner side), tighten all the screws equally; but loosen them if the tape begins to curl on the top side (outer side).

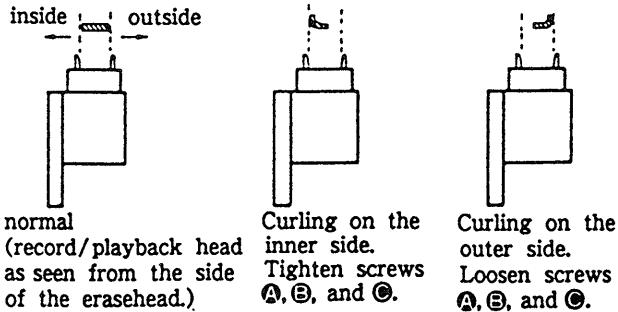

- (Declination Adjustment) While in the record/playback position, set the back tension to 0 (wind the supply reel with something thin like a pencil in a counterclockwise direction) and make sure there is no curling or shifting (shifting up/shifting down) at the guide of the record/playback head.

Because shifting can only occur due to a difference in the width of the tape and that of the tape guides (curling will otherwise occur), it is necessary to pay close attention since it can be easily overlooked. When there is a shift, tighten screws B and C equally and change the declination of the head. If the tape is shifting up, tighten the screws, and if it is shifting down, loosen them.

- Repeat the adjustments in steps 2 and 3 and fine adjust the height and the declination.
- (Preliminary Azimuth Adjustment) After demagnetizing and cleaning the adjustment head, play back WS-48B (3 kHz, 0 dB). Turn screw C so that the reading on the level meter of the unit or that of the level meter connected to LINE OUT is maximized. If the screw is turned at least half a revolution, repeat the adjustments from step 1.

- (Tape Path Check) Connect the oscilloscope to LINE OUT and play back P-4-A100 (10 kHz, -10 dB) to display a resurge waveform. After 20 seconds of record/playback (after the tension within the loop has been increased sufficiently), make sure the variation in the resurge is within  $\pm 90$  degrees (within  $\pm 45$  degrees is desired). If the variation is greater than this, it is because the declination and/or the height adjustment is not perfect. Repeat the adjustments from step 1.

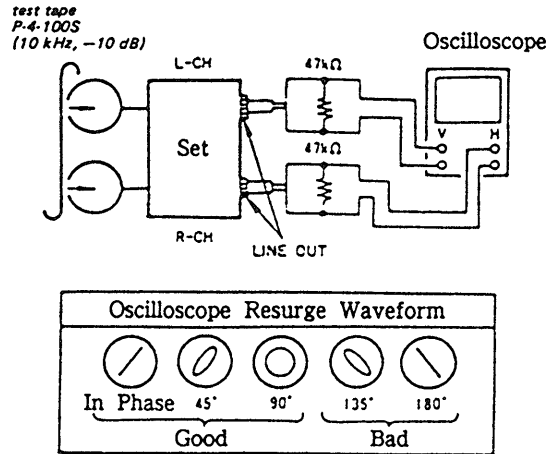

**Erasehead**

**Note:** Only perform this adjustment when the erasehead is to be replaced.

- Insert the mirror cassette and put the unit in record/playback mode.
- (Azimuth Adjustment) Adjust the azimuth of the erasehead by adjusting screws B and C so that the tape runs as evenly as possible.

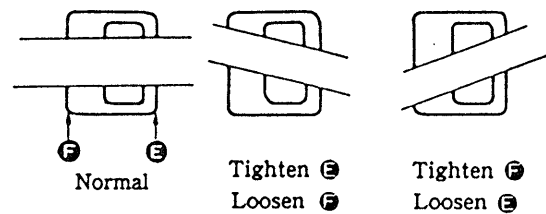

(The erasehead as seen when erasing the mirror cassette.)

- (Height adjustment) Turn screws D, B, and C all by the same angle so that the portions of the erasehead visible at top and bottom are nearly of equal width. If the width at the top is greater, tighten the screws; if the width at the bottom is greater, loosen the screws.

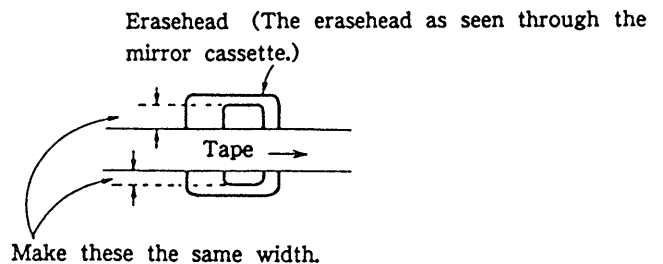

4. (Declination Adjustment) Leaving it in the playback position, put the back tension to 0 and make certain the erasehead part and supply pinch roller guide part do not shift. If there is a shift, turn the screw ⑩ and change the declination. Looking at it using the mirror cassette, if the tape shifts up, tighten the screw, and if it shifts down, loosen the screw.
5. Repeat the adjustments beginning with step 2 and fine adjust the height and declination. And make sure the tape does not curl up on the pinch roller guide or the guide part of the record/playback head.
6. (Depth Adjustment) In order to make the entire head play the tape smoothly, and to make sure the depth of the erasehead is neither too shallow nor too deep, loosen screw ⑨ a bit.

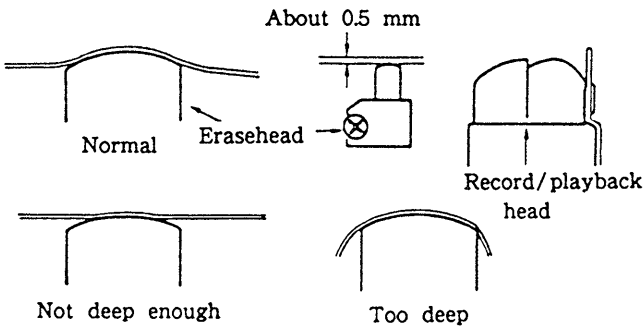

**Check**

1. Check to make sure that there are no curls or shifts throughout the whole tape path and that the tape runs smoothly.
2. Reapply the locking compound to the adjusted screws. (The locking compound should only be applied to screw ⑨ after the azimuth has been adjusted.)

**Adjustment Position :** As seen from the cassette, side (top) and MD as seen head on (bottom).

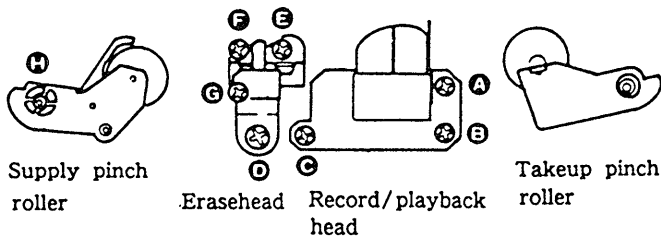
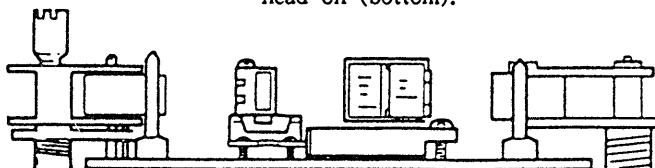

**Pinch Roller Pressing Force Measurement**

Mode : playback

Hook needle of the tension gauge to the pinch roller shaft and push back pinch roller to detach it from capstan. Then, return it gradually to capstan and read the gauge when the pinch roller begins turning.

**Standard Limits :**

Tape-up side : 270 - 350g (9.5 - 12oz)

Supply side : 180 - 280g (6.4 - 9.9oz)

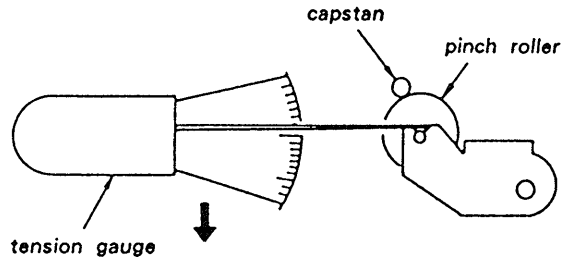

**3-2. ELECTRICAL ADJUSTMENTS**

**Note:** The adjustment should be performed in the order given in this service manual.

The adjustments should be performed for both L-CH and R-CH.

- Simultaneous REC/PB Mode:  
Input the signals to LINE IN terminal and set to REC mode. Set the monitor switch to TAPE, and monitor the recorded signal from LINE OUT terminal.
- Switch Position:  
DOLBY NR..... OFF  
TIMER..... OFF  
MONITOR..... TAPE  
HX PRO ..... OFF  
CALIBRATION..... OFF  
CD DIRECT..... OFF  
BIAS ..... CENTER CLICK  
REC LEVEL ..... CENTER CLICK

- Standard Record:  
Deliver the standard input signal level to the input jack and set the REC LEVEL control to obtain the standard output signal level.

Standard Input Level

Input Terminal	LINE IN
source impedance	10 kΩ
input level	0.25 V (-10 dB)

**Standard Output Level**

Output Terminal	LINE OUT
load impedance	47 kΩ
output level	0.44 V (-5 dB)

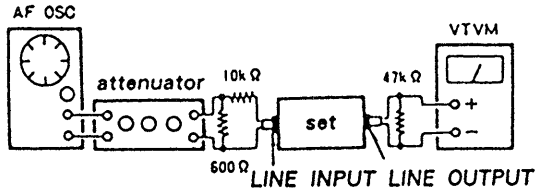

**Torque Adjustment and Measurement**

1. Insert a tape for torque measurement, CQ-102C, and put the set to PLAY mode. Adjust RV801 so that the reading of the torque meter is  $40 \pm 5g \cdot cm$ .
2. After the adjustment, measure the back-tension and the FF/REW torque and check that the following specifications are satisfied.

Torque	Torque Meter	Reading
FWD	CQ-102C	35 - 45g · cm (0.49 - 0.64oz · inch)
FWD Back tension	CQ-102C	7 - 12g · cm (oz · inch)
FF/REW	CQ-201B	55 - 120g · cm (0.97 - 1.67oz · inch)

**Tape Speed/WOW Check**

**Procedure:**

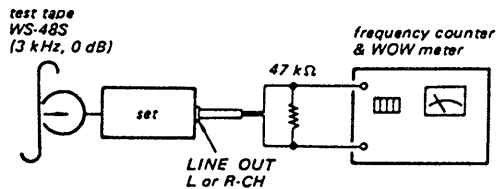

1. Measure the output frequency and the WOW value while playing back the tape top of the test tape.
2. Turn over the test tape, measure the output frequency and the WOW value, and check the difference from the values of the step 1.

**Adjustment Limits :**

TAPE SPEED deviation:	within 2,990 to 3,010 Hz
TAPE SPEED fluctuating width:	within 2,990 to 3,010 Hz
WOW (WRMS):	0.037 % or less

**MPX FILTER Check**

**Setting :** DOLBY switch : OFF  
MPX FILTER switch : OFF

**Procedure :**

1. Mode: stop

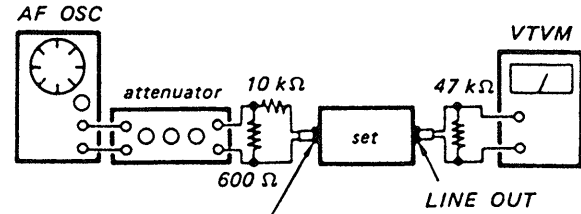

LINE IN  
315 Hz, 0.25 V (-10dB)

2. Apply 315Hz, 0.25V (-10dB) signal and adjust REC LEVEL (RV501) control so that the LINE OUT level is 0.44V (-5dB).
3. Apply 19kHz 0.25V (-10dB) signal and confirm that the LINE OUT level is 0.013V (-35dB) or less.

**Adjustment Limits :**

DOLBY NR switch : B or C  
MPX FILTER switch : Line output level when ON.  
315Hz : Within 0.49 to 0.39V (within -4dB to -6dB)  
19kHz : 0.013V (-35dB) or less

**Record/Playback Head Azimuth Adjustment**

**Procedure :**

1. Mode : playback

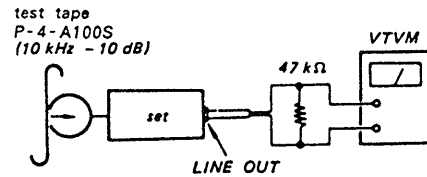

2. Turn the adjustment screw for the maximum output levels. If these levels do not match, turn the adjustment screw until both of output levels match together within 0.5dB.

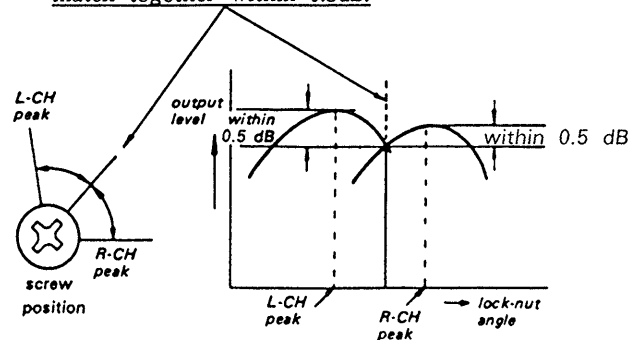

**Adjustment Location :**

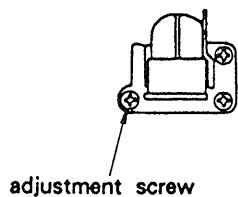

**Playback Level Adjustment**

**Procedure:**

Mode: playback

test tape  
P-4-L300  
(315 Hz, 0 dB)

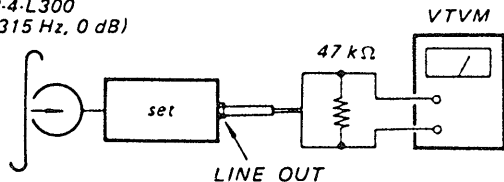

Adjust RV101 (L-CH) and RV201 (R-CH) to obtain the specified LINE OUT level.

**Adjustment Limits :**

LINE OUT level: 0.42 to 0.46 V  
(-5.3 to -4.7 dB)

Level difference between channels:  
less than 0.5 dB

Check that the LINE OUT level does not change in playback mode while changing the mode from playback to stop several times.

**3. Phase check**

- Play mode -

Reference tape for adjustment  
P-4-A100  
(10kHz, -10dB)

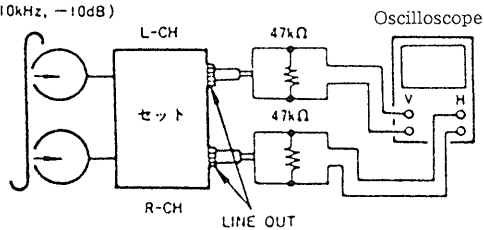

4. Check that the phase difference between L-ch and R-ch is within 0 ~ (same to 90°).

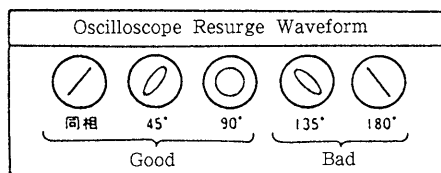

**Bias OSC Frequency Adjustment**

**Procedure :**

1. Record mode

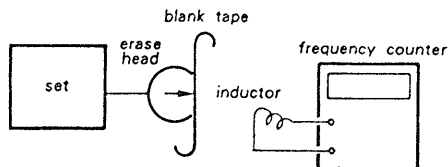

1. Connect the frequency counter to the inductor which functions at 10 mH. (When the inductor is a closed magnetic circuit, redesign the inductor to be an open magnetic circuit.)
2. Remove the cassette lid, insert the cassette, and put the unit into REC mode.
3. Move the inductor from the side in close to the erase head to check the value of the bias.
4. Adjust CP501 so that the reading on the frequency counter is 105kHz ± 1kHz.

**Bias current adjustment**

1. Set the HX PRO switch to ON and insert the METAL tape.
2. Set RV104, RV204, RV105, RV205, RV106, and RV206 to be in the center position.
3. Connect a digital voltmeter to CNE504 (between 2-1 and 2-3) and adjust the adjustment cores of T101 and T201 so that the voltage is minimized.

**CrO<sub>2</sub> Bias and Record Level Adjustment**

**Note :** This adjustment should be made before Record Bias Adjustment.

**Setting:**

REC LEVEL knob: standard record position  
(See page 12.)

HX PRO switch : ON

**Procedure:**

1. Mode: simultaneous REC/PB

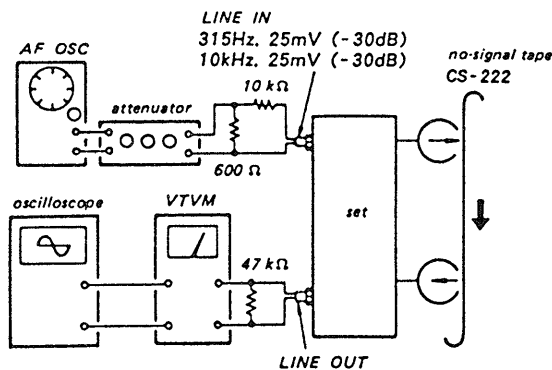

- Adjust RV106 (L-CH) and RV206 (R-CH) so that the playback output level of 10kHz signal is 0.3dB - 0.3dB with respect to that of 315Hz. . . . Record Bias Adjustment.
- Adjust RV102 (L-CH) and RV202 (R-CH) so that the playback output level of 315Hz is -25.3dB to -24.7dB. . . . Record Level Adjustment.

**Metal Bias Adjustment**

**Setting :**

REC LEVEL Knob : standard record position  
(See page 12.)

**Procedure :**

- Mode : simultaneous REC/PB

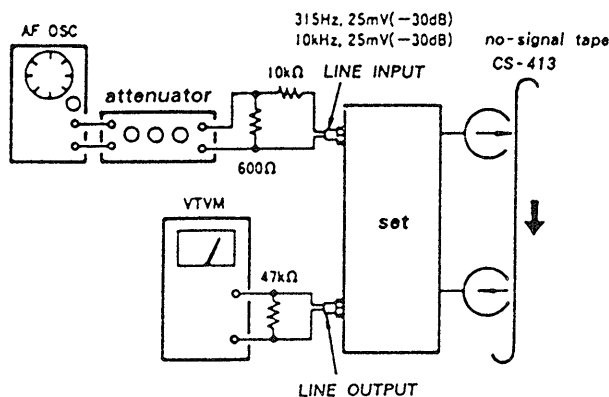

- Adjust RV510 (L-CH) and RV205 (R-CH) so that the difference between the playback output at 315Hz and that of 10kHz in R-CH is within 0.5 dB to -0.5dB.

**Normal Bias Adjustment**

**Setting:**

REC LEVEL knob: standard record position  
(See page 12.)

**Procedure:**

- Mode: simultaneous REC/PB

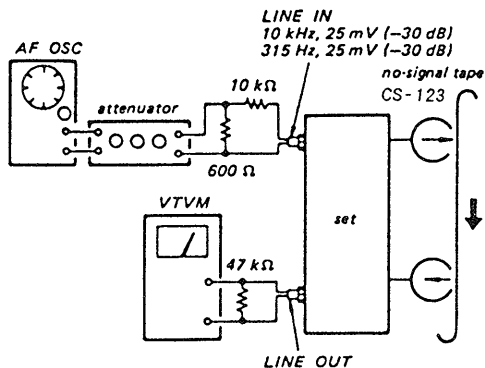

- Set the HXPRO switch to ON.
- Adjust RV103 (L-CH) and RV203 (R-CH) so that the difference between the playback output at 315Hz and that of 10kHz in R-CH is within 0.5dB to -0.5dB.
- Set the HXPRO switch to OFF.
- Adjust RV104 (L-CH) and RV204 (R-CH) so that the difference between the playback output at 10kHz when the HXPRO is ON and that of 10kHz when ON is within 0.5dB to -0.5dB.

**Meter Level Adjustment**

**Setting :**

REC LEVEL Knob : standard record position  
(See page 12.)

MONITOR : SOURCE

**Procedure :**

- Stop mode

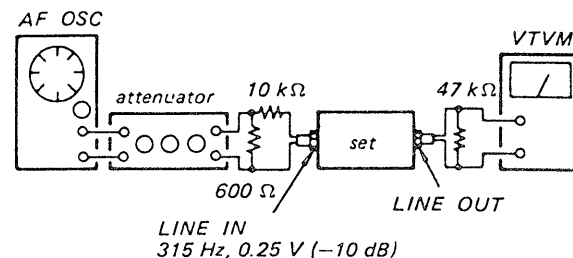

- Adjust RV107 (L-CH) and RV207 (R-CH) so that a reading of the meter is set to 0VU and the lamp is lit.
- Adjust REC level so that the LINE OUT level is set to +10dB and check that all the lamps are lit.

**Calibration OSC and Calibration Meter Adjustment**

Setting : CALBRATION switch : ON

**Procedure (OSC OUT LEVEL) :**

- Mode : record (no-signal (LINE INPUT))

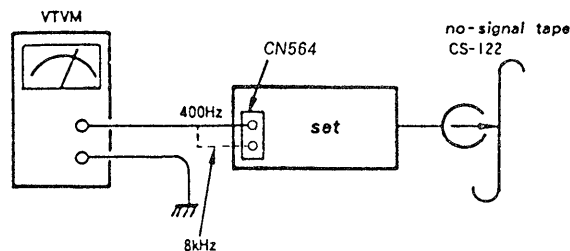

- Adjust RV504 so that a check-point level at 400Hz is +10dB.
- Adjust RV503 so that a check-point level at 8kHz is +10dB.

- Preset RV108 (LOW) so that segment (a) in LOW FREQ CAL LEVEL meter lights. Then adjust RV204 to the point where segment (a) goes out.

**Procedure (CAL METER ADJ):**

- Put the set in record mode and adjust RV208 (HIGH) so that HIGH FREQ segments in the CAL LEVEL meter light thoroughly up to 0 VU as shown in the figure below. Segment (a) may flicker.

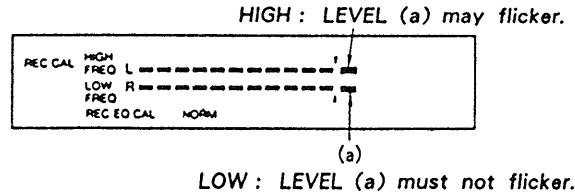

**Location Diagram of the Adjustment Parts**

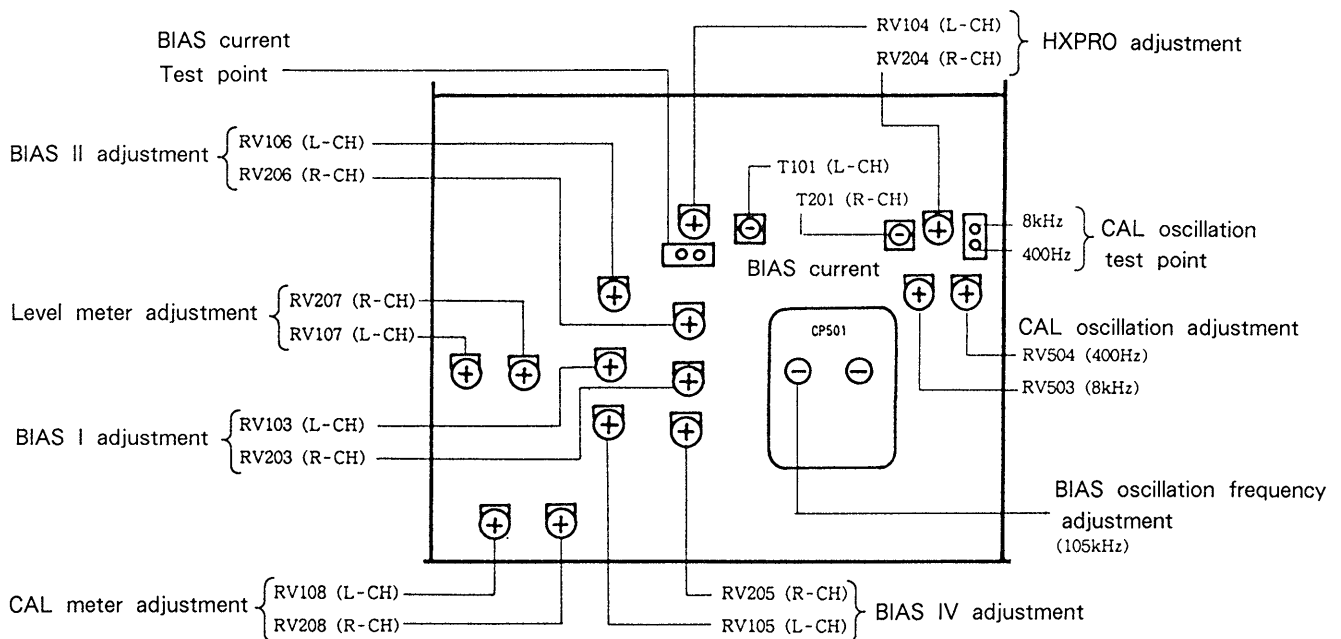
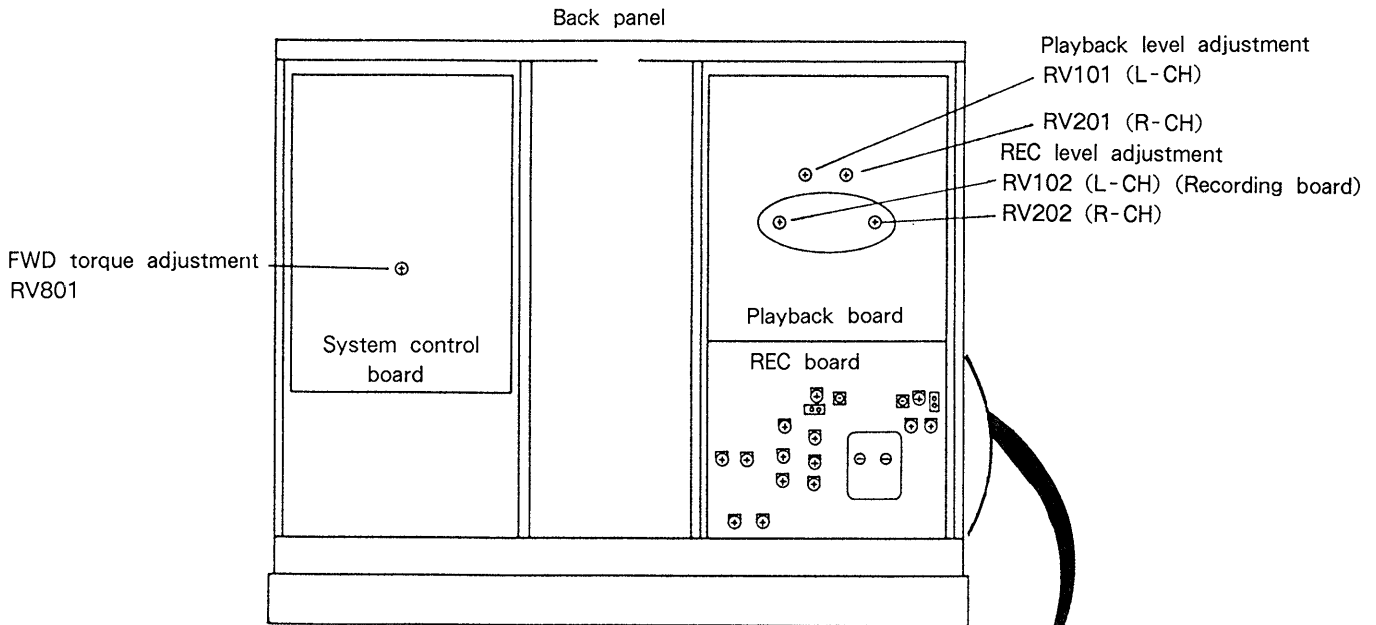



## SECTION 4 DIAGRAMS

### 4-1-1. IC502, 505 (CX20188) PIN FUNCTIONS

An electronic switch circuit for the operation mode control is included. Controls are performed by adding direct current voltages VH, VM, and VL to Dolby OFF/B/C and calibration/REC/Playback terminals.

CX20188	Pin name	Description
Pin No.		
1.	Vcc	Positive power supply terminal.
2, 41.	REC IN	Recording input terminal.
3.	I REF	Reference current input terminal.
4, 39.	PB IN	Playback input terminal.
5.	CAL/REC/PB	Calibration/recording/playback select terminal
6, 37.	PB FB	Playback feedback terminal.
7, 36.	REC FB	Recording feedback terminal.
8, 35.	GND	GND terminal.
9, 34.	LINE OUT	Line output (decode output) terminal.
10, 33.	SSK	Spectral skewing switch terminal.
11, 32.	VF IN	Encode circuit input terminal.
12, 31.	HPF H	HLS high-pass filter terminal.
13, 30.	TCH 2	HLS detector time constant terminal 2.
14, 29.	TCH 1	HLS detector time constant terminal 1.
15, 28.	WT H	HLS encoder error reduction terminal.
16, 27.	TCL 2	LLS detector time constant terminal 2.
17, 26.	TCL 1	LLS detector time constant terminal 1.
18, 25.	WT L	LLS encoder error reduction terminal.
19, 24.	HPF L	LLS high-pass filter terminal.
20, 23.	ANT S	Anti-saturation terminal.
21, 22.	REC OUT	Recording output (encode output) terminal.
38.	OFF/B/C	Dolby NR off/B type/C type select terminal.
40.	CAL IN	Calibration input terminal.
42.	Vee	Negative power supply terminal.

MODE	VOLT
VH	3 to 9.9V
VH	-0.7 to 0.7V
VL	-9.9 to -3

## 4-1-2. IC601 (M50940-313SP) PIN FUNCTIONS

Level meter display of 24-segment fluorescent display, etc., are performed by receiving direction from the master microcomputer (IC801).

Pin No.	Pin name	I/O	Description
1.	Vref	I	A/D input-port reference voltage input(+5V)
2.	$\phi$ L	I	Not used. (Connected to +5V)
3.	$\phi$ R	I	Not used. (Connected to +5V)
4.	DATA	I	Data input from the master microcomputer(IC801)(analog)
5.~6.	ADE1~ADRO	I	Data input from the master microcomputer(IC801)(analog)
7.	KEY	I	Not used. (Connected to +5V)
8.	LEVEL L	I	Level meter L-CH input(analog) from the meter amplifier(IC514)
9.	LEVEL R	I	Level meter R-CH input(analog) from the meter amplifier(IC514)
10.~13.	$\overline{\text{GRID6}}\sim\overline{\text{GRID3}}$	0	Not used.
14.~15.	$\overline{\text{GRID2}}\sim\overline{\text{GRID1}}$	0	Fluorescent display grid output
16.	$\overline{\text{CO0}}$	0	Not used.
17.	$\overline{\text{PLAY}}$	0	Not used. (Connected to pin ⑩.)
18.	$\overline{\text{PLAY}}$	0	Not used.
19.	$\overline{\text{PAUSE}}$	0	Not used.
20.	$\overline{\text{REC}}$	0	Not used.
21.	$\overline{\text{TAPE}}$	0	Fluorescent display segment output("TAPE" displayed). "L": TAPE displayed. "H": SOURCE displayed.
22.	$\overline{\text{OVER LEVEL}}$	0	Fluorescent display segment output("OVER LEVEL" displayed). It is displayed when "L".
23.	$\overline{\text{TYPE I}}$	0	Fluorescent display segment output("TYPE I" displayed). It is displayed when "L".
24.	$\overline{\text{TYPE II}}$	0	Fluorescent display segment output("TYPE II" displayed). It is displayed when "L".
25.	$\overline{\text{TYPE IV}}$	0	Fluorescent display segment output("TYPE III" displayed). It is displayed when "L".
26.	CNVss	-	Power supply terminal(GND)
27.	$\overline{\text{RESET}}$	I	Reset input
28.	XIN	I	Clock input(4MHz)
29.	XOUT	0	Clock output.
30.	XCIN	-	Not used. (Connected to GND)
31.	XCOUT	-	Not used.
32.	Vss	-	Power supply terminal(GND)
33.	$\Phi$	0	Not used.
34.	$\overline{\text{VER}}$	I	Version switching input(Always set to "L")
35.	$\overline{\text{TEST}}$	I	Test mode input. "L": All the lamps of the meter are lit.
36.	CAL	I	Calibration switch(S602) input. "L": CAL mode. "H": Normal mode.
37.	IN	I	Not used. (Connected to GND.)
38.	VP	I	Fluorescent display segment output's pull-down power supply terminal(-22V)
39.~62.	S23~S0	0	Fluorescent display segment output(meter display)
63.	AVcc	-	Power supply terminal(+5V)
64.	Vcc	-	Power supply terminal(+5V)

## 4-1-3. IC801 (M50964-220SP) PIN FUNCTIONS

Pin No.	Pin name	I/O	Description
1.	VCC		Power supply: +5V.
2.	AVss		Analog GND.
3.	Vref	I	A/D port reference voltage input.
4.	DA		Not used for this model.
5.	PWM		Not used for this model.
6.	P.OFF		Not used for this model. Connected to GND.
7.	LED	O	PAUSE LED output.
8.	LED	O	REC LED output.
9.	LED	O	PLAY LED output.
10.	AD1	I	Key input. 0V=▲, 1V=■, 2V=◀, 3V=▶, 4V=●.
11.	AD2	I	Key input. 0V=▶, 1V=■, 2V=◀, 3V=▶, 4V=○.
12.	AMS SIG	I	AMS signal input. No song detected = Low. Song detected = High.
13.	AD4	I	Key input. 2V = DISPLAY. 3V = MONITOR.
14.	CODE	I	Remote control category select switch.
15.	ALB		Connected to 5V.
16.	φR	I	Take-up reel base sensor input.
17.	φL	I	Supply reel base sensor input.
18.	C RESET		Model select input. Connected to GND.
19.	C MEMORY		Model select input. Connected to GND.
20.	COO		Not used for this model.
21.	POWER IN	I	Power on and off detection.
22.	SIRW	I	SIRCS phase input.
23.	SIRE	I	SIRCS reverse phase input.
24.	T-REC	I	Timer REC switch input.
25.	T-PLAY	I	Timer PLAY switch input.
26.	INT	I	External interruption input. Interruption process is performed when the power is on or off.
27.	Vss		GND.
28.	RESET	I	Reset input.
29.	XIN	I	Clock input (4 MHz).
30.	XOUT	O	Clock output (4 MHz).
31.	φout		Not used for this model.
32.	Vss		GND.
33.	C1	I	Rotary encoder input to detect the position of the head base of the mechanical block.
34.	C2	I	Rotary encoder input to detect the position of the head base of the mechanical block.
35.	C3	I	Rotary encoder input to detect the position of the head base of the mechanical block.
36.	C4	I	Rotary encoder input to detect the position of the head base of the mechanical block.
37.	OPEN SW	I	OPEN switch input of the mechanical block.
38.	CLOSE SW	I	CLOSE switch input of the mechanical block.
39.	DOOR SW	I	DOOR switch input of the mechanical block.
40.	REC SW	I	REC switch input of the mechanical block.
41.	M PLAY	O	Reel motor rotates at PLAY speed.
42.	M FAST	O	Reel motor rotates at FF/REW speed.
43.	M FWD	O	Reel motor rotates.
44.	M REV	O	Reel motor rotates in reverse.
45.	CAM DOWN	O	Head base DOWN output of the mechanical block
46.	CAM UP	O	Head base UP output of the mechanical block
47.	C OFF	O	Counter light-off output
48.	M OFF	O	Meter light-off output
49.	BIAS	O	Bias oscillation on and off control
50.	R Mi	O	REC MUTE.
51.	M Mi		Not used for this model.
52.	T Mi	O	Tape MUTE. Goes to low when the tape is being played.
53.	S Mi	O	Source MUTE. Goes to low three seconds after the power is on.
54.	AMS	O	AMS switch output. Goes to low when AMS is being used.
55.	MONITOR		Not used for this model. Connected to GND.
56.	HALF		Not used for this model. Connected to GND.
57.	DAT3	O	Outputs parallel data for the counter display.
58.	DAT2	O	Outputs parallel data for the counter display.
59.	DAT1	O	Outputs parallel data for the counter display.
60.	DATO	O	Outputs parallel data for the counter display.
61.	DATD	O	Outputs parallel data for the counter display.
62.	CLK	O	Clock output to transmit the parallel data.
63.	LATCH	O	Output for latching the transmitted data.
64.	CAL IN	I	CAL switch input.

**4-1-4. IC881 (HD404240A80S) PIN FUNCTIONS**

Fluorescent dynamic display is performed by receiving count data from the master microcomputer (IC801)

Pin No.	Pin name	I/O	Description
1.	SG3	0	Fluorescent display grid output
2.	G4	0	Fluorescent display grid output
3.	dot	0	Fluorescent display segment output
4.	P DWN	I	Pull-down power supply terminal for fluorescent display segment output (-22V)
5.~11.	g~a	0	Fluorescent display segment output
12.	-	-	Not used.
13.~16.	DIM1~DIM4	I	Dimmer input (Pins ⑭ and ⑯ are "H". Others are opened and fixed: Blanking time 550usec; grid ON time 450usec.)
17.~20.	-	-	Not used.
21.	Vcc	-	Power supply terminal (+5V)
22.	SCK	I	Shift clock input (250kHz) from the master microcomputer (IC801)
23.	SI	I	Serial data input (Data are sent by 1 byte every 6msec.) from the master microcomputer (IC801)
24.~25.	-	-	Not used.
26.	RESET	I	Reset input from the master microcomputer (IC801). Reset when "H".
27.	TEST	I	Connected to +5V.
28.	OSC1	I	Clock input (4MHz)
29.	OSC2	I	Clock input (4MHz)
30.	GND	-	Power supply terminal (GND)
31.~34.	-	-	Not used.
35.	MLED	0	Not used. (Connected to +5V)
36.~40.	-	-	Not used.
41.	G2	0	Fluorescent display grid output
42.	G1	0	Fluorescent display grid output

**4-2. CIRCUIT BOARDS LOCATION**

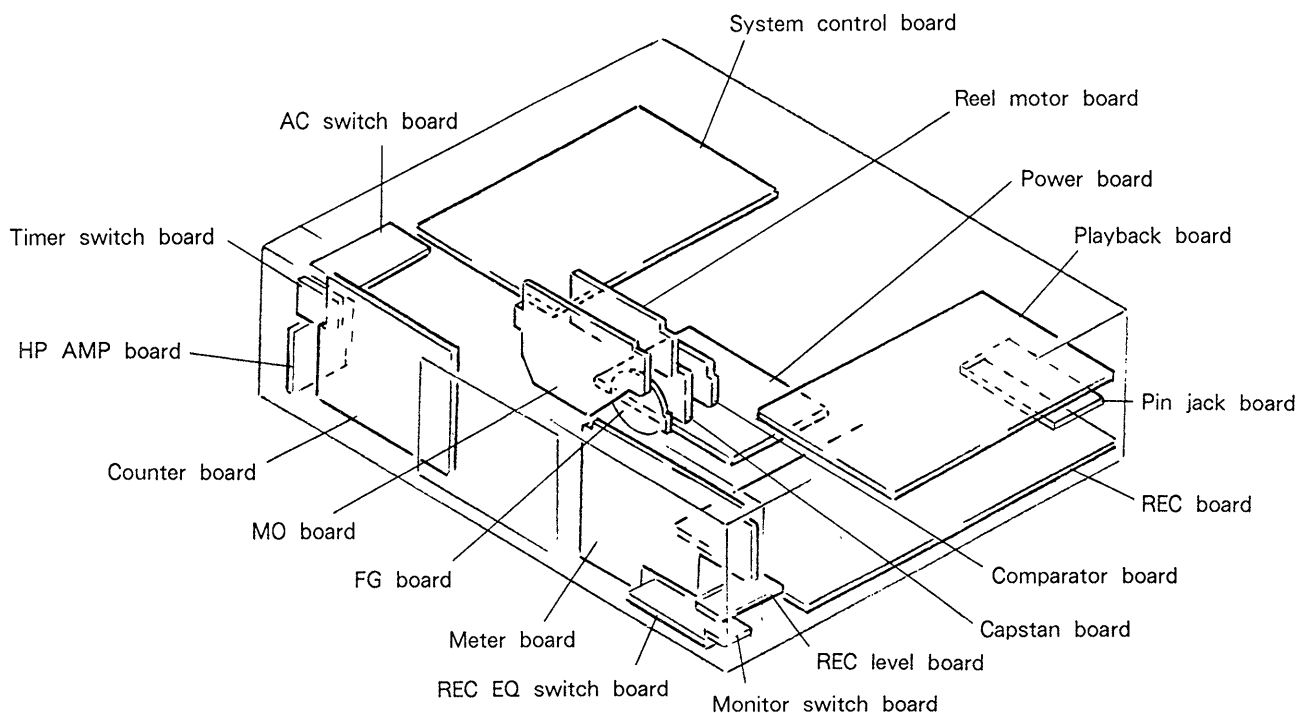

4-3. IC BLOCK DIAGRAMS

IC502, 505 CX20188

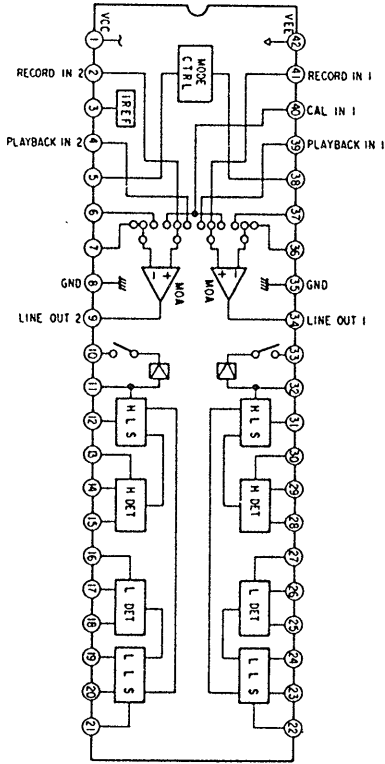

IC902 CX20174

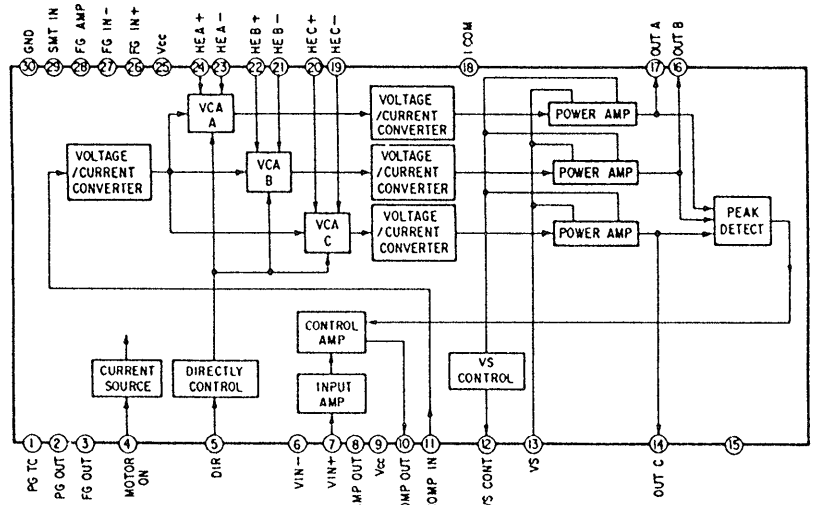

IC952 TC-9142P

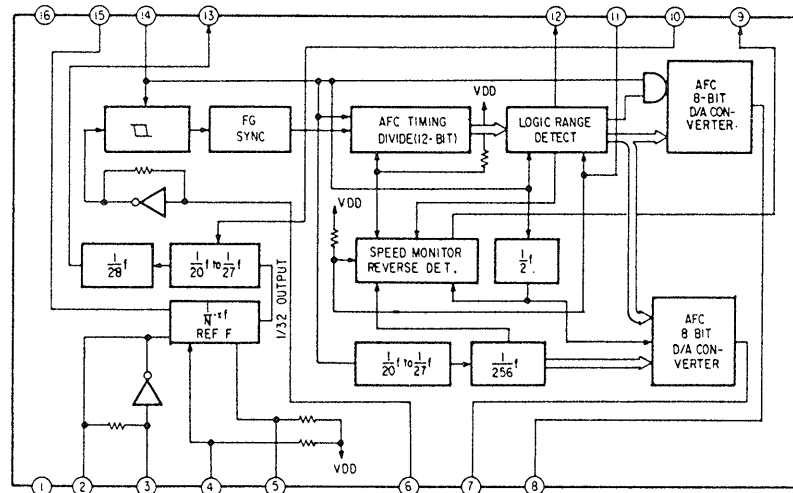

IC508  $\mu$ PC1297CA

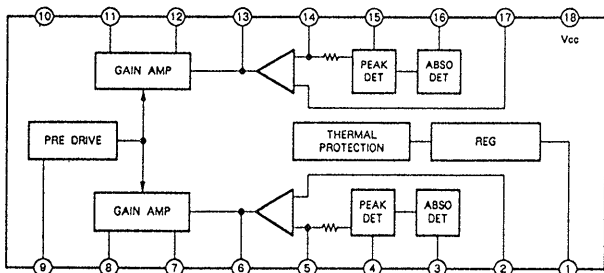

IC802 BA6219B

IC803 LB1641

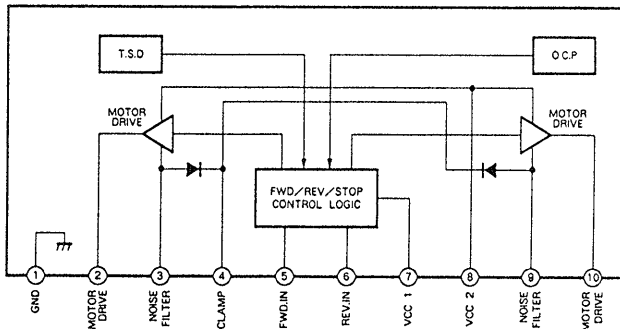

4-4. SEMICONDUCTOR LEAD LAYOUTS

BA6219B

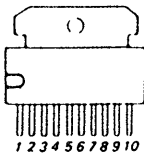

M5F7807  
RC79L12A

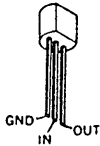

M5F7907  
RC78L12A

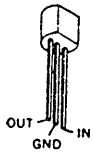

2SK246-GR2

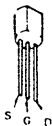

2SK147



2SB716  
2SC945-P  
2SC1815-GR  
2SD666A

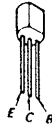

DTA114ES  
DTA144ES  
DTC114ES  
DTC124ES  
DTC143ES  
DTC144ES  
2SB1370-EF  
2SC2603-EF  
2SC2682-QPE  
2SC3623A-LK  
2SD2061-EF



2SA985A  
2SC2275A

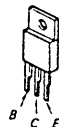

2SB734-34



2SA1175-HFE  
2SD1020-HFE

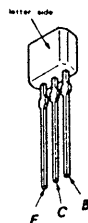

RD5.1JS-B1  
HZS6C1L  
HZS6C3L  
UZL-6M2  
UZL-24L  
1SS202-1

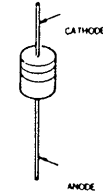

HZ6B2L  
HZ12B2L  
10E2N

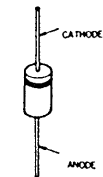

30DF2

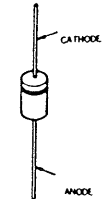

SEL4414E-C  
SEL4814A-CD

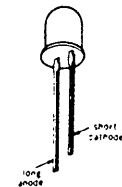

SEL4214S



4-5. BLOCK DIAGRAM

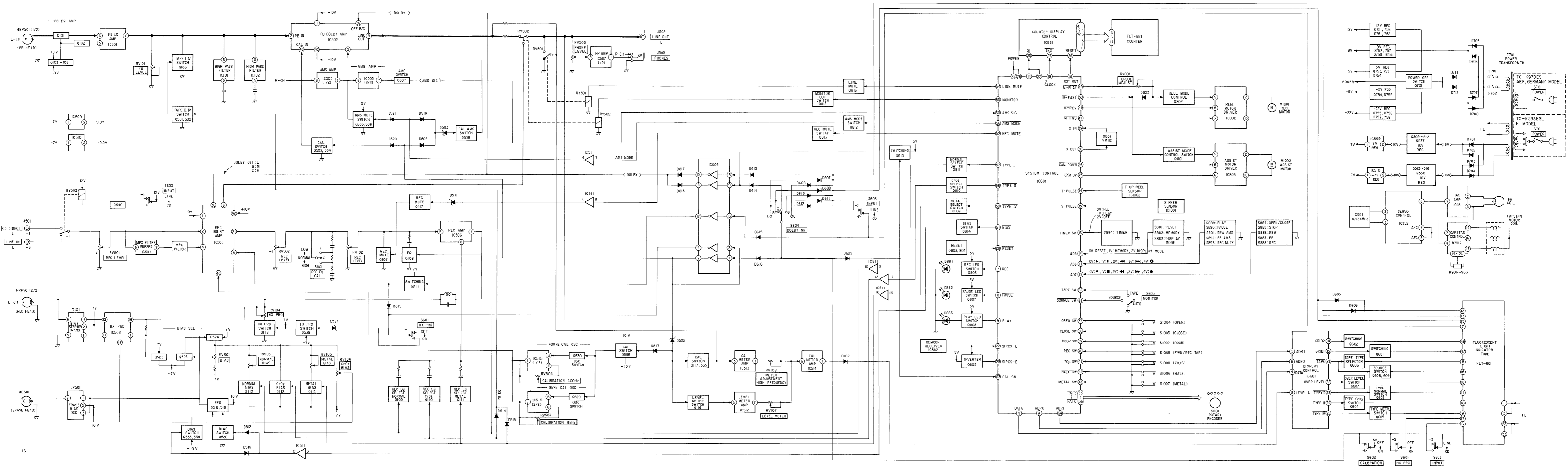

• Semiconductor Location

Ref. No.	Location	Ref. No.	Location
D101	I-16	Q105	B-10
D102	I-16	Q106	A-12
D103	I-16	Q107	I-8
D201	H-15	Q108	H-9
D202	H-15	Q109	H-9
D203	H-16	Q110	H-9
D501	E-15	Q111	H-9
D502	A-15	Q112	H-14
D503	A-15	Q113	H-13
D509	C-9	Q114	H-14
D510	C-9	Q116	G-13
D511	H-8	Q117	G-14
D512	I-15	Q118	I-11
D514	H-8	Q201	D-11
D515	H-8	Q202	D-11
D516	J-16	Q203	D-10
D517	K-15	Q204	D-10
D519	A-14	Q205	D-10
D520	A-14	Q206	E-12
D521	A-14	Q207	J-8
D522	G-6	Q208	J-9
D523	G-8	Q209	J-9
D524	I-3	Q210	J-9
D525	H-11	Q211	J-9
D526	H-13	Q212	H-14
D527	G-10	Q213	H-13
D601	D-22	Q214	H-14
D602	D-22	Q216	G-13
D603	B-19	Q217	G-14
D604	B-19	Q218	J-11
D605	C-19	Q501	A-13
D606	B-22	Q502	A-13
D607	E-23	Q503	A-13
D608	E-23	Q504	D-14
D609	E-22	Q505	E-14
D610	D-22	Q507	E-15
D612	D-22	Q508	A-15
D613	D-23	Q509	A-10
D614	C-22	Q510	B-9
D615	D-22	Q511	B-9
D616	D-23	Q512	A-9
D617	C-22	Q513	E-10
D618	C-22	Q514	D-9
D619	C-22	Q515	D-9
D620	D-20	Q516	E-9
		Q517	H-8
IC101	B-13	Q518	J-15
IC102	B-13	Q519	J-15
IC201	E-13	Q520	I-15
IC202	E-13	Q522	I-13
IC501	C-11	Q523	I-14
IC502	C-15	Q524	I-14
IC503	E-14	Q529	J-14
IC504	I-5	Q530	K-14
IC505	I-7	Q533	J-16
IC506	I-10	Q534	J-15
IC507	B-5	Q535	G-14
IC508	J-11	Q536	J-15
IC509	J-16	Q537	B-9
IC510	J-15	Q538	D-9
IC511	G-7	Q539	H-11
IC512	G-13	Q540	G-11
IC513	G-15	Q601	B-22
IC514	H-15	Q602	B-23
IC515	K-14	Q603	B-18
IC518	H-5	Q604	B-18
IC519	H-5	Q605	B-18
IC601	B-21	Q606	B-18
IC602	C-22	Q607	B-19
		Q608	B-19
Q101	B-11	Q609	B-19
Q102	B-11	Q610	B-19
Q103	B-10	Q611	B-22
Q104	B-10		

Note on Mounting Diagram:  
 ● : parts extracted from the component side.  
 ● : parts mounted on the conductor side.

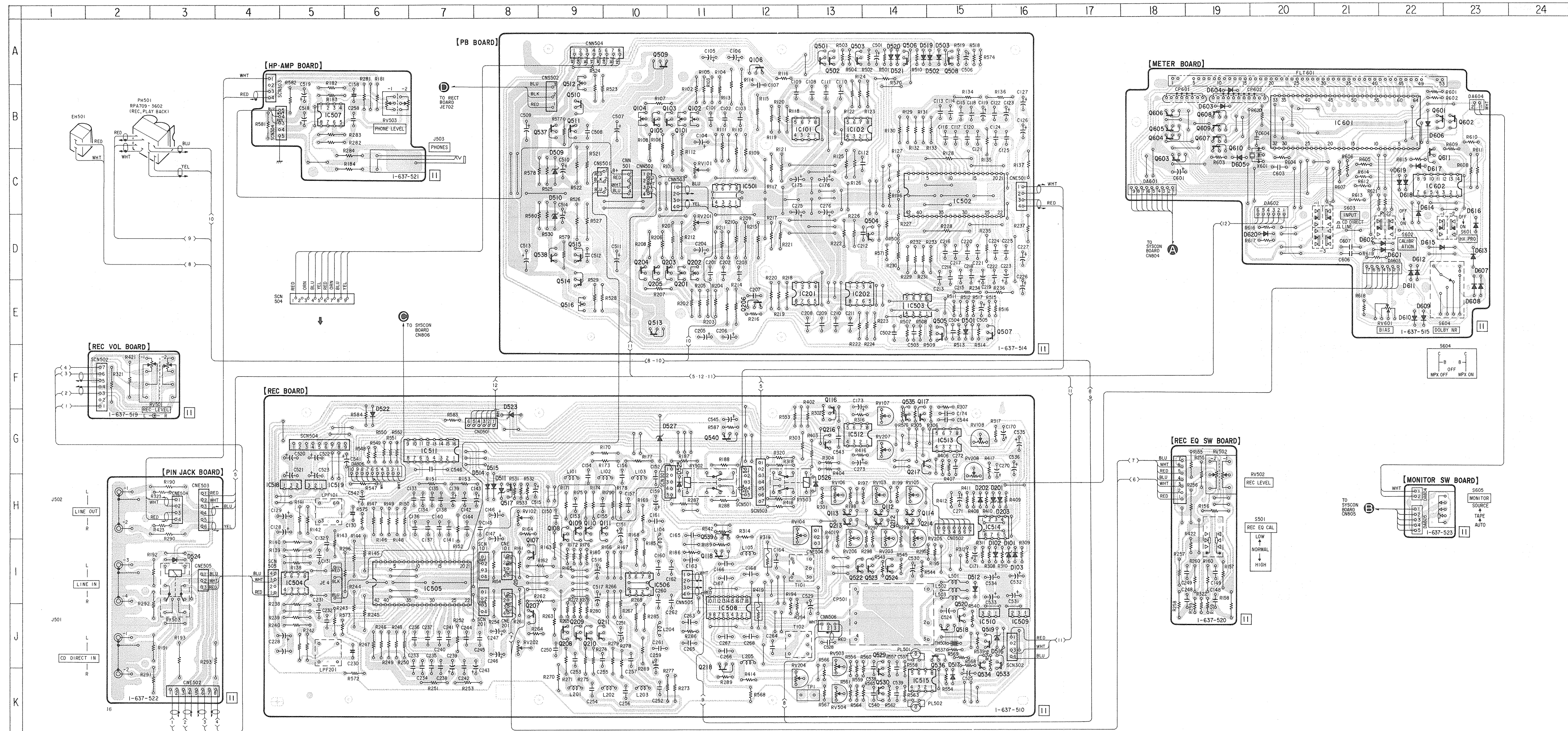



A B C D E F G H I J K L M N O

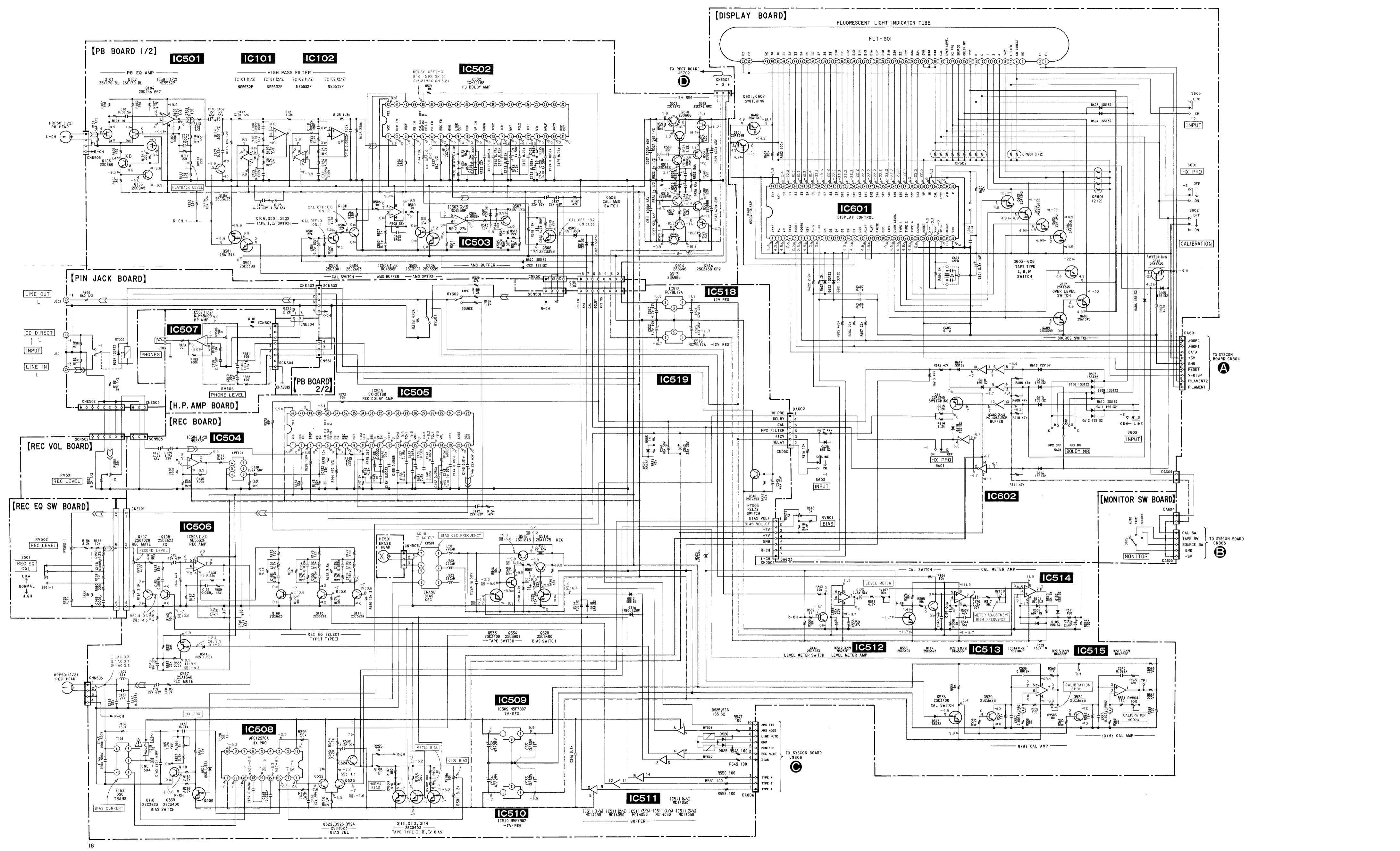

**Note on Schematic Diagram:**

- All capacitors are in  $\mu\text{F}$  unless otherwise noted. pF:  $\mu\text{pF}$  50WV or less are not indicated except for electrolytics and tantalums.
- All resistors are in  $\Omega$  and  $\frac{1}{4}W$  or less unless otherwise specified.
- Components for right channel have same values as for left channel. Reference numbers are coded from 200, 400.
- $\Delta$ : internal component.
- $\square$ : nonflammable resistor.
- $\text{---}/\text{---}$ : fusible resistor.

**Note:** The components identified by mark  $\Delta$  or dotted line with mark  $\Delta$  are critical for safety. Replace only with part number specified.

$\ominus$  : B+ Line  
 $\oplus$  : B- Line  
 $\square$  : adjustment for repair.  
 $\ominus$  : Voltage and waveforms are dc with respect to ground under no-signal (detuned) conditions.  
 no mark : STOP  
 $\triangleright$  : PLAY       $\parallel$  : PAUSE      I : NORMAL TAPE  
 $\text{---}$  : REC      II : CrO<sub>2</sub> TAPE  
 $\text{---}$  : FF  
 $\text{---}$  : METAL TAPE  
 $\text{---}$  : REV  
 $\ominus$  : Voltages are taken with a VOM (input impedance 10M  $\Omega$ )  
 Voltage variations may be noted due to normal production tolerances.  
 $\ominus$  : Signal path.  
 $\text{---}$  : PB (DECK A)  
 $\text{---}$  : REC (DECK A)

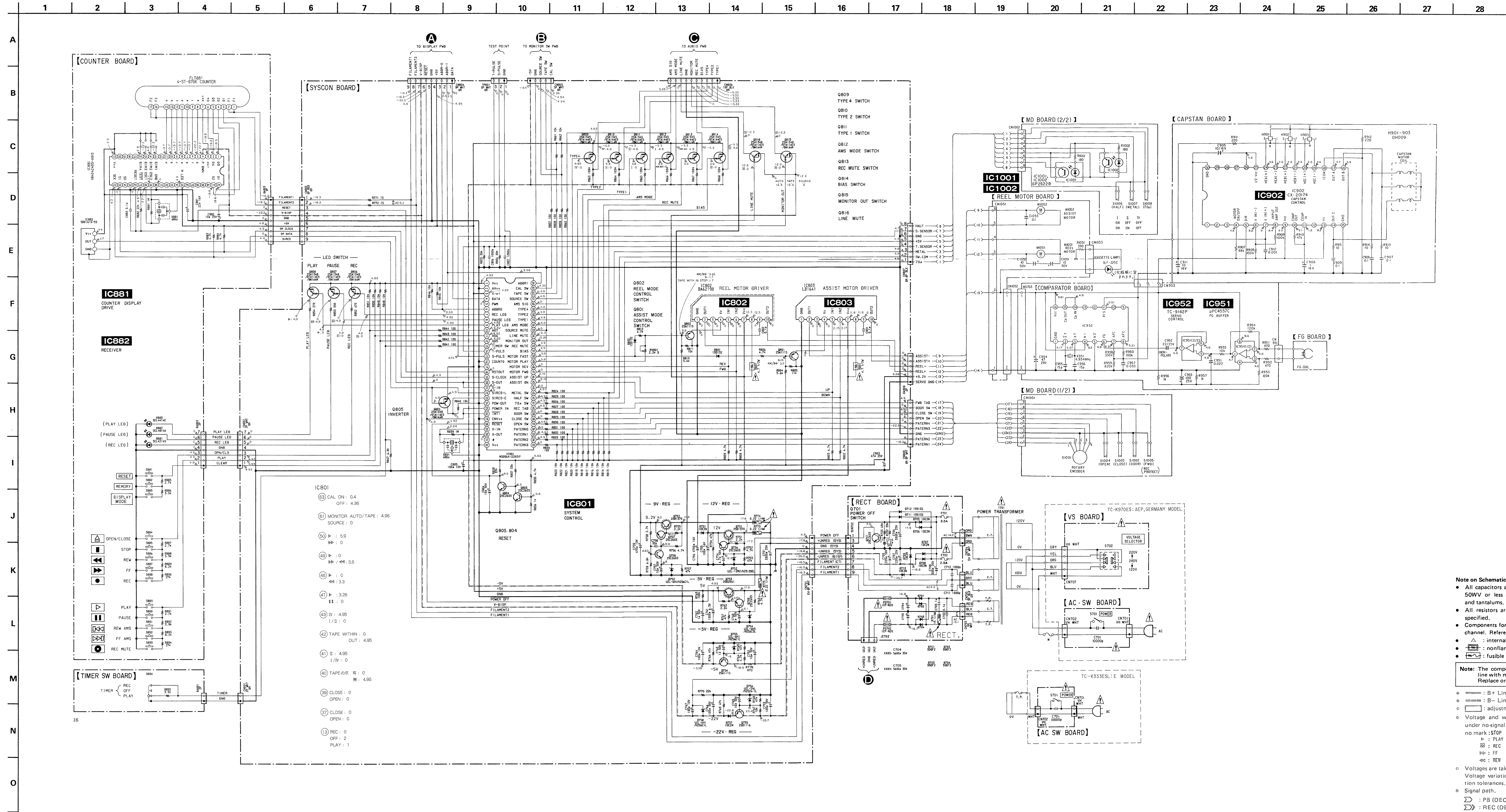

**Note on Schematic Diagram:**

- All capacitors are in  $\mu\text{F}$  unless otherwise noted.  $\text{pF}$  =  $\mu\text{F}$  50WV or less are not indicated except for electrolytics and tantalums.
- All resistors are in  $\Omega$  and  $\frac{1}{2}$ W or less unless otherwise specified.
- Components for right channel have same values as for left channel. Reference numbers are coded from 200, 400.
- $\Delta$ : internal component.
- $\square$ : nonflammable resistor.
- $\square$ : fusible resistor.

**Note:** The components identified by mark  $\Delta$  or dotted line with mark  $\Delta$  are critical for safety. Replace only with part number specified.

- $\ominus$ : B+ Line
- $\oplus$ : B- Line
- $\square$ : adjustment for repair.
- Voltage and waveforms are dc with respect to ground under no-signal (detuned) conditions.
- no mark: STOP
- $\square$ : PLAY
- $\square$ : PAUSE
- $\square$ : NORMAL TAPE
- $\square$ : REC
- $\square$ :  $\text{CrO}_2$  TAPE
- $\square$ : FF
- $\square$ : METAL TAPE
- $\square$ : REC
- Voltages are taken with a VOM (input impedance 10M $\Omega$ ). Voltage variations may be noted due to normal production tolerances.
- Signal path
- $\square$ : PB (DECK A)
- $\square$ : REC (DECK A)

4-9. PRINTED WIRING BOARDS - SYSCON SECTION -

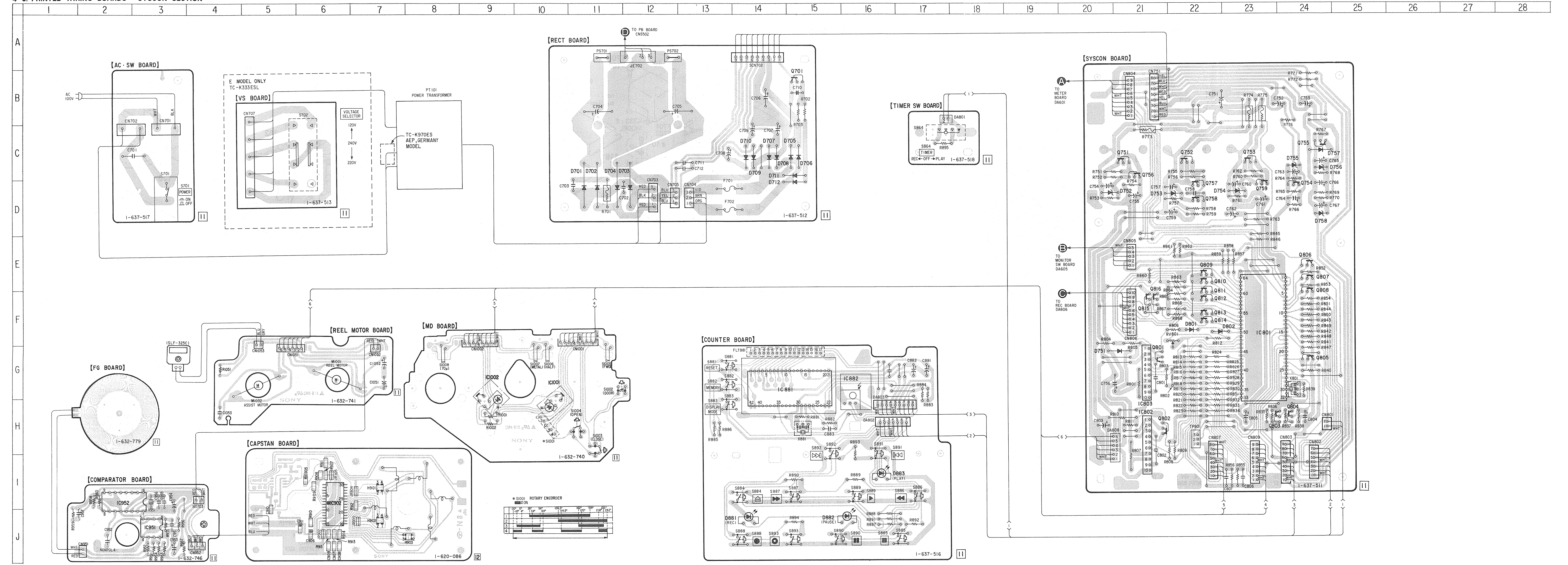

• Semiconductor Location

Ref. No.	Location
D701	D-11
D702	D-11
D703	D-12
D704	D-11
D705	C-15
D706	C-15
D707	C-14
D708	C-14
D709	C-14
D710	C-14
D711	C-15
D712	D-15
D751	G-20
D752	D-20
D753	D-22
D754	D-23
D755	C-24
D756	C-24
D757	C-24
D758	D-24
D801	F-22
D802	F-22
D881	J-14
D882	J-15
D883	I-16
IC801	F-23
IC803	H-21
IC803	G-21
IC881	G-14
IC882	G-16
IC902	I-6
IC951	J-3
IC952	I-2
IC1001	G-10
IC1002	G-9
Q701	B-15
Q751	C-21
Q752	C-22
Q753	C-23
Q754	D-24
Q755	C-24
Q756	C-21
Q757	D-22
Q758	D-22
Q801	G-23
Q802	H-21
Q803	H-23
Q804	H-24
Q805	G-24
Q806	E-24
Q807	E-24
Q808	F-24
Q809	E-22
Q810	E-22
Q811	F-22
Q812	F-22
Q813	F-22
Q814	F-22
Q815	F-21
Q816	F-21

Note on Mounting Diagram:  
 • ○ : parts extracted from the component side.

## SECTION 5 EXPLODED VIEWS

**NOTE:**

- -XX, -X mean standardized parts, so they may have some differences from the original one.
- Color Indication of Appearance Parts  
Example:  
KNOB, BALANCE (WHITE)...(RED)  
                          ↑                          ↑  
Parts color      Cabinet's color
- Items marked "\*" are not stocked since they are seldom required for routine service. Some delay should be anticipated when ordering these items.
- The mechanical parts with no reference number in the exploded views are not supplied.
- Hardware (# mark) list is given in the last of this parts list.

The components identified by mark  $\triangle$  or dotted line with mark  $\triangle$  are critical for safety. Replace only with part number specified.

**5-1. OVERALL SECTION**

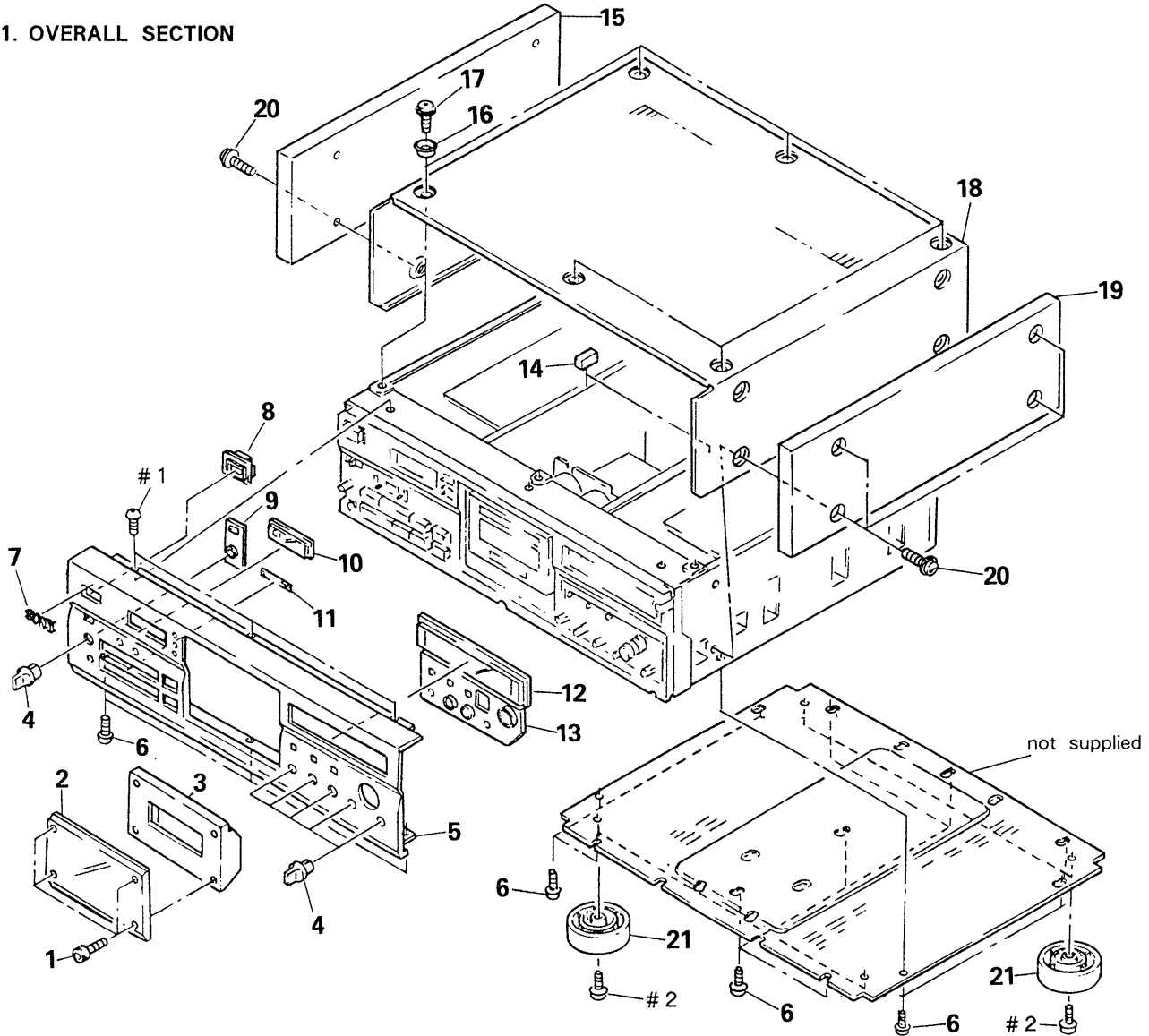

Ref. No.	Part No.	Description	Remark	Ref. No.	Part No.	Description	Remark
1	3-356-942-01	SCREW (2.6X6), TAPPING		12	3-364-443-01	WINDOW, METER	
2	3-364-438-21	WINDOW, CASSETTE		13	3-364-447-01	ESCUTCHEON (R)	
3	3-356-923-01	LID, CASSETTE		14	9-911-842-XX	CUSHION (S)	
4	X-3362-818-1	KNOB (DIA. 12) ASSY (B), SQUARE		15	X-3304-959-1	PANEL (LEFT) ASSY, SIDE	
5	3-364-475-31	PANEL, FRONT		16	4-923-474-01	RING, ORNAMENTAL	
6	3-703-685-21	SCREW (+BV 3X8)		17	3-704-366-01	SCREW (CASE) (M3X8)	
7	4-908-848-01	EMBLEM, SONY		18	* 3-350-489-11	CASE	
8	4-908-044-11	ESCUTCHEON, POWER KNOB		19	X-3304-960-1	PANEL (RIGHT) ASSY, SIDE	
9	3-364-444-01	ESCUTCHEON (L)		20	4-885-979-11	SCREW (4X25)	
10	3-364-442-11	WINDOW, COUNTER		21	X-3304-944-1	FOOT ASSY	
11	3-831-441-XX	PAPER, INTERCEPTION					

## 5-2. FRONT PANEL SECTION

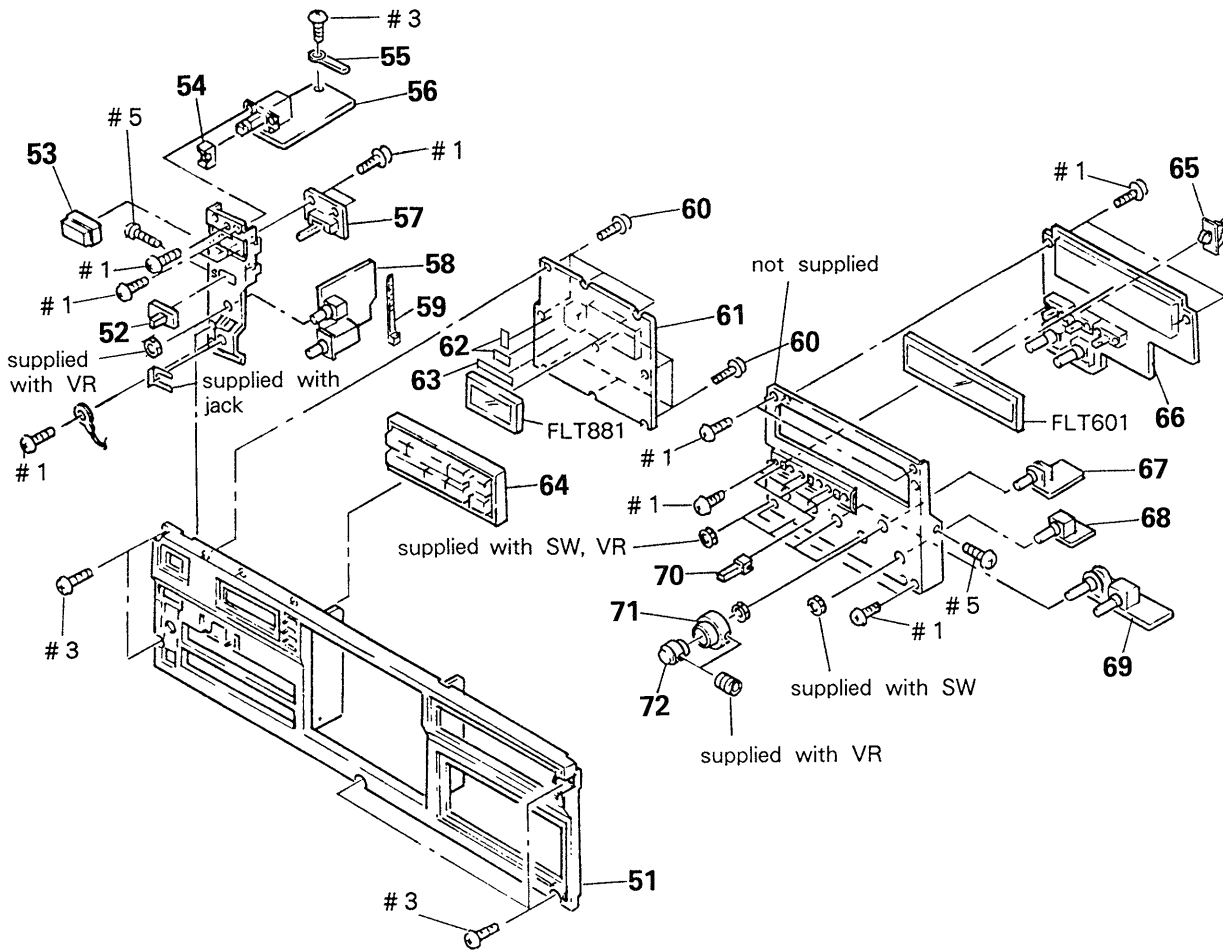

Ref. No.	Part No.	Description	Remark	Ref. No.	Part No.	Description	Remark
51	* 3-364-474-01	PANEL (BASE)		62	3-831-441-XX	SPACER	
52	4-922-518-11	KNOB (TIMER)		63	3-831-441-11	SPACER	
53	4-908-046-01	KNOB, SQUARE		64	X-3362-327-1	BUTTON ASSY	
54	4-864-307-00	RING		65	2-132-434-01	CLIP, WIRE	
55	3-703-150-11	STOPPER, WIRING		66	* A-2006-355-A	METER BOARD	
56	* 1-637-517-11	AC SW BOADR		67	* 1-637-519-11	REC VOL BOARD	
57	* 1-637-518-11	TIMER SW BOARD		68	* 1-637-523-11	MONITOR SW BOARD	
58	* 1-637-521-11	H. P. AMP BOARD		69	* 1-637-520-11	REC EQ SW BOARD	
59	3-655-653-21	BAND (TAITON), BINDING		70	3-364-441-01	BUTTON	
60	4-928-635-01	SCREW, +BV (2.6X8) TAPPING		71	3-364-440-01	KNOB (L)	
61	* 1-637-516-11	COUNTER BOARD		72	3-364-439-01	KNOB (R)	

### 5-3. CHASSIS SECTION

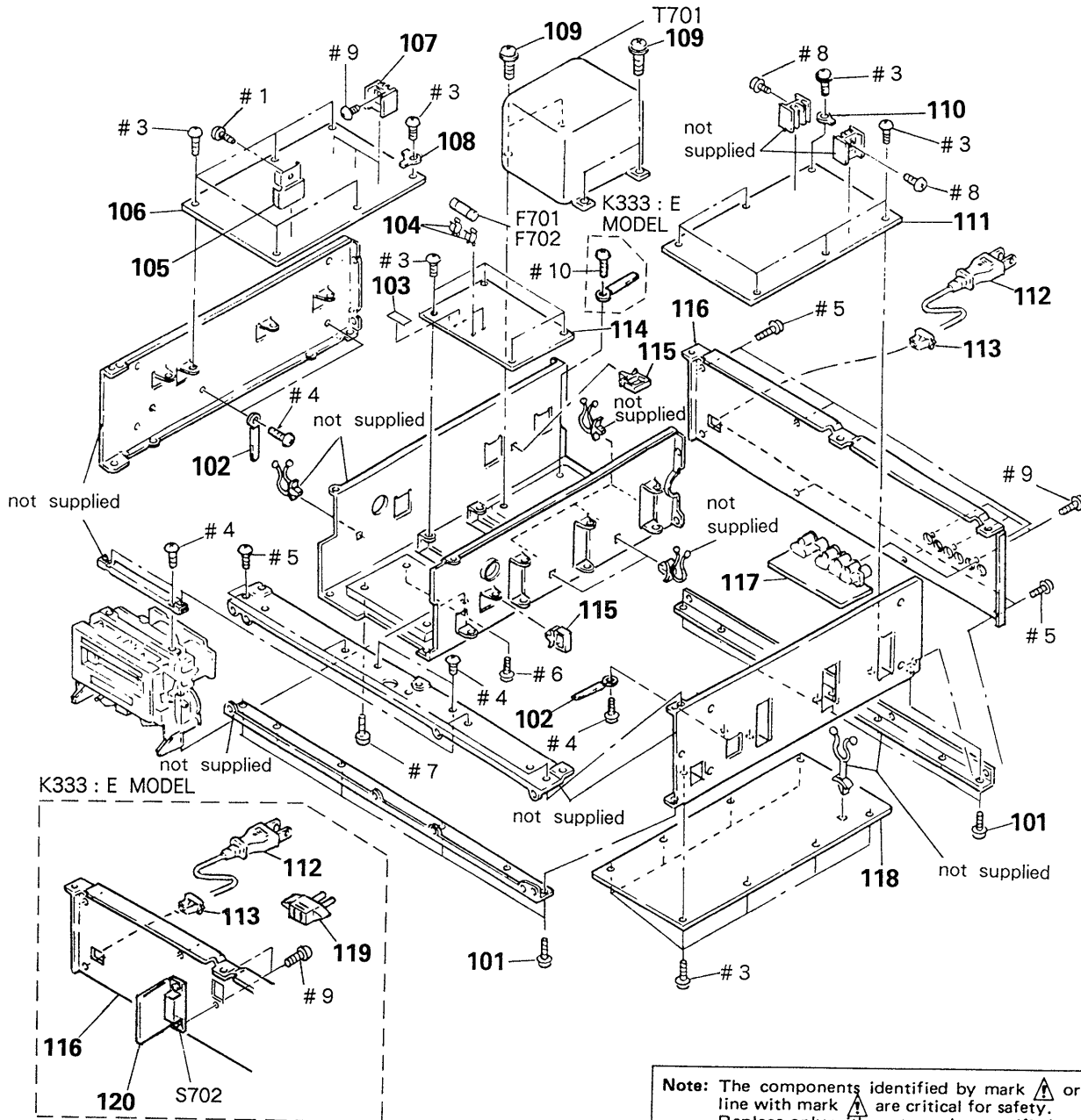

**Note:** The components identified by mark or dotted line with mark are critical for safety. Replace only with part number specified.

Ref. No.	Part No.	Description	Remark
101	3-703-685-21	SCREW (+BV 3X8)	
102	3-703-150-11	STOPPER, WIRING	
103	3-701-947-15	LABEL (T2.5A), FUSE	
104	* 1-533-213-31	HOLDER, FUSE	
105	* 3-356-925-01	HEAT SINK	
106	* A-2006-354-A	SYSCON BOARD	
107	* 4-363-146-21	HEAT SINK, V. OUT	
108	* 3-346-266-12	PLATE, GROUND	
109	4-820-330-31	SCREW (K970ES)	
	4-886-821-11	+PTTWH 3X6 (S) (K333ESL:E)	
110	3-346-266-21	PLATE, GROUND	
111	A-2006-384-A	PB BOARD	
112	1-574-383-11	CORD, POWER (K970ES)	
	1-559-297-32	CORD, POWER (K333ESL:E)	
113	* 3-703-244-00	BUSHING (2104), CORD (K970ES)	
	* 4-916-783-01	BUSHING, CORD (K333ESL:E)	

Ref. No.	Part No.	Description	Remark
114	* 1-637-512-11	RECT. BOADR	
115	* 3-329-937-02	CLIP, WIRE	
116	* 3-350-482-21	PANEL, BACK (K970ES)	
	* 3-350-482-31	PANEL, BACK (K333ESL:E)	
117	* 1-637-522-11	PIN JACK BOARD	
118	A-2006-353-A	REC BOARD	
119	1-569-007-11	ADAPTER, CONVERSION 2P (K333ESL:E)	
120	A-2006-513-3	V. S BOARD (K333ESL:E)	
F701	1-532-286-00	FUSE, TIME-LAG (2.5A)	
F702	1-532-286-00	FUSE, TIME-LAG (2.5A)	
S702	1-157-009-11	SELECTOR, VOLTAGE (K333ESL:E)	
T701	1-450-451-11	TRANSFORMER, POWER (K970ES)	
	1-450-453-11	TRANSFORMER, POWER (K333ESL:E)	

5-4. MECHANISM SECTION-1  
TCM-200D4

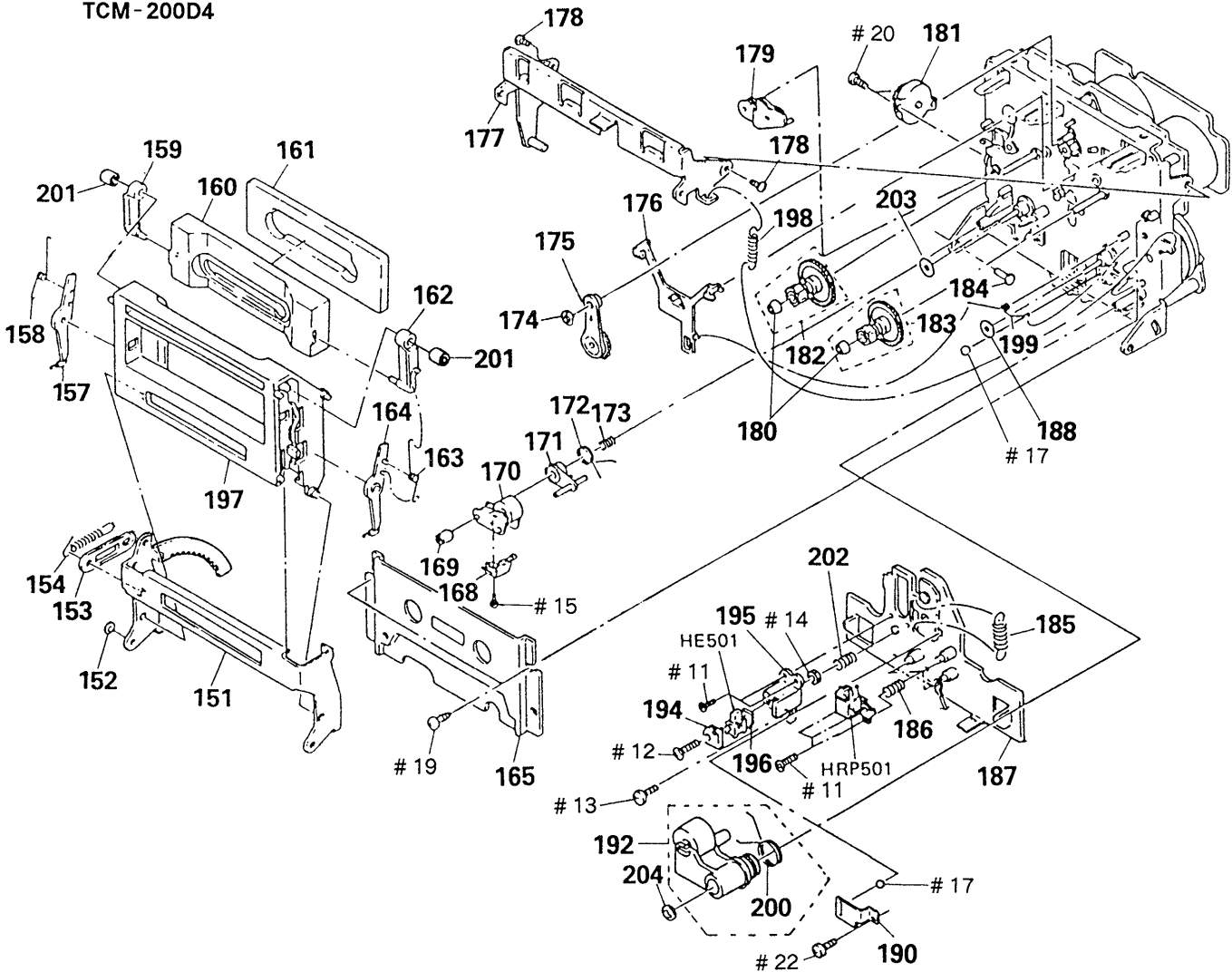

Ref. No.	Part No.	Description	Remark	Ref. No.	Part No.	Description	Remark
151	X-3362-671-1	HOLDER (BG) ASSY, CASSETTE		179	X-3356-623-1	LEVER (BT) ASSY	
152	3-558-708-21	WASHER, STOPPER		180	3-362-308-01	CAP (REEL)	
153	* 3-356-717-01	LEVER (JOINT)		181	3-319-224-31	DAMPER, SMALL	
154	3-356-626-01	SPRING, TENSION		182	X-3356-629-1	GEAR (S) ASSY	
157	3-356-932-01	LEVER (LA)		183	X-3356-627-1	GEAR (T) ASSY	
158	3-356-927-01	SPRING (LEFT), TORSION		184	3-356-710-01	SHAFT (LEFT) (CASSETTE HOLDER)	
159	3-356-933-01	LEVER (LB)		185	3-356-658-01	SPRING (LIMITER H), TENSION	
160	3-356-928-01	PLATE (A), ORNAMENTAL		187	* X-3362-199-1	SLIDER (HEAD CHASSIS D) ASSY	
161	* 3-356-929-01	ABSORBENT, VIBRATION		188	3-332-763-01	RING, OIL RESERVOIR	
162	3-356-931-01	LEVER (RB)		190	3-356-656-01	SPRING (HEAD PC BOARD), LEAF	
163	3-356-926-01	SPRING (RIGHT), TORSION		192	X-3356-620-1	LEVER (PINCH LEVER T) ASSY	
164	3-356-930-01	LEVER (RA)		194	3-318-433-01	SPRING	
165	X-3356-613-1	PLATE ASSY, ORNAMENTAL (IN CLUDED. SLF-325C		195	* 3-576-977-00	BRACKET, E. HEAD	
168	3-564-138-00	GUIDE (S), TAPE		196	* 1-608-268-00	PC BOARD, ERASE HEAD	
169	3-356-652-01	NUT (PINCH LEVER S)		197	X-3356-611-1	HOLDER (A) ASSY, CASSETTE	
170	X-3356-621-1	LEVER (PINCH LEVER S) ASSY		198	3-356-624-01	SPRING, TENSION	
171	3-356-660-01	LEVER (PS)		199	3-356-619-01	SPRING (B), TORSION	
172	3-356-661-01	SPRING (PINCH LEVER S), TORSION		200	3-356-672-01	SPRING (PINCH LEVER T), TORSION	
173	3-356-657-01	SPRING (PS), COMPRESSION		201	3-356-946-01	BUSHING	
174	3-669-465-00	WASHER (1.5), STOPPER		202	3-564-121-00	SPRING, COMPRESSION	
175	X-3356-641-1	LEVER (FR2) ASSY		203	3-356-713-01	WASHER	
176	3-356-614-01	SLIDER (BRAKE)		204	3-669-596-00	WASHER (2.3), STOPPER	
177	* X-3356-608-1	LEVER (LIFTER) ASSY		HE501	1-543-358-11	HEAD, MAGNETIC (ERASE)	
178	3-356-601-11	SCREW, STEP		HRP501	1-543-684-11	HEAD, MAGNETIC (REC/PB)	

5-5. MECHANISM SECTION-2  
TCM-200D4

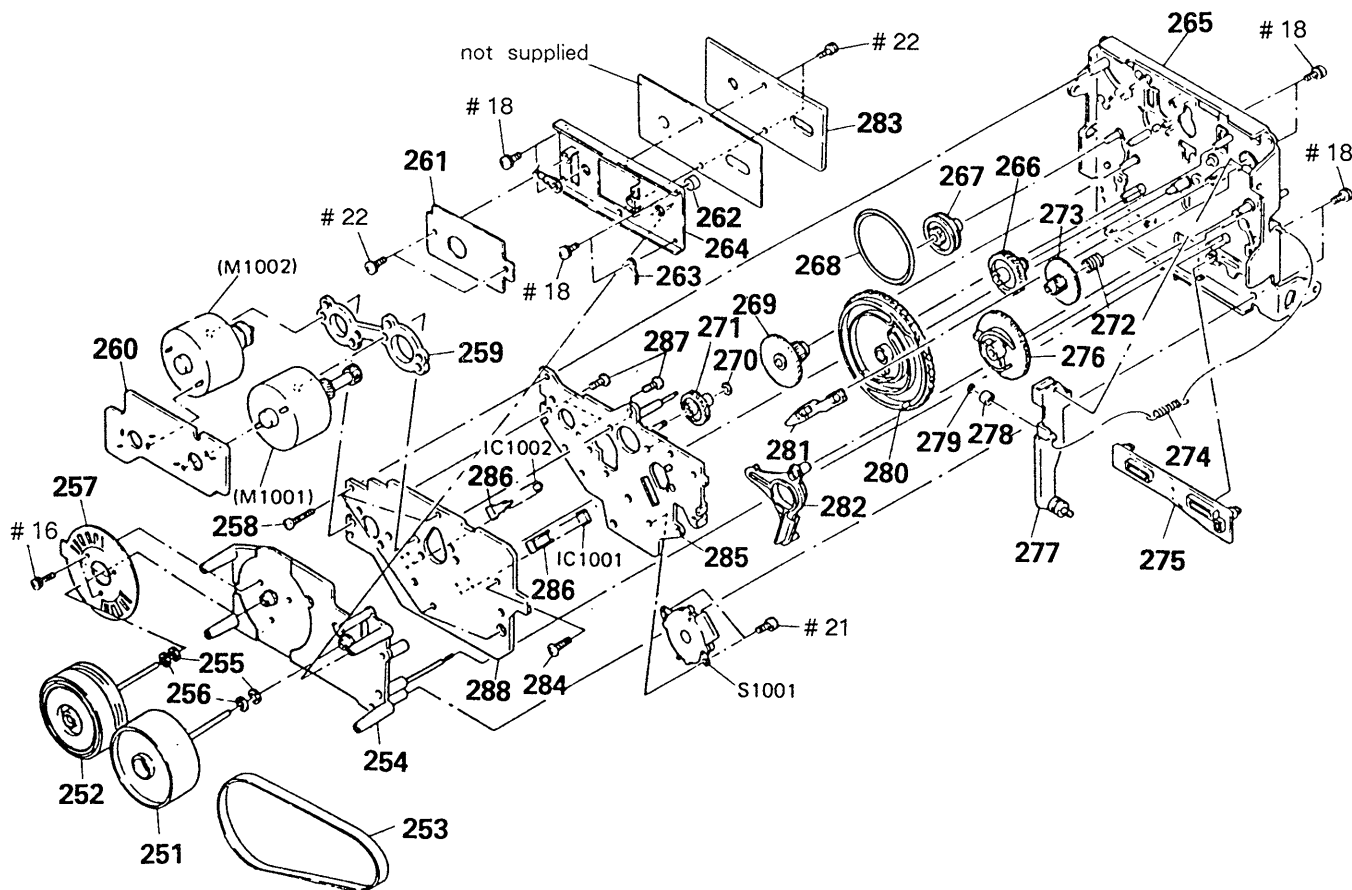

Ref. No.	Part No.	Description	Remark	Ref. No.	Part No.	Description	Remark
251	X-3362-284-1	FLYWHEEL (S2.3) ASSY		272	3-356-605-01	SPRING, COMPRESSION	
252	X-3356-619-1	FLYWHEEL (DT) ASSY		273	3-356-609-01	GEAR (LOADING)	
253	3-364-600-01	BELT (CAPSTAN)		274	3-356-625-01	SPRING, TENSION	
254	X-3362-281-1	CHASSIS (D2.3) ASSY		275	3-356-653-01	SLIDER (PAUSE)	
255	3-356-705-31	WASHER (CAPSTAN)		276	3-356-616-01	GEAR (LOADING CAM)	
256	3-356-705-21	WASHER (CAPSTAN)		277	* X-3356-606-1	LEVER (LOADING) ASSY	
257	1-632-779-11	PC BOARD, FG		278	3-356-630-01	ROLLER (LOADING)	
258	3-355-801-01	SCREW (BTP 2X18)		279	3-558-708-11	WASHER, STOPPER	
259	* 3-356-628-01	SPACER (MOTOR)		280	3-356-654-01	GEAR (MODE CAM C)	
260	* 1-632-741-11	REEL MOTOR BOARD		281	3-356-617-01	LEVER (SELECTION)	
261	* 1-632-746-11	COMPARATOR BOARD		282	3-356-613-01	LEVER (MODE)	
262	3-364-135-01	RETAINER (S), THRUST		283	A-2006-154-A	CAPSTAN C. O. C BOARD	
263	* 3-701-822-00	HOLDER, WIRE		284	3-356-707-01	SCREW (+PTPWH 2X25)	
264	* X-3362-282-1	BRACKET (THRUST RETAINER) ASSY		285	* X-3356-616-4	BRACKET (MOTOR D) ASSY	
265	X-3356-622-1	CHASSIS (C) ASSY, MECHANICAL		286	3-356-631-01	HOLDER (SENSOR)	
266	3-356-703-01	GEAR (COMMUNICATION C)		287	3-363-804-01	SCREW (+P 2.6X6.5)	
267	3-356-607-01	PULLEY (MODE)		288	* 1-632-740-11	MD BOARD	
268	3-356-603-01	BELT (MODE)		IC1001	1-506-615-11	PIN, CONNECTOR 9P	
269	3-356-606-01	GEAR (MODE)		IC1002	1-564-501-11	PIN, CONNECTOR 8P	
270	3-669-465-00	WASHER (1.5), STOPPER		M1001	X-3356-638-1	MOTOR (REEL R) ASSY	
271	3-356-702-01	GEAR (COMMUNICATION B)		M1002	X-3356-604-1	MOTOR (ASSIST) ASSY	
				S1001	1-466-238-11	ENCODER, ROTARY	



**CAPSTAN C.O.C**

**COMPARATOR MD**

**SECTION 6**

**ELECTRICAL PARTS LIST**

**NOTE :**

The components identified by mark  $\Delta$  or dotted line with mark  $\Delta$  are critical for safety. Replace only with part number specified.

When indicating parts by reference number, please include the board name.

- Due to standardization, replacements in the parts list may be different from the parts specified in the diagrams or the components used on the set.
- - XX, - X mean standardized parts, so they may have some difference from the original one.
- RESISTORS  
All resistors are in ohms.  
METAL : metal-film resistor  
METAL OXIDE : Metal Oxide-film resistor  
F : nonflammable
- Items marked "\*" are not stocked since they are seldom required for routine service. Some delay should be anticipated when ordering these items.
- SEMICONDUCTORS  
In each case, u :  $\mu$ , for example :  
uA... :  $\mu$ A... , uPA... ,  $\mu$ PA... ,  
uPB... ,  $\mu$ PB... , uPC... ,  $\mu$ PC... ,  
uPD... ,  $\mu$ PD...
- CAPACITORS :  
uF :  $\mu$ F
- COILS  
uH :  $\mu$ H

Ref. No.	Part No.	Description	Remark	Ref. No.	Part No.	Description	Remark
	A-2006-154-A	CAPSTAN C. O. C BOARD *****				< IC >	
		< CAPACITOR >					
C905	1-124-779-00	ELECT CHIP 10uF 20% 16v					
C906	1-135-091-00	TANTALUM CHIP 1uF 20% 16V					
C907	1-163-077-00	CERAMIC CHIP 0.1uF 10% 25V					
C908	1-163-077-00	CERAMIC CHIP 0.1uF 10% 25V					
C909	1-163-077-00	CERAMIC CHIP 0.1uF 10% 25V					
C910	1-163-205-00	CERAMIC CHIP 0.001uF 5% 50V					
C911	1-124-779-00	ELECT CHIP 10uF 20% 16v					
		< IC >					
H901	8-719-403-79	OH009-TW					
H902	8-719-403-79	OH009-TW					
H903	8-719-403-79	OH009-TW					
IC902	8-752-017-40	IC CX20174					
		< RESISTOR >					
R907	1-216-242-00	METAL GLAZE 68K 5% 1/8W					
R908	1-216-246-00	METAL GLAZE 100K 5% 1/8W					
R909	1-216-246-00	METAL GLAZE 100K 5% 1/8W					
R910	1-216-238-00	METAL GLAZE 47K 5% 1/8W					
R911	1-216-182-00	METAL GLAZE 220 5% 1/8W					
R912	1-216-182-00	METAL GLAZE 220 5% 1/8W					
R913	1-216-150-00	METAL GLAZE 10 5% 1/8W					
R914	1-216-150-00	METAL GLAZE 10 5% 1/8W					
R915	1-216-150-00	METAL GLAZE 10 5% 1/8W					
*****							
	* 1-632-746-11	COMPARATOR BOARD *****					
		< CAPACITOR >					
C951	1-136-157-00	FILM 0.022uF 5% 50V					
C952	1-124-282-00	ELECT 22uF 20% 25V					
C953	1-124-478-11	ELECT 100uF 20% 25V					
C954	1-124-477-11	ELECT 47uF 20% 25V					
C955	1-162-203-31	CERAMIC 15PF 5% 50V					
C956	1-162-203-31	CERAMIC 15PF 5% 50V					
C957	1-136-159-00	FILM 0.033uF 5% 50V					
		< CONNECTOR >					
CN951	* 1-564-718-11	PIN, CONNECTOR (SMALL TYPE) 2P					
CN952	* 1-564-518-11	PLUG, CONNECTOR 3P					
		< IC >					
IC951	8-759-945-58	IC RC4558P					
IC952	8-759-201-58	IC TC9142P					
		< RESISTOR >					
R951	1-249-413-11	CARBON 470 5% 1/4W					
R952	1-249-413-11	CARBON 470 5% 1/4W					
R953	1-247-881-00	CARBON 120K 5% 1/4W					
R954	1-247-881-00	CARBON 120K 5% 1/4W					
R955	1-249-429-11	CARBON 10K 5% 1/4W					
R956	1-249-417-11	CARBON 1K 5% 1/4W					
R957	1-249-417-11	CARBON 1K 5% 1/4W					
R958	1-247-891-00	CARBON 330K 5% 1/4W					
R959	1-247-901-11	CARBON 820K 5% 1/4W					
R960	1-249-441-11	CARBON 100K 5% 1/4W					
		< VIBRATOR >					
X951	1-577-615-11	VIBRATOR, CRYSTAL (4.934MHZ)					
*****							
	* 1-632-740-11	MD BOARD *****					
	3-356-631-01	HOLDER (SENSOR)					
		< CONNECTOR >					
CN1001	1-506-615-11	PIN, CONNECTOR 9P					
CN1002	1-564-501-11	PIN, CONNECTOR 8P					
		< IC >					
IC1001	8-749-920-97	IC PHOTO REFLECTOR GP2S22B					
IC1002	8-749-920-97	IC PHOTO REFLECTOR GP2S22B					
		< RESISTOR >					
R1001	1-249-408-11	CARBON 180 5% 1/4W					
R1002	1-249-408-11	CARBON 180 5% 1/4W					
		< SWITCH >					
S1002	1-570-953-11	SWITCH, PUSH (1 KEY) (DOOR)					
S1003	1-571-958-11	SWITCH, PUSH (1 KEY) (CLOSE)					
S1004	1-572-126-11	SWITCH, PUSH (1 KEY) (OPEN)					
S1005	1-572-125-11	SWITCH, LEAF (FWD)					
S1006	1-572-202-11	SWITCH, LEAF (HALF)					
S1007	1-572-125-11	SWITCH, LEAF (METAL)					
S1008	1-572-125-11	SWITCH, LEAF (70U)					

**MD REAL MOTOR PB COUNTER AC SW TIMER SW**

**REC VOL REC EQ SW H.P. AMP PIN JACK MONITOR SW**

Ref. No.	Part No.	Description	Remark	Ref. No.	Part No.	Description	Remark
		< PIN >		C107	1-136-169-00	FILM	0.22uF 5% 50V
TB1001	* 1-569-066-11	PIN, CONNECTOR 5P		C108	1-136-230-00	FILM	0.0022uF 5% 100V
		*****		C109	1-136-230-00	FILM	0.0022uF 5% 100V
				C110	1-136-230-00	FILM	0.0022uF 5% 100V
				C111	1-136-230-00	FILM	0.0022uF 5% 100V
	* 1-632-741-11	REAL MOTOR BOARD		C112	1-136-230-00	FILM	0.0022uF 5% 100V
		*****		C113	1-130-475-00	MYLAR	0.0022uF 5% 50V
		< CAPACITOR >		C114	1-130-475-00	MYLAR	0.0022uF 5% 50V
C1051	1-124-907-11	ELECT	10uF 20% 50V	C115	1-130-478-00	MYLAR	0.0039uF 5% 50V
C1052	1-124-907-11	ELECT	10uF 20% 50V	C116	1-136-173-00	FILM	0.47uF 5% 50V
C1053	1-164-159-11	CERAMIC	0.1uF 50V	C117	1-136-167-00	FILM	0.15uF 5% 50V
		< CONNECTOR >		C118	1-136-155-00	FILM	0.015uF 5% 50V
CN1051	* 1-564-499-11	PIN, CONNECTOR 6P		C119	1-123-380-00	ELECT	1uF 20% 50V
CN1052	* 1-564-718-11	PIN, CONNECTOR (SMALL TYPE) 2P		C120	1-136-169-00	FILM	0.22uF 5% 50V
CN1053	* 1-564-718-11	PIN, CONNECTOR (SMALL TYPE) 2P		C121	1-136-163-00	FILM	0.068uF 5% 50V
		< RESISTOR >		C122	1-136-162-00	FILM	0.056uF 5% 50V
R1051	1-249-412-11	CARBON	390 5% 1/4W	C123	1-123-380-00	ELECT	1uF 20% 50V
		*****		C124	1-130-480-00	MYLAR	0.0056uF 5% 50V
	* A-2006-364-A	PB BOARD		C125	1-136-153-00	FILM	0.01uF 5% 50V
		*****		C126	1-124-929-11	ELECT	22uF 20% 100V
	* 1-637-516-11	COUNTER BOARD		C127	1-124-929-11	ELECT	22uF 20% 100V
		*****		C148	1-106-347-00	MYLAR	1500PF 5% 200V
	* 1-637-517-11	AC SW BOARD		C149	1-106-343-00	MYLAR	1000PF 5% 200V
		*****		C158	1-124-767-00	ELECT	2.2uF 20% 50V
	* 1-637-518-11	TIMER SW BOARD		C175	1-123-369-00	ELECT	4.7uF 20% 63V
		*****		C176	1-123-369-00	ELECT	4.7uF 20% 63V
	* 1-637-519-11	REC VOL BOARD		C201	1-136-252-00	FILM	0.0015uF 5% 100V
		*****		C202	1-107-169-00	MICA	100PF 5% 500V
	* 1-637-520-11	REC EQ SW BOARD		C203	1-130-893-00	FILM	0.027uF 3% 100V
		*****		C204	1-124-130-00	ELECT	100uF 20% 63V
	* 1-637-521-11	H. P. AMP BOARD		C205	1-124-929-11	ELECT	22uF 20% 100V
		*****		C206	1-124-929-11	ELECT	22uF 20% 100V
	* 1-637-522-11	PIN JACK BOARD		C207	1-136-169-00	FILM	0.22uF 5% 50V
		*****		C208	1-136-230-00	FILM	0.0022uF 5% 100V
	* 1-637-523-11	MONITOR SW BOARD		C209	1-136-230-00	FILM	0.0022uF 5% 100V
		*****		C210	1-136-230-00	FILM	0.0022uF 5% 100V
	7-682-147-15	SCREW, TR		C211	1-136-230-00	FILM	0.0022uF 5% 100V
* 3-346-266-21		PLATE, GROUND		C212	1-136-230-00	FILM	0.0022uF 5% 100V
		< CAPACITOR >		C213	1-130-475-00	MYLAR	0.0022uF 5% 50V
C101	1-136-252-00	FILM	0.0015uF 5% 100V	C214	1-130-475-00	MYLAR	0.0022uF 5% 50V
C102	1-107-169-00	MICA	100PF 5% 500V	C215	1-130-478-00	MYLAR	0.0039uF 5% 50V
C103	1-130-893-00	FILM	0.027uF 3% 100V	C216	1-136-173-00	FILM	0.47uF 5% 50V
C104	1-124-130-00	ELECT	100uF 20% 63V	C217	1-136-167-00	FILM	0.15uF 5% 50V
C105	1-124-929-11	ELECT	22uF 20% 100V	C218	1-136-155-00	FILM	0.015uF 5% 50V
C106	1-124-929-11	ELECT	22uF 20% 100V	C219	1-123-380-00	ELECT	1uF 20% 50V
				C220	1-136-169-00	FILM	0.22uF 5% 50V
				C221	1-136-163-00	FILM	0.068uF 5% 50V
				C222	1-136-162-00	FILM	0.056uF 5% 50V
				C223	1-123-380-00	ELECT	1uF 20% 50V
				C224	1-130-480-00	MYLAR	0.0056uF 5% 50V
				C225	1-136-153-00	FILM	0.01uF 5% 50V
				C226	1-124-929-11	ELECT	22uF 20% 100V
				C227	1-124-929-11	ELECT	22uF 20% 100V
				C248	1-106-347-00	MYLAR	1500PF 5% 200V
				C249	1-106-343-00	MYLAR	1000PF 5% 200V
				C258	1-124-767-00	ELECT	2.2uF 20% 50V
				C275	1-123-369-00	ELECT	4.7uF 20% 63V
				C276	1-123-369-00	ELECT	4.7uF 20% 63V
				C501	1-124-927-11	ELECT	4.7uF 20% 100V

**PB COUNTER AC SW TIMER SW REC VOL REC EQ SW**

**H.P. AMP PIN JACK MONITOR SW**

Ref. No.	Part No.	Description	Remark	Ref. No.	Part No.	Description	Remark
C502	1-136-165-00	FILM	0.1uF 5% 50V	D605	8-719-107-94	DIODE 1SS202-1	
C503	1-162-284-31	CERAMIC	150PF 10% 50V	D606	8-719-107-94	DIODE 1SS202-1	
C504	1-130-478-00	MYLAR	0.0039uF 5% 50V	D607	8-719-107-94	DIODE 1SS202-1	
C505	1-124-902-00	ELECT	0.47uF 20% 50V	D608	8-719-107-94	DIODE 1SS202-1	
C506	1-124-927-11	ELECT	4.7uF 20% 100V	D609	8-719-107-94	DIODE 1SS202-1	
C507	1-124-922-11	ELECT	1000uF 20% 63V	D610	8-719-107-94	DIODE 1SS202-1	
C508	1-107-159-00	MICA	33PF 5% 500V	D611	8-719-107-94	DIODE 1SS202-1	
C509	1-126-066-11	ELECT	470uF 20% 63V	D612	8-719-107-94	DIODE 1SS202-1	
C510	1-124-122-11	ELECT	100uF 20% 50V	D613	8-719-107-94	DIODE 1SS202-1	
C511	1-124-922-11	ELECT	1000uF 20% 63V	D614	8-719-107-94	DIODE 1SS202-1	
C512	1-107-159-00	MICA	33PF 5% 500V	D615	8-719-107-94	DIODE 1SS202-1	
C513	1-126-066-11	ELECT	470uF 20% 63V	D616	8-719-107-94	DIODE 1SS202-1	
C514	1-124-122-11	ELECT	100uF 20% 50V	D617	8-719-107-94	DIODE 1SS202-1	
C518	1-124-122-11	ELECT	100uF 20% 50V	D618	8-719-107-94	DIODE 1SS202-1	
C519	1-124-122-11	ELECT	100uF 20% 50V	D619	8-719-107-94	DIODE 1SS202-1	
C601	1-131-368-00	TANTALUM	3.3uF 10% 16V	D620	8-719-107-94	DIODE 1SS202-1	
C603	1-164-159-11	CERAMIC	0.1uF 50V	D881	8-719-304-32	DIODE SEL4214S-C	
C604	1-164-159-11	CERAMIC	0.1uF 50V	D882	8-719-312-65	DIODE SEL4814A-CD	
C606	1-164-159-11	CERAMIC	0.1uF 50V	D883	8-719-304-37	DIODE SEL4414E-C	
C607	1-164-159-11	CERAMIC	0.1uF 50V			( FLUORESCENT INDICATOR )	
C701	1-161-744-00	CERAMIC	0.01uF 400V	FLT601	1-519-629-11	INDICATOR TUBE, FLUORESCENT	
C881	1-124-234-00	ELECT	22uF 20% 16V	FLT881	1-519-630-11	INDICATOR TUBE, FLUORESCENT	
C882	1-126-096-11	ELECT	10uF 20% 35V			( IC )	
C883	1-164-159-11	CERAMIC	0.1uF 50V	IC101	8-759-900-72	IC NE5532P	
		( CONNECTOR )		IC102	8-759-900-72	IC NE5532P	
CN598	* 1-560-061-00	PIN, CONNECTOR 3P		IC201	8-759-900-72	IC NE5532P	
CN599	* 1-560-061-00	PIN, CONNECTOR 3P		IC202	8-759-900-72	IC NE5532P	
CN701	* 1-564-321-00	PIN, CONNECTOR 2P		IC501	8-759-900-72	IC NE5532P	
CN702	* 1-564-321-00	PIN, CONNECTOR 2P		IC502	8-752-018-80	IC CX20188	
CNE501	* 1-564-507-11	PLUG, CONNECTOR 4P		IC503	8-759-945-58	IC RC4558P	
CNE502	* 1-564-511-11	PLUG, CONNECTOR 8P		IC507	8-759-511-57	IC ADJ712JN-SK	
CNE503	* 1-564-509-11	PLUG, CONNECTOR 6P		IC601	8-759-635-68	IC M50940-313SP	
CNE504	* 1-564-507-11	PLUG, CONNECTOR 4P		IC602	8-759-240-69	IC TC4069UBP	
CNE505	* 1-564-506-11	PLUG, CONNECTOR 3P		IC881	8-759-322-98	IC HD404240A31S	
CNN501	* 1-560-062-00	PIN, CONNECTOR 4P		IC882	8-741-100-48	IC SBX1610-59	
CNN502	* 1-560-062-00	PIN, CONNECTOR 4P				( JACK )	
CNN503	* 1-560-062-00	PIN, CONNECTOR 4P		J501	* 1-569-186-11	JACK, PIN 4P (LINE IN/CD DIRECTION)	
CNN504	* 1-560-065-00	PIN, CONNECTOR 8P		J502	* 1-568-250-21	JACK, PIN 2P (LINE OUT)	
CNS501	1-564-104-00	PIN, CONNECTOR 3P		J503	1-507-796-71	JACK (PHONES)	
CNS502	1-564-104-00	PIN, CONNECTOR 3P				( TRANSISTOR )	
		( COMPOSITION )		Q101	8-729-217-03	TRANSISTOR 2SK170-BL	
CP601	1-232-881-11	COMPOSITION CIRCUIT BLOCK		Q102	8-729-217-03	TRANSISTOR 2SK170-BL	
CP602	1-236-985-11	COMPOSITION CIRCUIT BLOCK		Q103	8-729-375-61	TRANSISTOR 2SD660-C	
		( DIODE )		Q104	8-729-201-56	TRANSISTOR 2SK246-GR2	
D501	8-719-107-94	DIODE 1SS202-1		Q105	8-729-194-57	TRANSISTOR 2SC945-P	
D502	8-719-107-94	DIODE 1SS202-1		Q106	8-729-141-30	TRANSISTOR 2SC3623A-LK	
D503	8-719-114-29	DIODE RD5.1JS-B1		Q201	8-729-217-03	TRANSISTOR 2SK170-BL	
D509	8-719-910-65	DIODE HZ6B2L		Q202	8-729-217-03	TRANSISTOR 2SK170-BL	
D510	8-719-910-65	DIODE HZ6B2L		Q203	8-729-375-61	TRANSISTOR 2SD666-C	
D519	8-719-107-94	DIODE 1SS202-1		Q204	8-729-201-56	TRANSISTOR 2SK246-GR2	
D520	8-719-107-94	DIODE 1SS202-1		Q205	8-729-194-57	TRANSISTOR 2SC945-P	
D521	8-719-107-94	DIODE 1SS202-1		Q206	8-729-141-30	TRANSISTOR 2SC3623A-LK	
D524	8-719-107-94	DIODE 1SS202-1		Q501	8-729-900-61	TRANSISTOR DTA114ES	
D601	8-719-107-94	DIODE 1SS202-1		Q502	8-729-900-89	TRANSISTOR DTC144ES	
D602	8-719-107-94	DIODE 1SS202-1		Q503	8-729-900-74	TRANSISTOR DTC143TS	
D603	8-719-107-94	DIODE 1SS202-1					
D604	8-719-107-94	DIODE 1SS202-1					

PB	COUNTER	AC SW	TIMER SW	REC VOL	REC EQ SW
----	---------	-------	----------	---------	-----------

H.P. AMP	PIN JACK	MONITOR SW
----------	----------	------------

Ref. No.	Part No.	Description	Remark	Ref. No.	Part No.	Description	Remark
Q504	8-729-620-05	TRANSISTOR	2SC2603-EF	R131	1-247-710-11	CARBON	560 5% 1/4W
Q505	8-729-900-74	TRANSISTOR	DTC143TS	R132	1-246-545-00	CARBON	1.0M 5% 1/4W
Q506	8-729-900-89	TRANSISTOR	DTC144ES	R133	1-249-462-11	CARBON	22K 5% 1/4W
Q507	8-729-119-76	TRANSISTOR	2SA1175-HFE	R134	1-247-152-00	CARBON	7.5K 5% 1/4W
Q508	8-729-900-89	TRANSISTOR	DTC144ES	R135	1-247-711-11	CARBON	680 5% 1/4W
Q509	8-729-107-53	TRANSISTOR	2SC2275A	R136	1-247-154-00	CARBON	9.1K 5% 1/4W
Q510	8-729-375-61	TRANSISTOR	2SD666A	R137	1-249-465-11	CARBON	47K 5% 1/4W
Q511	8-729-375-61	TRANSISTOR	2SD666A	R155	1-247-721-11	CARBON	4.7K 5% 1/4W
Q512	8-729-201-56	TRANSISTOR	2SK246-GR2	R156	1-247-152-00	CARBON	8.2K 5% 1/4W
Q513	8-729-190-53	TRANSISTOR	2SA985A	R157	1-247-725-11	CARBON	10K 5% 1/4W
Q514	8-729-371-61	TRANSISTOR	2SB716	R158	1-247-721-11	CARBON	4.7K 5% 1/4W
Q515	8-729-371-61	TRANSISTOR	2SB716	R159	1-259-500-11	CARBON	1M 5% 1/6W
Q516	8-729-201-56	TRANSISTOR	2SK246-GR2	R160	1-249-462-11	CARBON	22K 5% 1/4W
Q537	8-729-371-61	TRANSISTOR	2SB716	R181	1-247-725-11	CARBON	10K 5% 1/4W
Q538	8-729-375-61	TRANSISTOR	2SD666A	R182	1-249-461-11	CARBON	18K 5% 1/4W
Q601	8-729-900-61	TRANSISTOR	DTA114ES	R183	1-249-469-11	CARBON	100K 5% 1/4W
Q602	8-729-900-61	TRANSISTOR	DTA114ES	R184	1-247-704-11	CARBON	220 5% 1/4W
Q603	8-729-900-65	TRANSISTOR	DTA144ES	R190	1-247-749-11	CARBON	560 5% 1/2W
Q604	8-729-900-65	TRANSISTOR	DTA144ES	R191	1-246-545-00	CARBON	1.0M 5% 1/4W
Q605	8-729-900-65	TRANSISTOR	DTA144ES	R192	1-246-545-00	CARBON	1.0M 5% 1/4W
Q606	8-729-900-65	TRANSISTOR	DTA144ES	R193	1-249-490-11	CARBON	27K 5% 1/2W
Q607	8-729-900-65	TRANSISTOR	DTA144ES	R196	1-215-472-00	METAL	130K 1% 1/6W
Q608	8-729-900-65	TRANSISTOR	DTA144ES	R201	1-249-844-11	CARBON	56K 5% 1/2W
Q609	8-729-900-89	TRANSISTOR	DTC144ES	R202	1-247-128-00	CARBON	750 5% 1/4W
Q610	8-729-900-65	TRANSISTOR	DTA144ES	R203	1-247-128-00	CARBON	750 5% 1/4W
Q611	8-729-900-65	TRANSISTOR	DTA144ES	R204	1-249-504-11	CARBON	10 5% 1/4W
		< RESISTOR >		R205	1-247-708-11	CARBON	470 5% 1/4W
R101	1-249-844-11	CARBON	56K 5% 1/2W	R206	1-249-518-11	CARBON	39 5% 1/4W
R102	1-247-128-00	CARBON	750 5% 1/4W	R207	1-247-721-11	CARBON	4.7K 5% 1/4W
R103	1-247-128-00	CARBON	750 5% 1/4W	R208	1-247-704-11	CARBON	220 5% 1/4W
R104	1-249-504-11	CARBON	10 5% 1/4W	R209	1-249-723-11	CARBON	120K 5% 1/2W
R105	1-247-708-11	CARBON	470 5% 1/4W	R210	1-247-255-00	CARBON	4.3K 5% 1/2W
R106	1-249-518-11	CARBON	39 5% 1/4W	R211	1-249-462-11	CARBON	22K 5% 1/4W
R107	1-247-721-11	CARBON	4.7K 5% 1/4W	R212	1-247-740-11	CARBON	120 5% 1/2W
R108	1-247-704-11	CARBON	220 5% 1/4W	R213	1-249-658-11	CARBON	240 5% 1/2W
R109	1-249-723-11	CARBON	120K 5% 1/2W	R214	1-214-851-00	METAL	300 1% 1/2W
R110	1-247-255-00	CARBON	4.3K 5% 1/2W	R215	1-247-764-11	CARBON	10K 5% 1/2W
R111	1-249-462-11	CARBON	22K 5% 1/4W	R216	1-249-429-11	CARBON	10K 5% 1/4W
R112	1-247-740-11	CARBON	120 5% 1/2W	R217	1-247-720-11	CARBON	3.9K 5% 1/4W
R113	1-249-658-11	CARBON	240 5% 1/2W	R218	1-247-718-11	CARBON	2.7K 5% 1/4W
R114	1-214-851-00	METAL	300 1% 1/2W	R219	1-247-718-11	CARBON	2.7K 5% 1/4W
R115	1-247-764-11	CARBON	10K 5% 1/2W	R220	1-247-721-11	CARBON	4.7K 5% 1/4W
R116	1-249-429-11	CARBON	10K 5% 1/4W	R221	1-247-146-00	CARBON	4.3K 5% 1/4W
R117	1-247-720-11	CARBON	3.9K 5% 1/4W	R222	1-247-718-11	CARBON	2.7K 5% 1/4W
R118	1-247-718-11	CARBON	2.7K 5% 1/4W	R223	1-247-718-11	CARBON	2.7K 5% 1/4W
R119	1-247-718-11	CARBON	2.7K 5% 1/4W	R224	1-247-719-11	CARBON	3.3K 5% 1/4W
R120	1-247-721-11	CARBON	4.7K 5% 1/4W	R225	1-249-926-11	CARBON	1.3K 5% 1/4W
R121	1-247-146-00	CARBON	4.3K 5% 1/4W	R226	1-247-891-00	CARBON	330K 5% 1/4W
R122	1-247-718-11	CARBON	2.7K 5% 1/4W	R227	1-247-749-11	CARBON	560 5% 1/2W
R123	1-247-718-11	CARBON	2.7K 5% 1/4W	R228	1-247-764-11	CARBON	10K 5% 1/2W
R124	1-247-719-11	CARBON	3.3K 5% 1/4W	R229	1-247-146-00	CARBON	4.3K 5% 1/4W
R125	1-249-926-11	CARBON	1.3K 5% 1/4W	R230	1-247-142-00	CARBON	3K 5% 1/4W
R126	1-247-891-00	CARBON	330K 5% 1/4W	R231	1-247-710-11	CARBON	560 5% 1/4W
R127	1-247-749-11	CARBON	560 5% 1/2W	R232	1-246-545-00	CARBON	1.0M 5% 1/4W
R128	1-247-764-11	CARBON	10K 5% 1/2W	R233	1-249-462-11	CARBON	22K 5% 1/4W
R129	1-247-146-00	CARBON	4.3K 5% 1/4W	R234	1-247-152-00	CARBON	7.5K 5% 1/4W
R130	1-247-142-00	CARBON	3K 5% 1/4W	R235	1-247-711-11	CARBON	680 5% 1/4W
				R236	1-247-154-00	CARBON	9.1K 5% 1/4W
				R237	1-249-465-11	CARBON	47K 5% 1/4W
				R255	1-247-721-11	CARBON	4.7K 5% 1/4W

**PB COUNTER AC SW TIMER SW REC VOL REC EQ SW**

**H.P. AMP PIN JACK MONITOR SW**

Ref. No.	Part No.	Description	Remark			Ref. No.	Part No.	Description	Remark		
R256	1-247-152-00	CARBON	8. 2K	5%	1/4W	R604	1-247-903-00	CARBON	1M	5%	1/4W
R257	1-247-725-11	CARBON	10K	5%	1/4W	R605	1-247-895-00	CARBON	470K	5%	1/4W
R258	1-247-721-11	CARBON	4. 7K	5%	1/4W	R606	1-249-433-11	CARBON	22K	5%	1/4W
R259	1-259-500-11	CARBON	1M	5%	1/6W	R607	1-249-433-11	CARBON	22K	5%	1/4W
R260	1-249-462-11	CARBON	22K	5%	1/4W	R608	1-249-437-11	CARBON	47K	5%	1/4W
R281	1-247-725-11	CARBON	10K	5%	1/4W	R609	1-249-437-11	CARBON	47K	5%	1/4W
R282	1-249-461-11	CARBON	18K	5%	1/4W	R610	1-249-437-11	CARBON	47K	5%	1/4W
R283	1-249-469-11	CARBON	100K	5%	1/4W	R611	1-249-437-11	CARBON	47K	5%	1/4W
R284	1-247-704-11	CARBON	220	5%	1/4W	R612	1-249-437-11	CARBON	47K	5%	1/4W
R290	1-247-749-11	CARBON	560	5%	1/2W	R613	1-249-437-11	CARBON	47K	5%	1/4W
R291	1-246-545-00	CARBON	1. 0M	5%	1/4W	R614	1-249-421-11	CARBON	2. 2K	5%	1/4W
R292	1-246-545-00	CARBON	1. 0M	5%	1/4W	R615	1-249-421-11	CARBON	2. 2K	5%	1/4W
R293	1-249-490-11	CARBON	27K	5%	1/2W	R616	1-249-429-11	CARBON	10K	5%	1/4W
R321	1-249-824-11	CARBON	8. 2K	5%	1/2W	R617	1-249-437-11	CARBON	47K	5%	1/4W
R322	1-259-500-11	CARBON	1M	5%	1/6W	R618	1-247-842-11	CARBON	3K	5%	1/4W
R323	1-259-436-11	CARBON	2. 2K	5%	1/6W	R619	1-249-426-11	CARBON	5. 6K	5%	1/4W
R421	1-249-824-11	CARBON	8. 2K	5%	1/2W	R620	1-249-437-11	CARBON	47K	5%	1/4W
R422	1-259-500-11	CARBON	1M	5%	1/6W	R621	1-249-421-11	CARBON	2. 2K	5%	1/4W
R423	1-259-436-11	CARBON	2. 2K	5%	1/6W	R622	1-249-421-11	CARBON	2. 2K	5%	1/4W
R501	1-249-434-11	CARBON	27K	5%	1/4W	R699	1-247-764-11	CARBON	10K	5%	1/2W
R502	1-249-429-11	CARBON	10K	5%	1/4W	R881	1-247-903-00	CARBON	1M	5%	1/4W
R503	1-249-425-11	CARBON	4. 7K	5%	1/4W	R882	1-249-433-11	CARBON	22K	5%	1/4W
R504	1-249-433-11	CARBON	22K	5%	1/4W	R883	1-249-425-11	CARBON	4. 7K	5%	1/4W
R506	1-249-429-11	CARBON	10K	5%	1/4W	R884	1-249-425-11	CARBON	4. 7K	5%	1/4W
R507	1-249-417-11	CARBON	1K	5%	1/4W	R885	1-249-422-11	CARBON	2. 7K	5%	1/4W
R508	1-249-435-11	CARBON	33K	5%	1/4W	R886	1-249-424-11	CARBON	3. 9K	5%	1/4W
R509	1-249-429-11	CARBON	10K	5%	1/4W	R887	1-249-422-11	CARBON	2. 7K	5%	1/4W
R510	1-249-425-11	CARBON	4. 7K	5%	1/4W	R888	1-249-424-11	CARBON	3. 9K	5%	1/4W
R511	1-249-417-11	CARBON	1K	5%	1/4W	R889	1-249-428-11	CARBON	8. 2K	5%	1/4W
R512	1-249-434-11	CARBON	27K	5%	1/4W	R890	1-249-434-11	CARBON	27K	5%	1/4W
R513	1-249-429-11	CARBON	10K	5%	1/4W	R891	1-249-422-11	CARBON	2. 7K	5%	1/4W
R514	1-249-441-11	CARBON	100K	5%	1/4W	R892	1-249-424-11	CARBON	3. 9K	5%	1/4W
R515	1-249-417-11	CARBON	1K	5%	1/4W	R893	1-249-428-11	CARBON	8. 2K	5%	1/4W
R516	1-249-433-11	CARBON	22K	5%	1/4W	R894	1-249-434-11	CARBON	27K	5%	1/4W
R517	1-249-431-11	CARBON	15K	5%	1/4W	R895	1-249-424-11	CARBON	3. 9K	5%	1/4W
R518	1-249-429-11	CARBON	10K	5%	1/4W						< VARIABLE RESISTOR >
R519	1-249-433-11	CARBON	22K	5%	1/4W						
R521	1-247-749-11	CARBON	560	5%	1/2W	RV101	1-224-550-21	RES, ADJ, METAL GLAZE 220			
R522	1-249-673-11	CARBON	1K	5%	1/2W	RV201	1-224-550-21	RES, ADJ, METAL GLAZE 220			
R523	1-247-719-11	CARBON	3. 3K	5%	1/4W	RV501	1-230-344-11	RES, VAR, CARBON 20K/20K			
R524	1-249-547-11	CARBON	620	5%	1/4W	RV502	1-238-840-11	RES, VAR, CARBON 5K/5K			
R525	1-249-466-11	CARBON	56K	5%	1/4W	RV503	1-241-336-11	RES, VAR, CARBON 20K/20K			
R526	1-249-673-11	CARBON	1K	5%	1/2W						
R527	1-247-749-11	CARBON	560	5%	1/2W	RV601	1-241-335-11	RES, VAR, CARBON 5K			
R528	1-247-719-11	CARBON	3. 3K	5%	1/4W						< RELAY >
R529	1-249-547-11	CARBON	620	5%	1/4W						
R530	1-249-466-11	CARBON	56K	5%	1/4W	RY503	1-515-803-11	RELAY			< SWITCH >
R570	1-249-433-11	CARBON	22K	5%	1/4W						
R571	1-249-429-11	CARBON	10K	5%	1/4W						
R574	1-249-429-11	CARBON	10K	5%	1/4W						
R577	1-247-714-11	CARBON	1. 2K	5%	1/4W	S501	1-572-589-11	SWITCH, ROTARY (REC EQ CAL)			
R578	1-247-704-11	CARBON	220	5%	1/4W	S601	1-572-339-11	SWITCH, PUSH (1 KEY) (HX PRO)			
R579	1-247-714-11	CARBON	1. 2K	5%	1/4W	S602	1-572-339-11	SWITCH, PUSH (1 KEY) (CAL IBRATION)			
R580	1-247-704-11	CARBON	220	5%	1/4W	S603	1-554-833-11	SWITCH, PUSH (1 KEY) (INPUT:CD/LINE)			
R581	1-247-700-11	CARBON	100	5%	1/4W	S604	1-572-588-11	SWITCH, ROTARY (DOLBY NR)			
R582	1-247-700-11	CARBON	100	5%	1/4W	S605	1-572-590-11	SWITCH, ROTARY (MONITOR)			
R599	1-247-764-11	CARBON	10K	5%	1/2W	S701	△1-572-267-21	SWITCH, PUSH (AC POWER) (1 KEY) (POWER)			
R601	1-249-441-11	CARBON	100K	5%	1/4W	S881	1-554-303-21	SWITCH, TACTILE (RESET)			
R602	1-249-441-11	CARBON	100K	5%	1/4W	S882	1-554-303-21	SWITCH, TACTILE (MEMORY)			
R603	1-249-425-11	CARBON	4. 7K	5%	1/4W	S883	1-554-303-21	SWITCH, TACTILE (DISPLAY MODE)			

**Note:** The components identified by mark  $\Delta$  or dotted line with mark  $\Delta$  are critical for safety. Replace only with part number specified.

PB	COUNTER	AC SW	TIMER SW	REC VOL	REC EQ SW
		H.P. AMP	PIN JACK	MONITOR SW	RECT.

Ref. No.	Part No.	Description	Remark	Ref. No.	Part No.	Description	Remark
S884	1-554-303-21	SWITCH, TACTILE (▲)		C155	1-130-485-00	MYLAR	0.015uF 5% 50V
S885	1-554-303-21	SWITCH, TACTILE (■)		C156	1-136-160-00	FILM	0.039uF 5% 50V
S886	1-554-303-21	SWITCH, TACTILE (◀)		C157	1-130-486-00	MYLAR	0.018uF 10% 50V
S887	1-554-303-21	SWITCH, TACTILE (▶)		C159	1-124-929-11	ELECT	22uF 20% 100V
S888	1-554-303-21	SWITCH, TACTILE (●)		C160	1-136-252-00	FILM	0.0015uF 5% 100V
S889	1-554-303-21	SWITCH, TACTILE (▶)		C161	1-107-157-00	MICA	27PF 5% 500V
S890	1-554-303-21	SWITCH, TACTILE (■)		C162	1-107-159-00	MICA	33PF 5% 500V
S891	1-554-303-21	SWITCH, TACTILE (■)		C163	1-107-169-00	MICA	100PF 5% 500V
S892	1-554-303-21	SWITCH, TACTILE (■)		C164	1-109-627-00	MICA	150PF 2% 500V
S893	1-554-303-21	SWITCH, TACTILE (○)		C165	1-109-621-00	MICA	220PF 1% 500V
S894	1-570-903-11	SWITCH, SLIDE (TIMER) ( VIBRATOR )		C166	1-136-153-00	FILM	0.01uF 5% 50V
X601	1-577-358-21	VIBRATOR, CERAMIC		C167	1-136-163-00	FILM	0.068uF 5% 50V
X881	1-577-358-21	VIBRATOR, CERAMIC		C168	1-136-157-00	FILM	0.022uF 5% 50V
*****							
	* 1-637-512-11	RECT. BOARD *****		C170	1-124-925-11	ELECT	2.2uF 20% 100V
	* 1-533-213-31	HOLDER, FUSE		C171	1-123-382-00	ELECT	3.3uF 20% 100V
	* 3-346-266-12	PLATE, GROUND		C173	1-124-925-11	ELECT	2.2uF 20% 100V
	* 3-356-925-01	HEAT SINK		C174	1-136-165-00	FILM	0.1uF 5% 50V
	* 4-363-146-21	HEAT SINK, V. OUT		C228	1-123-369-00	ELECT	4.7uF 20% 63V
	7-685-646-79	SCREW +BVTP 3X8 TYPE2 IT-3		C229	1-123-369-00	ELECT	4.7uF 20% 63V
	7-682-547-04	SCREW +BVTT 3X6 (S) ( CAPACITOR )		C230	1-124-767-00	ELECT	2.2uF 20% 50V
C128	1-123-369-00	ELECT	4.7uF 20% 63V	C231	1-107-159-00	MICA	33PF 5% 500V
C129	1-123-369-00	ELECT	4.7uF 20% 63V	C232	1-107-159-00	MICA	33PF 5% 500V
C130	1-124-767-00	ELECT	2.2uF 20% 50V	C233	1-130-475-00	MYLAR	0.0022uF 5% 50V
C131	1-107-159-00	MICA	33PF 5% 500V	C234	1-130-475-00	MYLAR	0.0022uF 5% 50V
C132	1-107-159-00	MICA	33PF 5% 500V	C235	1-130-478-00	MYLAR	0.0039uF 5% 50V
C133	1-130-475-00	MYLAR	0.0022uF 5% 50V	C236	1-136-173-00	FILM	0.47uF 5% 50V
C134	1-130-475-00	MYLAR	0.0022uF 5% 50V	C237	1-136-167-00	FILM	0.15uF 5% 50V
C135	1-130-478-00	MYLAR	0.0039uF 5% 50V	C238	1-136-155-00	FILM	0.015uF 5% 50V
C136	1-136-173-00	FILM	0.47uF 5% 50V	C239	1-123-380-00	ELECT	1uF 20% 50V
C137	1-136-167-00	FILM	0.15uF 5% 50V	C240	1-136-169-00	FILM	0.22uF 5% 50V
C138	1-136-155-00	FILM	0.015uF 5% 50V	C241	1-136-163-00	FILM	0.068uF 5% 50V
C139	1-123-380-00	ELECT	1uF 20% 50V	C242	1-136-162-00	FILM	0.056uF 5% 50V
C140	1-136-169-00	FILM	0.22uF 5% 50V	C243	1-123-380-00	ELECT	1uF 20% 50V
C141	1-136-163-00	FILM	0.068uF 5% 50V	C244	1-130-480-00	MYLAR	0.0056uF 5% 50V
C142	1-136-162-00	FILM	0.056uF 5% 50V	C245	1-136-153-00	FILM	0.01uF 5% 50V
C143	1-123-380-00	ELECT	1uF 20% 50V	C246	1-124-929-11	ELECT	22uF 20% 100V
C144	1-130-480-00	MYLAR	0.0056uF 5% 50V	C247	1-124-929-11	ELECT	22uF 20% 100V
C145	1-136-153-00	FILM	0.01uF 5% 50V	C250	1-136-252-00	FILM	0.0015uF 5% 100V
C146	1-124-929-11	ELECT	22uF 20% 100V	C251	1-124-915-11	ELECT	10uF 20% 63V
C147	1-124-929-11	ELECT	22uF 20% 100V	C252	1-136-163-00	FILM	0.068uF 5% 50V
C150	1-136-252-00	FILM	0.0015uF 5% 100V	C253	1-130-485-00	MYLAR	0.015uF 5% 50V
C151	1-124-915-11	ELECT	10uF 20% 63V	C254	1-136-160-00	FILM	0.039uF 5% 50V
C152	1-136-163-00	FILM	0.068uF 5% 50V	C255	1-130-485-00	MYLAR	0.015uF 5% 50V
C153	1-130-485-00	MYLAR	0.015uF 5% 50V	C256	1-136-160-00	FILM	0.039uF 5% 50V
C154	1-136-160-00	FILM	0.039uF 5% 50V	C257	1-130-486-00	MYLAR	0.018uF 10% 50V
				C259	1-124-929-11	ELECT	22uF 20% 100V
				C260	1-136-252-00	FILM	0.0015uF 5% 100V
				C261	1-107-157-00	MICA	27PF 5% 500V
				C262	1-107-159-00	MICA	33PF 5% 500V
				C263	1-107-169-00	MICA	100PF 5% 500V
				C264	1-109-627-00	MICA	150PF 2% 500V
				C265	1-109-621-00	MICA	220PF 1% 500V
				C266	1-136-153-00	FILM	0.01uF 5% 50V
				C267	1-136-163-00	FILM	0.068uF 5% 50V
				C268	1-136-157-00	FILM	0.022uF 5% 50V
				C270	1-124-925-11	ELECT	2.2uF 20% 100V
				C271	1-123-382-00	ELECT	3.3uF 20% 100V
				C272	1-161-375-00	CERAMIC	0.0022uF 20% 50V
				C273	1-124-925-11	ELECT	2.2uF 20% 100V
				C515	1-124-907-11	ELECT	10uF 20% 50V

## RECT.

Ref. No.	Part No.	Description	Remark			Ref. No.	Part No.	Description	Remark		
C516	1-123-369-00	ELECT	4.7uF	20%	63V	C806	1-162-294-31	CERAMIC	0.001uF	10%	50V
C517	1-123-369-00	ELECT	4.7uF	20%	63V	C807	1-162-294-31	CERAMIC	0.001uF	10%	50V
C520	1-123-369-00	ELECT	4.7uF	20%	63V			< CONNECTOR >			
C521	1-124-477-11	ELECT	47uF	20%	25V						
C522	1-123-369-00	ELECT	4.7uF	20%	63V	CN703	* 1-564-104-00	PIN, CONNECTOR	3P		
C523	1-124-477-11	ELECT	47uF	20%	25V	CN704	* 1-564-506-11	PLUG, CONNECTOR	3P		
C524	1-124-903-11	ELECT	1uF	20%	50V	CN705	* 1-564-506-11	PLUG, CONNECTOR	3P		
C525	1-124-907-11	ELECT	10uF	20%	50V	CN751	* 1-564-511-11	PLUG, CONNECTOR	8P		
C528	1-107-026-00	MICA	5.1PF		500V	CN801	* 1-564-336-00	PIN, CONNECTOR	2P		
C529	1-124-477-11	ELECT	47uF	20%	25V	CN802	* 1-564-341-11	PIN, CONNECTOR	7P		
C530	1-124-925-11	ELECT	2.2uF	20%	100V	CN803	* 1-506-503-71	PIN, CONNECTOR	9P		
C531	1-124-915-11	ELECT	10uF	20%	63V	CN804	* 1-506-503-11	PIN, CONNECTOR	9P		
C532	1-124-477-11	ELECT	47uF	20%	25V	CN805	* 1-564-339-00	PIN, CONNECTOR	5P		
C533	1-124-915-11	ELECT	10uF	20%	63V	CN806	* 1-564-666-11	PIN, CONNECTOR	10P		
C534	1-124-477-11	ELECT	47uF	20%	25V	CN807	* 1-564-342-61	PIN, CONNECTOR	8P		
C535	1-124-477-11	ELECT	47uF	20%	25V	CN809	* 1-506-503-11	PIN, CONNECTOR	9P		
C536	1-124-477-11	ELECT	47uF	20%	25V	CND501	* 1-564-340-00	PIN, CONNECTOR	6P		
C537	1-130-474-00	MYLAR	0.0018uF	5%	50V	CND502	* 1-564-341-11	PIN, CONNECTOR	7P		
C538	1-130-474-00	MYLAR	0.0018uF	5%	50V	CNE101	* 1-564-507-11	PLUG, CONNECTOR	4P		
C539	1-136-157-00	FILM	0.022uF	5%	50V	CNE201	* 1-564-507-11	PLUG, CONNECTOR	4P		
C540	1-136-157-00	FILM	0.022uF	5%	50V	CNE504	* 1-564-506-11	PLUG, CONNECTOR	3P		
C541	1-124-907-11	ELECT	10uF	20%	50V	CNN505	* 1-560-062-00	PIN, CONNECTOR	4P		
C542	1-126-233-11	ELECT	22uF	20%	50V	CNN506	* 1-560-061-00	PIN, CONNECTOR	3P		
C543	1-162-217-31	CERAMIC	56PF	5%	50V			< OSCILLATION UNIT >			
C544	1-162-217-31	CERAMIC	56PF	5%	50V	CP501	1-466-252-11	OSCILLATION UNIT, BIAS			
C545	1-124-477-11	ELECT	47uF	20%	25V			< DIODE >			
C546	1-164-159-11	CERAMIC	0.1uF		50V	D101	8-719-000-60	DIODE	UZL-6M2		
C702	1-136-165-00	FILM	0.1uF	5%	50V	D102	8-719-107-94	DIODE	1SS202-1		
C703	1-136-177-00	FILM	1uF	5%	50V	D103	8-719-107-94	DIODE	1SS202-1		
C704	1-126-982-11	ELECT	5600uF	20%	0	D201	8-719-000-60	DIODE	UZL-6M2		
C705	1-126-982-11	ELECT	5600uF	20%	0	D202	8-719-107-94	DIODE	1SS202-1		
C706	1-124-636-00	ELECT	3300uF	20%	25V	D203	8-719-107-94	DIODE	1SS202-1		
C707	1-124-120-11	ELECT	220uF	20%	25V	D511	8-719-114-29	DIODE	RD5.1JS-B1		
C708	1-124-479-11	ELECT	330uF	20%	25V	D512	8-719-107-94	DIODE	1SS202-1		
C709	1-124-911-11	ELECT	220uF	20%	50V	D514	8-719-107-94	DIODE	1SS202-1		
C710	1-124-767-00	ELECT	2.2uF	20%	50V	D515	8-719-107-94	DIODE	1SS202-1		
C711	1-162-294-31	CERAMIC	0.001uF	10%	50V	D516	8-719-114-29	DIODE	RD5.1JS-B1		
C712	1-162-294-31	CERAMIC	0.001uF	10%	50V	D517	8-719-107-94	DIODE	1SS202-1		
C751	1-124-636-00	ELECT	3300uF	20%	25V	D522	8-719-107-94	DIODE	1SS202-1		
C752	1-124-907-11	ELECT	10uF	20%	50V	D523	8-719-933-41	DIODE	HZS6C3L		
C753	1-124-122-11	ELECT	100uF	20%	50V	D525	8-719-107-94	DIODE	1SS202-1		
C754	1-124-927-11	ELECT	4.7uF	20%	100V	D526	8-719-107-94	DIODE	1SS202-1		
C755	1-126-101-11	ELECT	100uF	20%	16V	D527	8-719-114-29	DIODE	RD5.1JS-B1		
C756	1-124-898-11	ELECT	4700uF	20%	16V	D701	8-719-230-02	DIODE	30DF2		
C757	1-124-907-11	ELECT	10uF	20%	50V	D702	8-719-230-02	DIODE	30DF2		
C758	1-162-211-31	CERAMIC	33PF	5%	50V	D703	8-719-230-02	DIODE	30DF2		
C759	1-124-472-11	ELECT	470uF	20%	10V	D704	8-719-230-02	DIODE	30DF2		
C760	1-124-903-11	ELECT	1uF	20%	50V	D705	8-719-200-77	DIODE	10E2N		
C761	1-124-471-00	ELECT	1000uF	20%	6.3V	D706	8-719-200-77	DIODE	10E2N		
C762	1-124-903-11	ELECT	1uF	20%	50V	D707	8-719-200-77	DIODE	10E2N		
C763	1-124-903-11	ELECT	1uF	20%	50V	D708	8-719-200-77	DIODE	10E2N		
C764	1-124-443-00	ELECT	100uF	20%	10V	D709	8-719-200-77	DIODE	10E2N		
C765	1-124-907-11	ELECT	10uF	20%	50V	D710	8-719-200-77	DIODE	10E2N		
C766	1-124-122-11	ELECT	100uF	20%	50V	D711	8-719-107-94	DIODE	1SS202-1		
C767	1-124-443-00	ELECT	100uF	20%	10V	D712	8-719-107-94	DIODE	1SS202-1		
C801	1-164-159-11	CERAMIC	0.1uF		50V	D751	8-719-200-77	DIODE	10E2N		
C802	1-164-159-11	CERAMIC	0.1uF		50V						
C803	1-124-477-11	ELECT	47uF	20%	25V						
C804	1-124-907-11	ELECT	10uF	20%	50V						
C805	1-124-443-00	ELECT	100uF	20%	10V						



RECT.

Ref. No.	Part No.	Description	Remark	Ref. No.	Part No.	Description	Remark
D752	8-719-910-25	DIODE HZS12B2L		Q110	8-729-141-30	TRANSISTOR 2SC3623A-LK	
D753	8-719-933-39	DIODE HZS6C1L		Q111	8-729-141-30	TRANSISTOR 2SC3623A-LK	
D754	8-719-933-41	DIODE HZS6C3L		Q112	8-729-900-80	TRANSISTOR DTC114ES	
D755	8-719-933-39	DIODE HZS6C1L		Q113	8-729-900-80	TRANSISTOR DTC114ES	
D756	8-719-002-33	DIODE UZL-24L		Q114	8-729-900-80	TRANSISTOR DTC114ES	
D757	8-719-200-77	DIODE 10E2N		Q116	8-729-141-30	TRANSISTOR 2SC3623A-LK	
D758	8-719-933-39	DIODE HZS6C1L		Q117	8-729-141-30	TRANSISTOR 2SC3623A-LK	
D801	8-719-107-94	DIODE 1SS202-1		Q118	8-729-141-30	TRANSISTOR 2SC3623A-LK	
D802	8-719-107-94	DIODE 1SS202-1		Q207	8-729-142-25	TRANSISTOR 2SD1020-HFE	
		< IC >		Q208	8-729-141-30	TRANSISTOR 2SC3623A-LK	
IC504	8-759-602-83	IC M5238P		Q209	8-729-141-30	TRANSISTOR 2SC3623A-LK	
IC505	8-752-018-80	IC CX20188		Q210	8-729-141-30	TRANSISTOR 2SC3623A-LK	
IC506	8-759-900-72	IC NE5532P		Q211	8-729-141-30	TRANSISTOR 2SC3623A-LK	
IC508	8-759-106-56	IC $\mu$ PC1297CA		Q212	8-729-900-80	TRANSISTOR DTC114ES	
IC509	8-759-604-86	IC M5F7807		Q213	8-729-900-80	TRANSISTOR DTC114ES	
IC510	8-759-604-90	IC M5F7907		Q214	8-729-900-80	TRANSISTOR DTC114ES	
IC511	8-759-240-50	IC TC4050BP		Q216	8-729-141-30	TRANSISTOR 2SC3623A-LK	
IC512	8-759-602-83	IC M5238P		Q217	8-729-141-30	TRANSISTOR 2SC3623A-LK	
IC513	8-759-945-58	IC RC4558P		Q218	8-729-141-30	TRANSISTOR 2SC3623A-LK	
IC514	8-759-634-51	IC M5218AP		Q517	8-729-900-61	TRANSISTOR DTA114ES	
IC515	8-759-945-58	IC RC4558P		Q518	8-729-281-53	TRANSISTOR 2SC1815-GR	
IC518	8-759-982-26	IC RC78L12A		Q519	8-729-119-76	TRANSISTOR 2SA1175-HFE	
IC519	8-759-982-48	IC RC79L12A		Q520	8-729-900-36	TRANSISTOR DTC124ES	
IC801	8-759-635-69	IC M50964-226SP		Q522	8-729-141-30	TRANSISTOR 2SC3623ATP-LK	
IC802	8-759-973-95	IC BA6219B		Q523	8-729-141-30	TRANSISTOR 2SC3623ATP-LK	
IC803	8-759-822-09	IC LB1641		Q524	8-729-141-30	TRANSISTOR 2SC3623ATP-LK	
		< COIL >		Q529	8-729-141-30	TRANSISTOR 2SC3623ATP-LK	
L101	1-408-920-00	INDUCTOR 4.7mH		Q530	8-729-141-30	TRANSISTOR 2SC3623ATP-LK	
L102	1-408-918-11	INDUCTOR 3.3mH		Q533	8-729-900-36	TRANSISTOR DTC124ES	
L103	1-408-916-11	INDUCTOR 2.2mH		Q534	8-729-900-74	TRANSISTOR DTC143TS	
L104	1-408-925-11	INDUCTOR 12mH		Q535	8-729-900-36	TRANSISTOR DTC124ES	
L105	1-408-916-11	INDUCTOR 2.2mH		Q536	8-729-900-36	TRANSISTOR DTC124ES	
L201	1-408-920-00	INDUCTOR 4.7mH		Q539	8-729-900-36	TRANSISTOR DTC124ES	
L202	1-408-918-11	INDUCTOR 3.3mH		Q540	8-729-620-05	TRANSISTOR 2SC2603-EF	
L203	1-408-916-11	INDUCTOR 2.2mH		Q701	8-729-620-05	TRANSISTOR 2SC2603-EF	
L204	1-408-925-11	INDUCTOR 12mH		Q751	8-729-924-90	TRANSISTOR 2SB1370-EF	
L205	1-408-916-11	INDUCTOR 2.2mH		Q752	8-729-924-90	TRANSISTOR 2SB1370-EF	
L501	1-410-525-11	INDUCTOR 220 $\mu$ H		Q753	8-729-111-55	TRANSISTOR 2SD2061-EF	
L502	1-410-525-11	INDUCTOR 220 $\mu$ H		Q754	8-729-119-76	TRANSISTOR 2SA1175-HFE	
L503	1-410-525-11	INDUCTOR 220 $\mu$ H		Q755	8-729-140-97	TRANSISTOR 2SB734-34	
		< PILOT LAMP >		Q756	8-729-620-05	TRANSISTOR 2SC2603-EF	
LP501	1-518-471-31	LAMP, PILOT		Q757	8-729-620-05	TRANSISTOR 2SC2603-EF	
LP502	1-518-471-31	LAMP, PILOT		Q758	8-729-620-05	TRANSISTOR 2SC2603-EF	
		< FILTER >		Q759	8-729-620-05	TRANSISTOR 2SC2603-EF	
LPF101	1-236-087-11	FILTER, LOW PASS		Q801	8-729-119-76	TRANSISTOR 2SA1175-HFE	
LPF201	1-236-087-11	FILTER, LOW PASS		Q802	8-729-119-76	TRANSISTOR 2SA1175-HFE	
		< IC LINK >		Q803	8-729-620-05	TRANSISTOR 2SC2603-EF	
PS701	1-532-685-00	LINK, IC		Q804	8-729-620-05	TRANSISTOR 2SC2603-EF	
PS702	1-532-685-00	LINK, IC		Q805	8-729-900-61	TRANSISTOR DTA114ES	
		< TRANSISTOR >		Q806	8-729-900-61	TRANSISTOR DTA114ES	
Q107	8-729-142-25	TRANSISTOR 2SD1020TP-HFE		Q807	8-729-900-61	TRANSISTOR DTA114ES	
Q108	8-729-141-30	TRANSISTOR 2SC3623A-LK		Q808	8-729-900-61	TRANSISTOR DTA114ES	
Q109	8-729-141-30	TRANSISTOR 2SC3623A-LK		Q809	8-729-900-65	TRANSISTOR DTA144ES	
				Q810	8-729-900-65	TRANSISTOR DTA144ES	
				Q811	8-729-900-65	TRANSISTOR DTA144ES	
				Q812	8-729-900-65	TRANSISTOR DTA144ES	
				Q813	8-729-900-65	TRANSISTOR DTA144ES	
				Q814	8-729-900-65	TRANSISTOR DTA144ES	
				Q815	8-729-900-61	TRANSISTOR DTA114ES	
				Q816	8-729-900-61	TRANSISTOR DTA114ES	



**RECT.**

Ref. No.	Part No.	Description	Remark	Ref. No.	Part No.	Description	Remark
		( RESISTOR )					
R138	1-249-469-11	CARBON 100K 5%	1/4W	R249	1-246-545-00	CARBON 1.0M 5%	1/4W
R139	1-247-723-11	CARBON 6.8K 5%	1/4W	R250	1-249-462-11	CARBON 22K 5%	1/4W
R140	1-247-720-11	CARBON 3.9K 5%	1/4W	R251	1-247-152-00	CARBON 7.5K 5%	1/4W
R141	1-247-719-11	CARBON 3.3K 5%	1/4W	R252	1-247-711-11	CARBON 680 5%	1/4W
R142	1-247-152-00	CARBON 7.5K 5%	1/4W	R253	1-247-154-00	CARBON 9.1K 5%	1/4W
R143	1-249-469-11	CARBON 100K 5%	1/4W	R254	1-249-465-11	CARBON 47K 5%	1/4W
R144	1-247-747-11	CARBON 470 5%	1/2W	R261	1-247-719-11	CARBON 3.3K 5%	1/4W
R145	1-247-764-11	CARBON 10K 5%	1/2W	R262	1-247-723-11	CARBON 6.8K 5%	1/4W
R146	1-247-146-00	CARBON 4.3K 5%	1/4W	R263	1-249-590-11	CARBON 39K 5%	1/4W
R147	1-247-142-00	CARBON 3K 5%	1/4W	R264	1-249-425-11	CARBON 4.7K 5%	1/4W
R148	1-247-710-11	CARBON 560 5%	1/4W	R265	1-249-429-11	CARBON 10K 5%	1/4W
R149	1-246-545-00	CARBON 1.0M 5%	1/4W	R266	1-249-465-11	CARBON 47K 5%	1/4W
R150	1-249-462-11	CARBON 22K 5%	1/4W	R267	1-247-716-11	CARBON 1.8K 5%	1/4W
R151	1-247-152-00	CARBON 7.5K 5%	1/4W	R268	1-249-598-11	CARBON 82K 5%	1/4W
R152	1-247-711-11	CARBON 680 5%	1/4W	R269	1-259-467-11	CARBON 43K 5%	1/4W
R153	1-247-154-00	CARBON 9.1K 5%	1/4W	R270	1-247-702-11	CARBON 150 5%	1/4W
R154	1-249-465-11	CARBON 47K 5%	1/4W	R271	1-247-154-00	CARBON 9.1K 5%	1/4W
R161	1-247-719-11	CARBON 3.3K 5%	1/4W	R272	1-249-429-11	CARBON 10K 5%	1/4W
R162	1-247-723-11	CARBON 6.8K 5%	1/4W	R273	1-247-701-11	CARBON 120 5%	1/4W
R163	1-249-590-11	CARBON 39K 5%	1/4W	R274	1-247-142-00	CARBON 3K 5%	1/4W
R164	1-249-425-11	CARBON 4.7K 5%	1/4W	R275	1-247-721-11	CARBON 4.7K 5%	1/4W
R165	1-249-429-11	CARBON 10K 5%	1/4W	R276	1-249-429-11	CARBON 10K 5%	1/4W
R166	1-249-465-11	CARBON 47K 5%	1/4W	R277	1-247-700-11	CARBON 100 5%	1/4W
R167	1-247-716-11	CARBON 1.8K 5%	1/4W	R278	1-247-719-11	CARBON 3.3K 5%	1/4W
R168	1-249-598-11	CARBON 82K 5%	1/4W	R279	1-247-719-11	CARBON 3.3K 5%	1/4W
R169	1-259-467-11	CARBON 43K 5%	1/4W	R280	1-249-429-11	CARBON 10K 5%	1/4W
R170	1-247-702-11	CARBON 150 5%	1/4W	R285	1-247-718-11	CARBON 2.7K 5%	1/4W
R171	1-247-154-00	CARBON 9.1K 5%	1/4W	R286	1-247-883-00	CARBON 150K 5%	1/4W
R172	1-249-429-11	CARBON 10K 5%	1/4W	R287	1-247-714-11	CARBON 1.2K 5%	1/4W
R173	1-247-701-11	CARBON 120 5%	1/4W	R288	1-247-714-11	CARBON 1.2K 5%	1/4W
R174	1-247-142-00	CARBON 3K 5%	1/4W	R289	1-249-425-11	CARBON 4.7K 5%	1/4W
R175	1-247-721-11	CARBON 4.7K 5%	1/4W	R294	1-247-883-00	CARBON 150K 5%	1/4W
R176	1-249-429-11	CARBON 10K 5%	1/4W	R295	1-249-417-11	CARBON 1K 5%	1/4W
R177	1-247-700-11	CARBON 100 5%	1/4W	R296	1-215-472-00	METAL 130K 1%	1/6W
R178	1-247-719-11	CARBON 3.3K 5%	1/4W	R297	1-249-408-11	CARBON 180 5%	1/4W
R179	1-247-719-11	CARBON 3.3K 5%	1/4W	R298	1-249-414-11	CARBON 560 5%	1/4W
R180	1-249-429-11	CARBON 10K 5%	1/4W	R299	1-249-417-11	CARBON 1K 5%	1/4W
R185	1-247-718-11	CARBON 2.7K 5%	1/4W	R301	1-249-428-11	CARBON 8.2K 5%	1/4W
R186	1-247-883-00	CARBON 150K 5%	1/4W	R302	1-249-417-11	CARBON 1K 5%	1/4W
R187	1-247-714-11	CARBON 1.2K 5%	1/4W	R303	1-247-725-11	CARBON 10K 5%	1/4W
R188	1-247-714-11	CARBON 1.2K 5%	1/4W	R304	1-249-429-11	CARBON 10K 5%	1/4W
R189	1-249-425-11	CARBON 4.7K 5%	1/4W	R305	1-249-429-11	CARBON 10K 5%	1/4W
R194	1-247-883-00	CARBON 150K 5%	1/4W	R306	1-249-417-11	CARBON 1K 5%	1/4W
R195	1-249-417-11	CARBON 1K 5%	1/4W	R307	1-249-437-11	CARBON 47K 5%	1/4W
R197	1-249-408-11	CARBON 180 5%	1/4W	R308	1-215-465-00	METAL 68K 1%	1/6W
R198	1-249-414-11	CARBON 560 5%	1/4W	R309	1-215-474-00	METAL 160K 1%	1/6W
R199	1-249-417-11	CARBON 1K 5%	1/4W	R310	1-215-448-00	METAL 13K 1%	1/6W
R238	1-249-469-11	CARBON 100K 5%	1/4W	R311	1-249-408-11	CARBON 180 5%	1/4W
R239	1-247-723-11	CARBON 6.8K 5%	1/4W	R312	1-247-883-00	CARBON 150K 5%	1/4W
R240	1-247-720-11	CARBON 3.9K 5%	1/4W	R314	1-249-423-11	CARBON 3.3K 5%	1/4W
R241	1-247-719-11	CARBON 3.3K 5%	1/4W	R316	1-249-425-11	CARBON 4.7K 5%	1/4W
R242	1-247-152-00	CARBON 7.5K 5%	1/4W	R317	1-249-429-11	CARBON 10K 5%	1/4W
R243	1-249-469-11	CARBON 100K 5%	1/4W	R318	1-249-616-11	CARBON 470K 5%	1/4K
R244	1-247-747-11	CARBON 470 5%	1/2W	R319	△1-212-857-00	FUSIBLE 10 5%	1/4W F
R245	1-247-764-11	CARBON 10K 5%	1/2W	R320	1-249-465-11	CARBON 47K 5%	1/4W
R246	1-247-146-00	CARBON 4.3K 5%	1/4W	R401	1-249-428-11	CARBON 8.2K 5%	1/4W
R247	1-247-142-00	CARBON 3K 5%	1/4W	R402	1-249-417-11	CARBON 1K 5%	1/4W
R248	1-247-710-11	CARBON 560 5%	1/4W	R403	1-247-725-11	CARBON 10K 5%	1/4W
				R404	1-249-429-11	CARBON 10K 5%	1/4W
				R405	1-249-429-11	CARBON 10K 5%	1/4W

**Note:** The components identified by mark  or dotted line with mark  are critical for safety. Replace only with part number specified.

RECT.

Ref. No.	Part No.	Description	Remark			Ref. No.	Part No.	Description	Remark			
R406	1-249-417-11	CARBON	1K	5%	1/4W	R754	1-249-437-11	CARBON	47K	5%	1/4W	
R407	1-249-437-11	CARBON	47K	5%	1/4W	R755	1-249-421-11	CARBON	2. 2K	5%	1/4W	
R408	1-215-465-00	METAL	68K	1%	1/6W	R756	1-249-425-11	CARBON	4. 7K	5%	1/4W	
R409	1-215-474-00	METAL	160K	1%	1/6W	R757	1-249-437-11	CARBON	47K	5%	1/4W	
R410	1-215-448-00	METAL	13K	1%	1/6W	R758	1-249-422-11	CARBON	2. 7K	5%	1/4W	
R411	1-249-408-11	CARBON	180	5%	1/4W	R759	1-249-427-11	CARBON	6. 8K	5%	1/4W	
R412	1-247-883-00	CARBON	150K	5%	1/4W	R760	1-249-425-11	CARBON	4. 7K	5%	1/4W	
R414	1-249-423-11	CARBON	3. 3K	5%	1/4W	R761	1-249-437-11	CARBON	47K	5%	1/4W	
R416	1-249-425-11	CARBON	4. 7K	5%	1/4W	R762	1-249-421-11	CARBON	2. 2K	5%	1/4W	
R417	1-249-429-11	CARBON	10K	5%	1/4W	R763	1-249-441-11	CARBON	100K	5%	1/4W	
R418	1-249-616-11	CARBON	470K	5%	1/4W	R764	1-249-425-11	CARBON	4. 7K	5%	1/4W	
R419	△1-212-857-00	FUSIBLE	10	5%	1/4W	F	R765	1-249-437-11	CARBON	47K	5%	1/4W
R420	1-249-465-11	CARBON	47K	5%	1/4W	R766	1-249-437-11	CARBON	47K	5%	1/4W	
R531	1-249-438-11	CARBON	56K	5%	1/4W	R767	1-249-429-11	CARBON	10K	5%	1/4W	
R532	1-249-433-11	CARBON	22K	5%	1/4W	R768	1-249-437-11	CARBON	47K	5%	1/4W	
R533	1-249-421-11	CARBON	2. 2K	5%	1/4W	R769	1-249-437-11	CARBON	47K	5%	1/4W	
R537	1-249-417-11	CARBON	1K	5%	1/4W	R770	1-249-433-11	CARBON	22K	5%	1/4W	
R538	1-249-425-11	CARBON	4. 7K	5%	1/4W	R771	1-249-395-11	CARBON	15	5%	1/4W	
R539	1-249-437-11	CARBON	47K	5%	1/4W	R772	1-249-395-11	CARBON	15	5%	1/4W	
R540	1-249-433-11	CARBON	22K	5%	1/4W	R773	△1-219-136-11	FUSIBLE	0. 22	10%	1/4W	
R542	1-249-429-11	CARBON	10K	5%	1/4W	R774	△1-219-136-11	FUSIBLE	0. 22	10%	1/4W	
R543	1-249-424-11	CARBON	3. 9K	5%	1/4W	R775	△1-219-136-11	FUSIBLE	0. 22	10%	1/4W	
R544	1-249-418-11	CARBON	1. 2K	5%	1/4W	R776	1-249-413-11	CARBON	470	5%	1/4W	
R545	1-249-428-11	CARBON	8. 2K	5%	1/4W	R801	△1-249-482-11	CARBON	4. 7	5%	1/2W	
R546	1-249-429-11	CARBON	10K	5%	1/4W	R802	1-249-425-11	CARBON	4. 7K	5%	1/4W	
R547	1-249-405-11	CARBON	100	5%	1/4W	R803	1-249-425-11	CARBON	4. 7K	5%	1/4W	
R548	1-249-405-11	CARBON	100	5%	1/4W	R804	1-249-426-11	CARBON	5. 6K	5%	1/4W	
R549	1-249-405-11	CARBON	100	5%	1/4W	R805	1-247-856-00	CARBON	11K	5%	1/4W	
R550	1-249-405-11	CARBON	100	5%	1/4W	R806	1-249-425-11	CARBON	4. 7K	5%	1/4W	
R551	1-249-405-11	CARBON	100	5%	1/4W	R807	△1-249-482-11	CARBON	4. 7	5%	1/2W	
R552	1-249-405-11	CARBON	100	5%	1/4W	R808	1-249-425-11	CARBON	4. 7K	5%	1/4W	
R553	1-249-429-11	CARBON	10K	5%	1/4W	R809	1-249-425-11	CARBON	4. 7K	5%	1/4W	
R554	1-249-429-11	CARBON	10K	5%	1/4W	R810	1-249-426-11	CARBON	5. 6K	5%	1/4W	
R556	1-249-428-11	CARBON	8. 2K	5%	1/4W	R811	1-249-429-11	CARBON	10K	5%	1/4W	
R557	1-247-856-00	CARBON	11K	5%	1/4W	R812	1-249-425-11	CARBON	4. 7K	5%	1/4W	
R558	1-249-397-11	CARBON	22	5%	1/4W	R813	1-249-429-11	CARBON	10K	5%	1/4W	
R559	1-249-407-11	CARBON	150	5%	1/4W	R814	1-249-429-11	CARBON	10K	5%	1/4W	
R560	1-247-856-00	CARBON	11K	5%	1/4W	R815	1-249-429-11	CARBON	10K	5%	1/4W	
R561	1-249-428-11	CARBON	8. 2K	5%	1/4W	R816	1-249-429-11	CARBON	10K	5%	1/4W	
R562	1-249-432-11	CARBON	18K	5%	1/4W	R817	1-249-429-11	CARBON	10K	5%	1/4W	
R563	1-249-397-11	CARBON	22	5%	1/4W	R818	1-249-429-11	CARBON	10K	5%	1/4W	
R564	1-249-407-11	CARBON	150	5%	1/4W	R819	1-249-429-11	CARBON	10K	5%	1/4W	
R565	1-249-432-11	CARBON	18K	5%	1/4W	R820	1-249-429-11	CARBON	10K	5%	1/4W	
R566	1-247-887-00	CARBON	220K	5%	1/4W	R821	1-249-429-11	CARBON	10K	5%	1/4W	
R567	1-247-887-00	CARBON	220K	5%	1/4W	R822	1-249-429-11	CARBON	10K	5%	1/4W	
R568	1-249-407-11	CARBON	150	5%	1/4W	R823	1-249-429-11	CARBON	10K	5%	1/4W	
R569	1-249-422-11	CARBON	2. 7K	5%	1/4W	R824	1-249-405-11	CARBON	100	5%	1/4W	
R572	1-249-429-11	CARBON	10K	5%	1/4W	R825	1-249-405-11	CARBON	100	5%	1/4W	
R573	1-249-439-11	CARBON	68K	5%	1/4W	R826	1-249-405-11	CARBON	100	5%	1/4W	
R575	1-249-429-11	CARBON	10K	5%	1/4W	R827	1-249-405-11	CARBON	100	5%	1/4W	
R576	1-249-429-11	CARBON	10K	5%	1/4W	R828	1-249-405-11	CARBON	100	5%	1/4W	
R583	1-249-417-11	CARBON	1K	5%	1/4W	R829	1-249-405-11	CARBON	100	5%	1/4W	
R584	1-249-437-11	CARBON	47K	5%	1/4W	R830	1-249-405-11	CARBON	100	5%	1/4W	
R587	1-249-437-11	CARBON	47K	5%	1/4W	R831	1-249-405-11	CARBON	100	5%	1/4W	
R701	△1-212-861-11	FUSIBLE	15	5%	1/4W	F	R832	1-249-405-11	CARBON	100	5%	1/4W
R702	1-249-436-11	CARBON	39K	5%	1/4W	R833	1-249-405-11	CARBON	100	5%	1/4W	
R703	1-249-439-11	CARBON	68K	5%	1/4W	R834	1-249-405-11	CARBON	100	5%	1/4W	
R751	1-249-421-11	CARBON	2. 2K	5%	1/4W	R835	1-249-425-11	CARBON	4. 7K	5%	1/4W	
R752	1-249-425-11	CARBON	4. 7K	5%	1/4W	R836	1-249-417-11	CARBON	1K	5%	1/4W	
R753	1-249-437-11	CARBON	47K	5%	1/4W	R837	1-249-435-11	CARBON	33K	5%	1/4W	

Note: The components identified by mark △ or dotted line with mark △ are critical for safety. Replace only with part number specified.

**RECT.**

Ref. No.	Part No.	Description	Remark
R838	1-249-435-11	CARBON 33K 5% 1/4W	
R839	1-247-903-00	CARBON 1M 5% 1/4W	
R840	1-249-429-11	CARBON 10K 5% 1/4W	
R841	1-249-405-11	CARBON 100 5% 1/4W	
R842	1-249-405-11	CARBON 100 5% 1/4W	
R843	1-249-405-11	CARBON 100 5% 1/4W	
R844	1-249-405-11	CARBON 100 5% 1/4W	
R845	1-249-429-11	CARBON 10K 5% 1/4W	
R846	1-249-429-11	CARBON 10K 5% 1/4W	
R847	1-249-427-11	CARBON 6.8K 5% 1/4W	
R848	1-249-429-11	CARBON 10K 5% 1/4W	
R849	1-249-429-11	CARBON 10K 5% 1/4W	
R850	1-249-429-11	CARBON 10K 5% 1/4W	
R851	1-249-429-11	CARBON 10K 5% 1/4W	
R852	1-249-413-11	CARBON 470 5% 1/4W	
R853	1-249-412-11	CARBON 390 5% 1/4W	
R854	1-249-410-11	CARBON 270 5% 1/4W	
R855	1-249-436-11	CARBON 39K 5% 1/4W	
R856	1-249-436-11	CARBON 39K 5% 1/4W	
R857	1-249-405-11	CARBON 100 5% 1/4W	
R858	1-249-405-11	CARBON 100 5% 1/4W	
R859	1-249-405-11	CARBON 100 5% 1/4W	
R860	1-249-405-11	CARBON 100 5% 1/4W	
R861	1-249-429-11	CARBON 10K 5% 1/4W	
R862	1-249-429-11	CARBON 10K 5% 1/4W	
R863	1-249-441-11	CARBON 100K 5% 1/4W	
R864	1-249-441-11	CARBON 100K 5% 1/4W	
R865	1-249-441-11	CARBON 100K 5% 1/4W	
R866	1-249-441-11	CARBON 100K 5% 1/4W	
R867	1-249-441-11	CARBON 100K 5% 1/4W	
R868	1-249-441-11	CARBON 100K 5% 1/4W	
		< VARIABLE RESISTOR >	
RV102	1-224-251-XX	RES, ADJ, METAL GLAZE 4.7K	
RV103	1-238-011-11	RES, ADJ, CARBON 470	
RV104	1-238-597-11	RES, ADJ, CARBON 1K	
RV105	1-238-600-11	RES, ADJ, CARBON 10K	
RV106	1-238-600-11	RES, ADJ, CARBON 10K	
RV107	1-238-600-11	RES, ADJ, CARBON 10K	
RV108	1-238-601-11	RES, ADJ, CARBON 22K	
RV202	1-224-251-XX	RES, ADJ, METAL GLAZE 4.7K	
RV203	1-238-011-11	RES, ADJ, CARBON 470	
RV204	1-238-597-11	RES, ADJ, CARBON 1K	
RV205	1-238-600-11	RES, ADJ, CARBON 10K	
RV206	1-238-600-11	RES, ADJ, CARBON 10K	
RV207	1-238-600-11	RES, ADJ, CARBON 10K	
RV208	1-238-601-11	RES, ADJ, CARBON 22K	
RV504	1-241-231-11	RES, ADJ, CARBON 100	
RV505	1-241-231-11	RES, ADJ, CARBON 100	
RV801	1-238-598-11	RES, ADJ, CARBON 2.2K	
		< RELAY >	
RY502	1-515-803-11	RELAY	
RY503	1-515-614-11	RELAY	
		< TRANSFORMER >	
T101	1-433-361-11	TRANSFORMER, BIAS OSCILLATION	
T201	1-433-361-11	TRANSFORMER, BIAS OSCILLATION	

Ref. No.	Part No.	Description	Remark
		< THERMISTOR >	
TH501	1-202-855-00	THERMISTOR (POSITIVE)	
		< TEST PIN >	
TP1	* 1-535-115-00	TERMINAL	
TP801	* 1-564-337-00	PIN, CONNECTOR 3P	
		< VIBRATOR >	
X801	1-577-358-21	VIBRATOR, CERAMIC	
*****			
		MISCELLANEOUS	
		*****	
112	1-559-297-32	CORD, POWER (K333ESL:E)	
112	1-574-383-11	CORD, POWER (K970ES)	
119	1-569-007-11	ADAPTER, CONVERSION 2P (K333ESL:E)	
196	* 1-608-268-00	PC BOARD, ERASE HEAD	
257	1-632-779-11	PC BOARD, FG	
F701	1-532-286-00	FUSE, TIME-LAG (2.5A)	
F702	1-532-286-00	FUSE, TIME-LAG (2.5A)	
HE501	1-543-358-11	HEAD, MAGNETIC (ERASE)	
HRP501	1-543-684-11	HEAD, MAGNETIC (REC/PB)	
M1001	X-3356-638-1	MOTOR (REEL R) ASSY	
M1002	X-3356-604-1	MOTOR (ASSIST) ASSY	
S1001	1-466-238-11	ENCODER, ROTARY	
S702	1-157-009-11	SELECTOR, VOLTAGE	
T701	△1-450-451-11	TRANSFORMER, POWER (K970ES)	
T701	△1-450-453-11	TRANSFORMER, POWER (K333ESL:E)	
*****			
		ACCESSORY & PACKING MATERIAL	
		*****	
	1-465-314-11	REMOTE COMMANDER (K333ESL:E)	
	2-181-754-01	COVER, BATTERY (K333ESL:E)	
	1-558-271-11	CORD, CONNECTION	
	* 3-350-465-01	CUSHION	
	* 3-367-121-01	INDIVIDUAL CARTON (K970ES)	
	* 3-367-122-01	INDIVIDUAL CARTON (K333ESL:E)	
	3-367-548-11	LABEL, MODEL NUMBER (AE)	
	3-752-611-11	MANUAL, INSTRUCTION (English, French, Spanish, Portuguese)	
	3-752-611-41	MANUAL, INSTRUCTION (K970ES: German, Dutch, Swedish, Italian)	
	3-793-481-13	INSTRUCTION	
	4-847-802-00	SCREW	
*****			

<u>Ref. No.</u>	<u>Part No.</u>	<u>Description</u>	<u>Remark</u>
-----------------	-----------------	--------------------	---------------

**HARDWARE LIST**

\*\*\*\*\*

# 1	7-682-547-04	SCREW +BVTT 3X6 (S)	
# 2	7-682-562-09	SCREW +BVTT 4X10 (S)	
# 3	7-682-548-04	SCREW, TIGHT, S	
# 4	7-685-870-01	SCREW +BVTT 3X5 (S)	
# 5	7-682-547-09	SCREW +BV 3X6, S TIGHT	
# 6	7-685-645-79	SCREW +BVTP 3X6 TYPE2 SLIT	
# 7	7-682-549-04	SCREW +BVTT 3X10 (S)	
# 8	7-682-147-15	SCREW, TR	
# 9	7-685-647-79	SCREW +BVTP 3X10 TYPE2 N-S	
# 10	7-682-560-04	SCREW +BVTT 4X6 (S) (K333ESL:E)	
# 11	7-621-772-10	SCREW +B 2X4	
# 12	7-621-772-70	SCREW +B 2X14	
# 13	7-621-775-10	SCREW +B 2.6X4	
# 14	7-622-205-05	NUT M2 TYPE2	
# 15	7-628-253-00	SCREW +PS 2X4	
# 16	7-628-254-10	SCREW +PS 2.6X6	
# 17	7-671-154-01	STENLESS BALL	
# 18	7-682-648-09	SCREW +PS 3X8	
# 19	7-685-133-19	SCREW +BTP 2.6X6 TYPE2 N-S	
# 20	7-621-255-20	SCREW +BVTT 2X4 (S)	
# 21	7-621-255-35	SCREW +BVTT 2X5 (S)	
# 22	7-685-870-01	SCREW +BVTT 3X5 (S)	



# TC-K333ESL/K970ES

## SONY<sup>®</sup> SERVICE MANUAL

*AEP Model*  
TC-K970ES

*E Model*  
TC-K333ESL

### SUPPLEMENT-1

File this Supplement with the Service Manual.

Subject : The gold type of TC-K970ES has been added.

- The gold type is the same as black type except for the parts as shown in the table.
- Use this manual for servicing the gold-type set.
- Items marked "\*" are not stocked since they are seldom required for routine service. Some delay should be anticipated when ordering these items.

page	BLACK TYPE		GOLD TYPE	
	Ref. No	Part. No	Part. No	Description
43	2	3-364-438-21	3-364-438-31	WINDOW, CASSETTE
	4	X-3362-818-1	X-3363-490-1	KNOB (DIA, 12) ASSY (B), SQUARE
	5	3-364-475-31	3-364-475-41	PANEL, FRONT
	7	4-908-848-01	4-908-848-21	EMBLEM, SONY
	8	4-908-044-11	4-908-044-21	ESCUTCHEON, POWER KNOB
	9	3-364-444-01	4-908-444-11	ESCUTCHEON (L)
	10	3-364-442-11	3-364-442-21	WINDOW, COUNTER
	12	3-364-443-01	3-364-443-11	WINDOW, METER
	13	3-364-447-01	3-364-447-11	ESCUTCHEON (R)
	15	X-3304-959-1	X-3363-492-2	PANEL (LEFT) ASSY, SIDE
	16	4-923-474-01	4-928-025-41	RING, ORNAMENTAL
	17	3-704-366-01	3-704-366-11	SCREW (CASE) (M3 x 8)
	18	*3-350-489-11	*3-350-489-21	CASE
19	X-3304-960-1	X-3363-493-2	PANEL (RIGHT) ASSY, SIDE	
21	X-3304-944-1	X-3363-489-1	FOOT ASSY	
44	51	*3-364-474-01	*3-364-474-12	PANEL (BASE)
	52	4-922-518-11	4-922-518-62	KNOB (TIMER)
	53	4-908-046-01	4-908-046-81	KNOB, SQUARE
	64	X-3362-327-1	X-3363-491-1	BUTTON ASSY
	70	3-364-441-01	3-364-441-11	BUTTON
	71	3-364-440-01	3-364-440-11	KNOB (L)
72	3-364-439-01	3-364-439-11	KNOB (R)	
45	116	*3-350-482-21	*3-350-482-41	PANEL BACK (K970ES)

# TC-K333ESL/K970ES

## SONY<sup>®</sup> SERVICE MANUAL

AEP Model  
TC-K970ES

E Model  
TC-K333ESL

### CORRECTION-1

Correct your service manual as shown below.

 : indicates corrected portion.

Page	INCORRECT	CORRECT												
58	<table><thead><tr><th><u>Ref No.</u></th><th><u>Part No.</u></th><th><u>Description</u></th></tr></thead><tbody><tr><td>RY503</td><td>1-515-614-11</td><td>RELAY</td></tr></tbody></table>	<u>Ref No.</u>	<u>Part No.</u>	<u>Description</u>	RY503	1-515-614-11	RELAY	<table><thead><tr><th><u>Ref No.</u></th><th><u>Part No.</u></th><th><u>Description</u></th></tr></thead><tbody><tr><td>RY503</td><td>1-515-803-11</td><td>RELAY</td></tr></tbody></table> 	<u>Ref No.</u>	<u>Part No.</u>	<u>Description</u>	RY503	1-515-803-11	RELAY
<u>Ref No.</u>	<u>Part No.</u>	<u>Description</u>												
RY503	1-515-614-11	RELAY												
<u>Ref No.</u>	<u>Part No.</u>	<u>Description</u>												
RY503	1-515-803-11	RELAY												