

TC-K790ES

SERVICE MANUAL

AEP Model



Dolby noise reduction and HX Pro headroom extension manufactured under license from Dolby Laboratories Licensing Corporation. HX Pro originated by Bang & Olufsen. "DOLBY", the double-D symbol $\square\square$ and "HX PRO" are trademarks of Dolby Laboratories Licensing Corporation.

Model Name Using Similar Mecanism	TC-K770ES
Tape Transport Mechanism Type	TCM-200D9

SPECIFICATIONS

Recording system 4-track 2-channel stereo
 Fast winding time Approx. 90 sec. (with Sony C-60 cassette)
 Bias AC bias
 Heads Erasing head \times 1 (S&F head)
 Recording head \times 1 (Permalloy head)
 Playback head \times 1 (Permalloy head)
 Motors Capstan motor \times 1 (direct drive linear torque BSL motor)
 Reel motor \times 1 (DC motor)

Signal-to-noise ratio (at peak level)

Cassette (Dolby NR OFF)	Type IV (Sony Metal-S)	Type II (Sony UX-S)	Type I (Sony HF-S)
	61 dB	59 dB	57 dB

Measured at peak level weithted without NR. The S/N is improved by about 15 dB at 500 Hz and by about 20 dB about 1 kHz with Dolby-C NR on, and by 5 dB at 1 kHz and by 10 dB about 5 kHz with DolbyB-NR on.

Harmonic distortion 1.5% (with Sony Metal-S 250 nWb/m, 315Hz, 3rd H.D.)

Frequency response (Dolby NR OFF)

Type IV cassette (Sony Metal-S)	20 - 21,000 Hz (\pm 3 dB, IEC) 20 - 16,000 Hz [\pm 3 dB (-4 dB recording)]
Type II cassette (Sony UX-S)	20 - 19,000 Hz (\pm 3 dB, IEC)
Type I cassette (Sony HF-S)	20 - 17,000 Hz (\pm 3 dB, IEC)

Wow and flutter \pm 0.05% W.Peak (IEC)
 0.025% W.RMS (NAB)
 \pm 0.07% W.Peak (DIN)

Inputs

Line inputs (phono jacks)	Sensitivity	0.16V
	Input impedance	47 k ohms
CD DIRECT INPUT	Input impedance	47 k ohms

Outputs

Line outputs (phono jacks)	Rated output level	0.5 V at a load impedance of 47 k ohms
	Load impedance	Over 10 k ohms
Headphones (stereo phone jack)	Output level	0 - 3 mW at a load impedance of 32 ohms

General

Power requirements 220 - 230 V AC, (or 240 V AC adjustable by Sony personnel), 50/60 Hz
 23 W
 Power consumption
 Dimensions Approx. 430 \times 135 \times 350 mm (w/h/d) (17 \times 5 $\frac{1}{8}$ \times 13 $\frac{7}{8}$ inches) including projecting parts and controls
 Weight Approx. 6.9 kg (15 lbs 4 oz)
 Supplied accessories Audio connecting cords (2)



Design and specifications are subject to change without notice.

STEREO CASSETTE DECK
SONY[®]

TABLE OF CONTENTS

<u>Section</u>	<u>Title</u>	<u>Page</u>
SPECIFICATIONS	1
1. GENERAL	3
2. DISASSEMBLY	8
3. ADJUSTMENTS		
3-1. Mechanical Adjustments	10
3-2. Electrical Adjustments	13
4. DIAGRAMS		
4-1. Description on IC	18
4-2. Circuit Boards Location	21
4-3. IC Block Diagrams	22
4-4. Block Diagrams	23
4-5. Semiconductor Lead Layouts	26
4-6. Printed Wiring Boards - Main Section -	27
4-7. Schematic Diagram - Main Section -	31
4-8. Schematic Diagram - Panel Section -	36
4-9. Printed Wiring Boards - Panel Section -	39
5. EXPLODED VIEWS		
5-1. Overall Section	41
5-2. Panel Section	42
5-3. Mechanism Section-1 (TCM-200D9)	43
5-4. Mechanism Section-2 (TCM-200D9)	44
6. ELECTRICAL PARTS LIST	45

SAFETY-RELATED COMPONENT WARNING!!

COMPONENTS IDENTIFIED BY MARK  OR DOTTED LINE WITH MARK  ON THE SCHEMATIC DIAGRAMS AND IN THE PARTS LIST ARE CRITICAL TO SAFE OPERATION. REPLACE THESE COMPONENTS WITH SONY PARTS WHOSE PART NUMBERS APPEAR AS SHOWN IN THIS MANUAL OR IN SUPPLEMENTS PUBLISHED BY SONY.

SECTION 1
GENERAL

This section is extracted from instruction manual.

Identifying the Parts

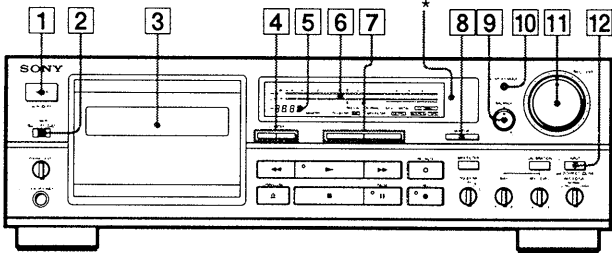

Front Panel

For details, refer to the page number indicated in parenthesis .

- 1 POWER switch
- 2 TIMER switch (50)
- 3 Cassette holder
- 4 Counter buttons
RESET button (26)
MEMORY button (24, 26)
- 5 LINEAR COUNTER (26)
- 6 PEAK PROGRAM METER (32)
- 7 AMS (Automatic Music Sensor) buttons (22)
- 8 MONITOR button (34)
- 9 BALANCE control (28)
- 10 DISPLAY MODE button (18)
- 11 REC (recording) LEVEL control (28, 32)
- 12 INPUT button (28)

* Remote control sensor
You can remotely control this cassette deck with:

- A remote commander that came with a Sony amplifier or receiver if it has the mark and cassette deck control capability.
- An optional Sony remote commander with the mark and cassette deck control capability.

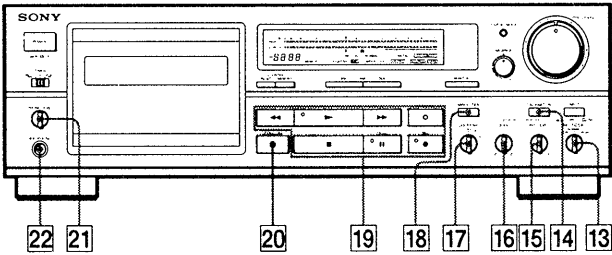

- 13 REC EQ CAL (recording equalizing calibration) switch (LOW, NORMAL, HIGH) (42)
- 14 CALIBRATION button (40)
- 15 REC (recording) LEVEL control for calibration (36, 40)
- 16 BIAS control (36, 40)
- 17 DOLBY NR (noise reduction) switch (18, 28)
- 18 MPX FILTER button (32)
- 19 Tape operation buttons and indicators
 - ◀ (rewind) button
 - (stop) button
 - ▶ (play) button and indicator
 - ▶▶ (fast-forward) button
 - REC (recording) button and indicator
 - || PAUSE button and indicator
 - REC MUTE (record muting) button (48)
- 20 ▲ OPEN/CLOSE button
- 21 PHONE (headphones) LEVEL control
- 22 HEADPHONES jack (stereo phone jack) (20)

Recording

Recording FM Broadcasts with the Dolby NR System

When recording FM broadcasts with the Dolby NR system, set the MPX FILTER button to ON (the "FILTER" indicator appears).

The MPX filter eliminates remnants of the 19-kHz stereo carrier and 38-kHz subcarrier signals which may impair the operation of the DOLBY NR system. Be sure that the Dolby NR switch is turned on since the MPX filter will not function otherwise. During recording with the Dolby NR system, use this switch only if the tuner is not equipped with its own MPX filter or the equipped filter does not function effectively.

Adjusting the Recording Level

The optimum recording level, which differs according to the tape type, is indicated on the PEAK PROGRAM METER for each tape type. Adjust the REC LEVEL control as high as possible without exceeding the recommended range for the tape type being used.

PEAK PROGRAM METER recording by tape type

Fig. A shows the recommended maximum PEAK PROGRAM METER readings.
 a) for Type I (normal) or Type II (CrO₂) tape
 b) for Type IV (metal) tape

Tips on recording level adjustment

- If the recording level setting is too high, the recording will be distorted; if it is too low, the tape will produce a hissing sound. Therefore, the recording level should be set as high as possible without causing distortion.
- If the program source to be recorded has many high frequency signals, set the level to a relatively low position.

A

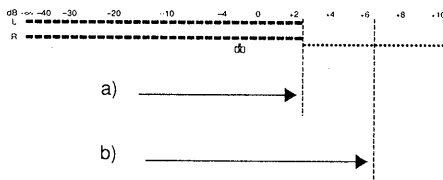

Monitoring the Recorded Sound

As this unit has three separate heads for recording, playback and erasure, you can check the quality of a recorded sound by comparing it with the input source signal.

To listen to the input source signal, set the MONITOR button to SOURCE. (Fig. A)

To listen to the sound recorded on the tape, set the MONITOR button to TAPE. (Fig. B)

Fig. A and B show the MONITOR button setting and their respective signal flow.
 a) Band
 b) Recording head
 c) Playback head

Comparing the recorded sound with the sound source

While recording, use this monitoring function to check that there is no distortion due to excessive level settings or sound degradation due to head contamination.

A

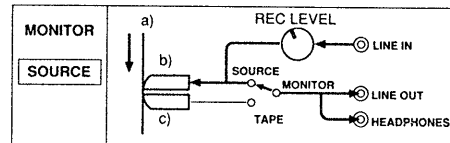

B

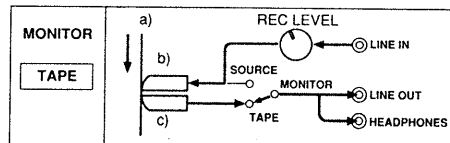

Making an Optimum Recording

Bias and Recording Level Calibration

There are many different types of cassettes on the market, each with varying magnetic properties. Although your unit is equipped with the ATS (Automatic Tape Selection) system which sets the appropriate equalization characteristics and bias current for each tape type, an additional calibration adjustment can often produce even better results. Use the bias current and recording level calibration function to obtain the optimum recording conditions for your tape.

Fig. **A** shows the BIAS control and REC (recording) LEVEL control for calibration.
 a) Adjusts bias current within $\pm 20\%$
 b) Adjusts recording level within ± 3 dB

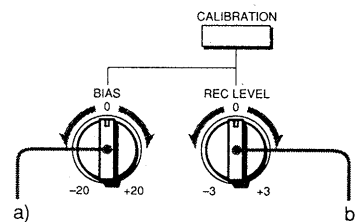

Bias calibration

Choosing the optimum bias current for a tape ensures minimum distortion and flat frequency response. Lowering the bias current boosts high-frequency response, but also results in higher distortion. Raising the bias, on the other hand, reduces distortion, but also dampens high-frequency response. Optimum bias is thus obtained when the bias current and high-frequency response are well balanced.

Fig. **B** shows the BIAS control and a high-frequency response balance chart.

- a) High-frequency response rises
- b) High-frequency response drops
- c) Output (level in dB)
- d) Frequency in Hz
- e) Bias reduced (-)
- f) Bias increased (+)

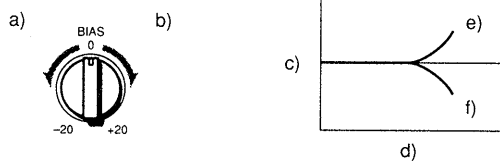

(Continued on next page.)

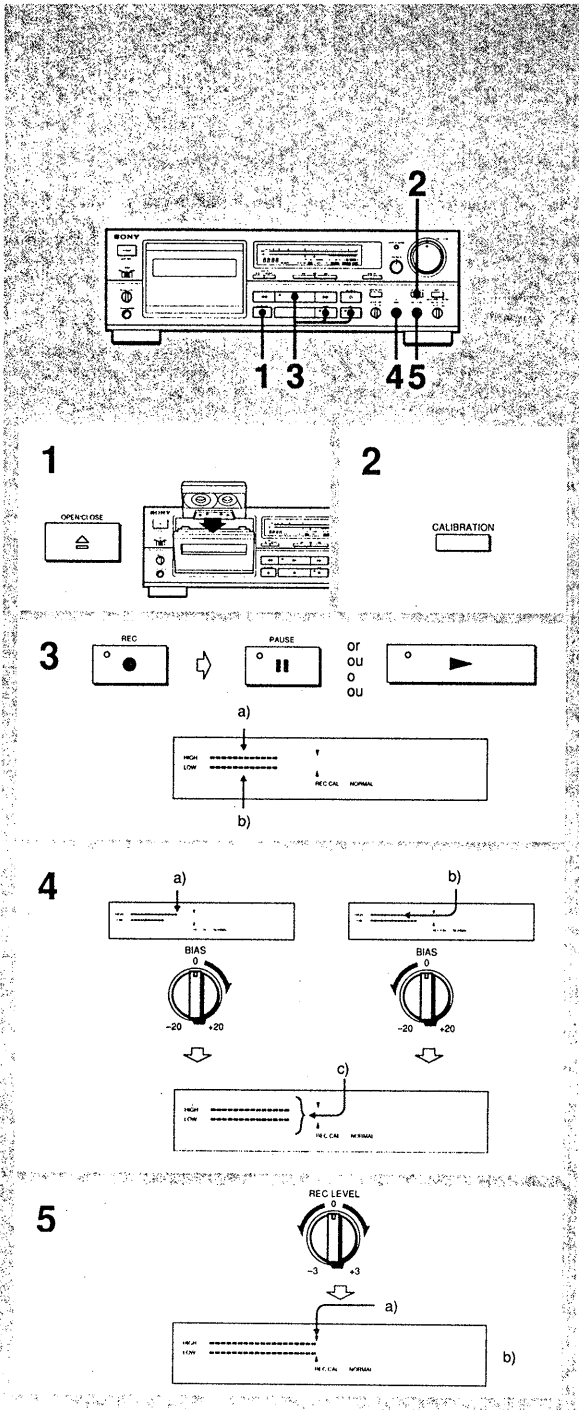

Making an Optimum Recording

- 1 Insert the cassette to be used for recording.
- 2 Press CALIBRATION.
- 3 Press ●, then II or ► to activate the recording test tone.

- a) Playback level for an 8-kHz signal
- b) Playback level for a 400-Hz signal

Note

- The sound cannot be monitored during the calibration operation.
- It takes 2 to 3 seconds for the test tone level to stabilize.

- 4 Adjust BIAS until both meters indicate equal playback levels.

- a) A high reading on the upper meter indicates a low bias current.
- b) A low reading on the upper meter indicates a high bias current.
- c) An equal reading on both meters indicates the optimum bias current condition.

- 5 Adjust REC LEVEL CALIBRATION until both meters reach the recommended level (REC CAL).

- a) Recommended level
- b) The bias current is now adjusted to the optimum level and the tape sensitivity compensation has been set. Press ■, then set CALIBRATION to OFF. Rewind the tape and start the actual recording.

Recording

Recording Equalization Calibration

Although bias current and equalization are automatically set by the Automatic Tape Selection (ATS) function for the tape being used, you can use the REC EQ CAL switch to change the recording characteristics according to the nature of the source material or to compensate for the particular characteristics of the tape.

Fig. A shows the REC EQ CAL switch.

- a) To emphasize higher frequencies in recordings
- b) For normal recordings
- c) To dampen higher frequencies in recordings

Bias Calibration Recording

Use the REC EQ CAL switch in conjunction with the BIAS control to modify bands of sound and record according to the tape's characteristics.

When recording music which has strong middle and low frequencies

Set the bias at flat with the REC EQ CAL switch set in the HIGH position to increase the bias current.

Adjust the BIAS control so that the HIGH and LOW meters indicate equal readings.

When recording music which has strong high frequencies

Set the bias at flat with the REC EQ CAL switch set in the LOW position to decrease the bias current.

Adjust the BIAS control so that the HIGH and LOW meters indicate equal readings.

Note

With metal tape, because the amount of frequency characteristic modulation is not in proportion to that of the bias, the optimum bias current may not be obtained using the methods above.

Another use of the REC EQ CAL switch

When using special tapes, adjusting the BIAS control with the REC EQ CAL switch set in the NORMAL position may not result in equal readings on the HIGH and LOW meters. If this occurs, adjust the BIAS control after setting the REC EQ CAL switch to HIGH or LOW.

A

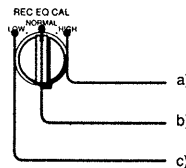

What is the Dolby HX PRO System?

The Dolby HX PRO system provides improved linearity in high-range frequency response during recording. Tapes recorded with this system retain the same high quality even when played back on other tape decks.

As shown in Fig. A, characteristics such as output level and distortion differ widely according to the bias (high-frequency) current.

Fig. A

- a) High
- b) Distortion output
- c) 315 Hz
- d) 6.3 kHz
- e) 10 kHz
- f) 315 Hz distortion
- g) Bias current
- h) High
- i) Established bias current

In conventional systems (see Fig. B), the bias current is susceptible to variations in certain recording signals which may cause fluctuations in frequency response, distortion, or other unwanted characteristics.

Fig. B

- a) High
- b) Output
- c) Fluctuation
- d) Frequency
- e) High

With the Dolby HX PRO system, the effective bias amount added to the bias current is controlled in millisecond units to greatly reduce distortion, improving linearity in high-range response and ensuring high-intensity recording with minimal distortion and noise.

A

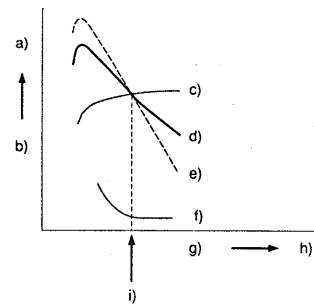

B

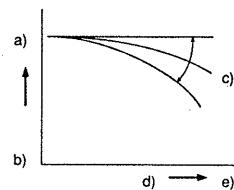

SECTION 2 DISASSEMBLY

• If the parts are marked with the numbers ❶, etc., remove them in the order of the number.

Cassette Holder

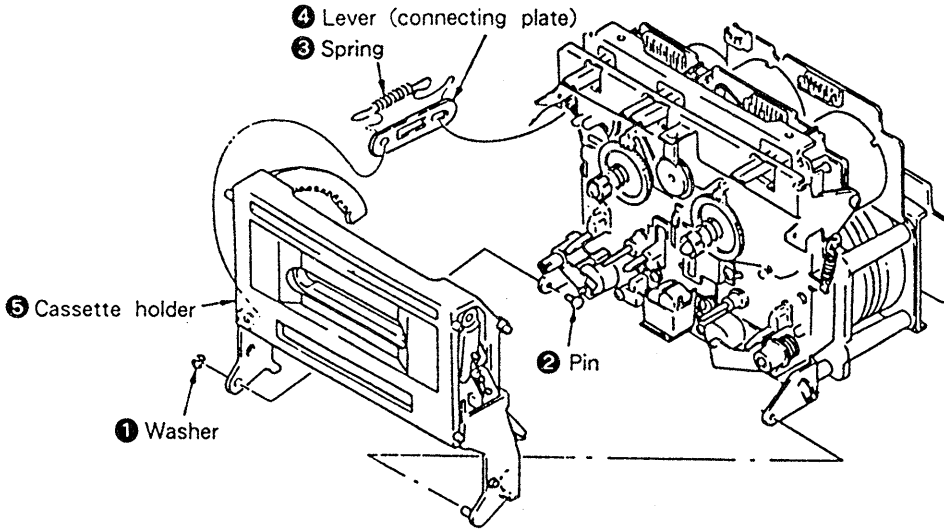

Ornamental Plate

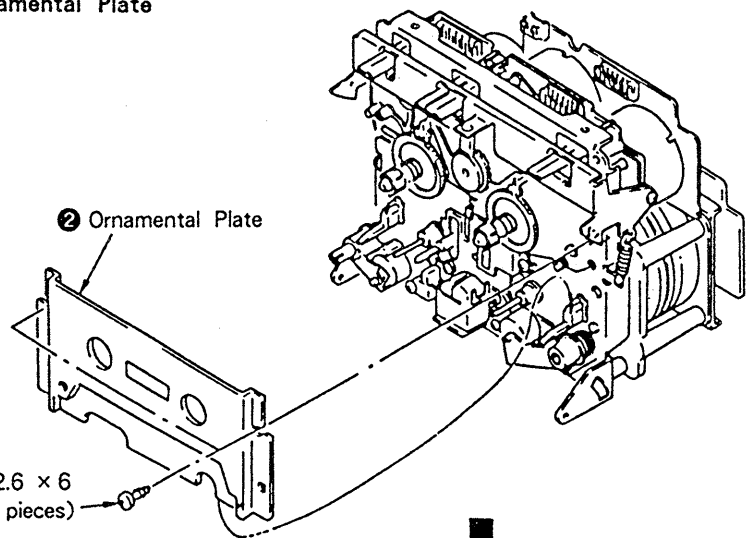

Pinch Lever/Lever FR

- ❶ - ❹ : Pinch lever S
- ❶ and ❷ : Pinch lever T
- ⚠ and ⚠ : Lever FR

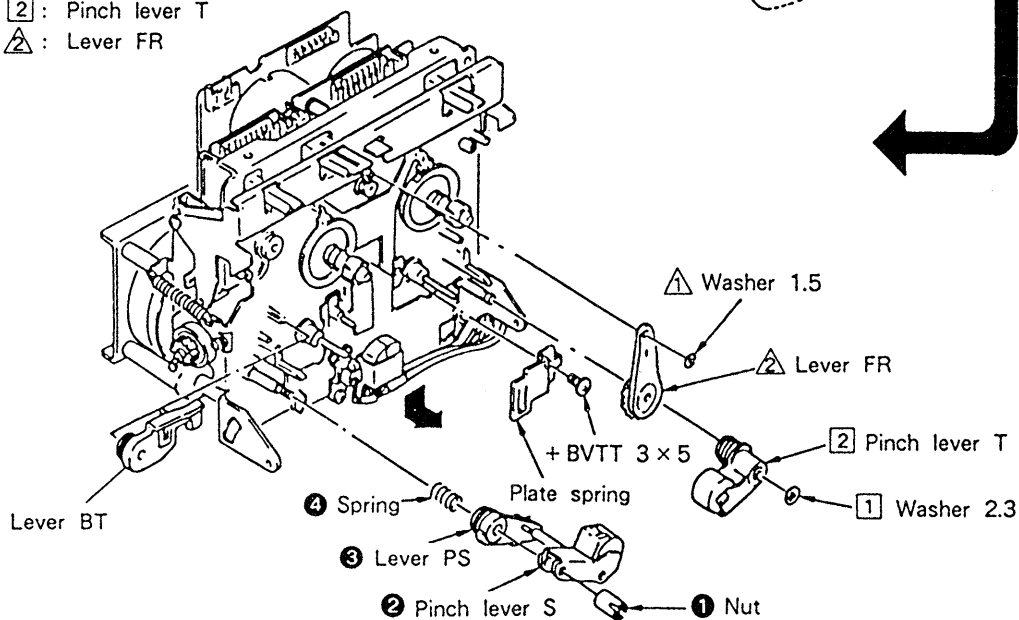

Comparator Board/Capstan Board/Flywheel/FG Board

△ and ▽ : Comparator board

① - ④ : Capstan board

① - ③ : FG board (after removing 1 and 2)

Note: To remove the above parts with the base (D1) assembly, remove the four screws marked with ★.

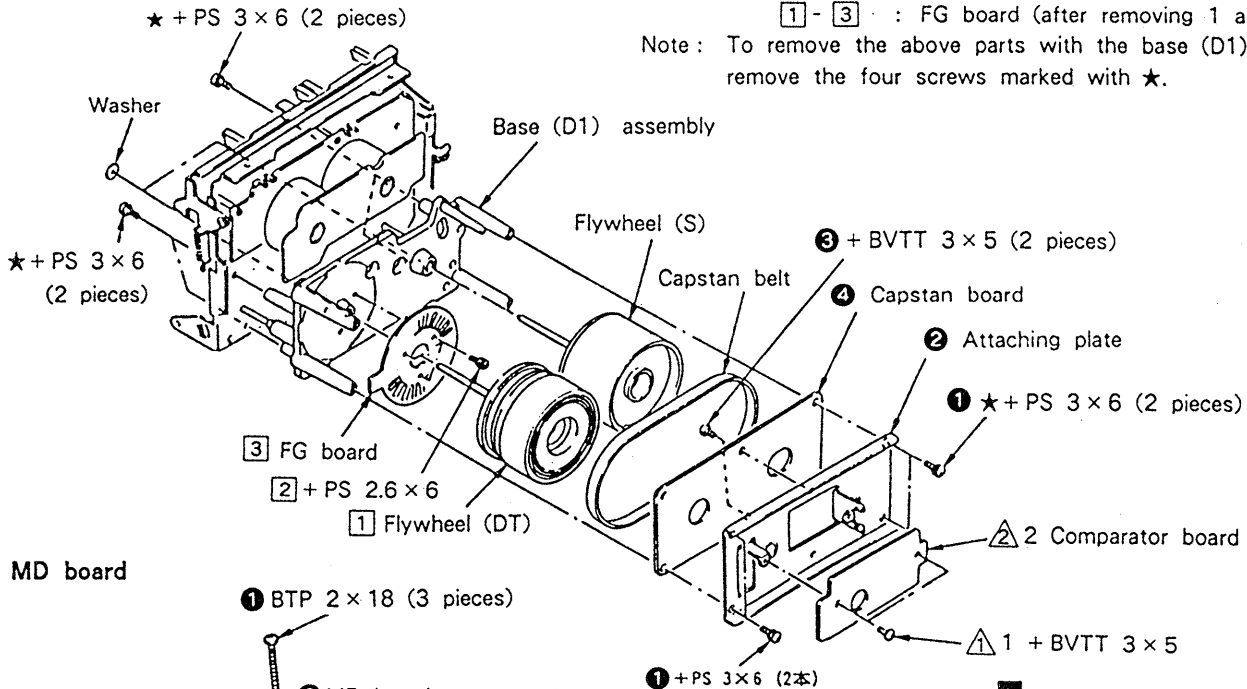

MD board

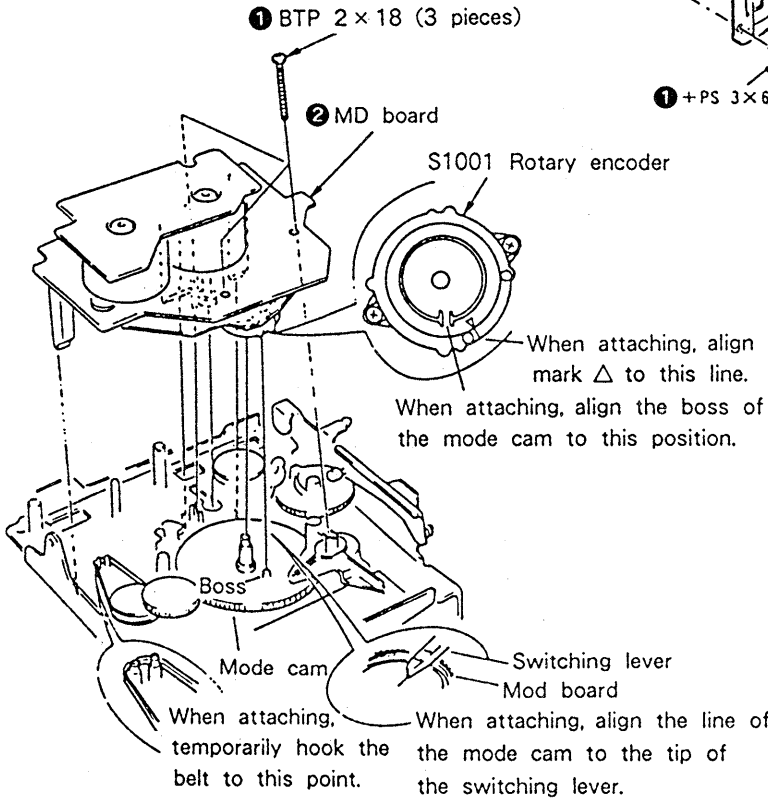

Reel Motor Board

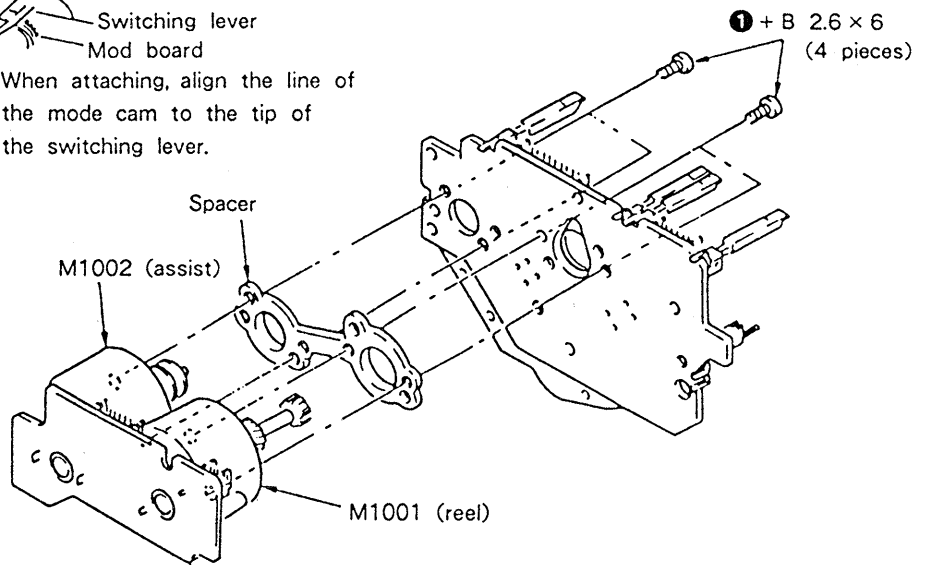

SECTION 3 ADJUSTMENTS

3-1. MECHANICAL ADJUSTMENTS

PRECAUTION

1. Clean the following parts with a denatured-alcohol-moistened swab :

record/playback head	pinch roller
erase head	rubber belts
capstan	idlers
2. Demagnetize the record/playback and erase head with a head demagnetizer.
3. Do not use a magnetized screwdriver for the adjustments.
4. After the adjustments, apply suitable locking compound to the parts adjusted.
5. The adjustments should be performed with the rated power supply voltage unless otherwise noted.

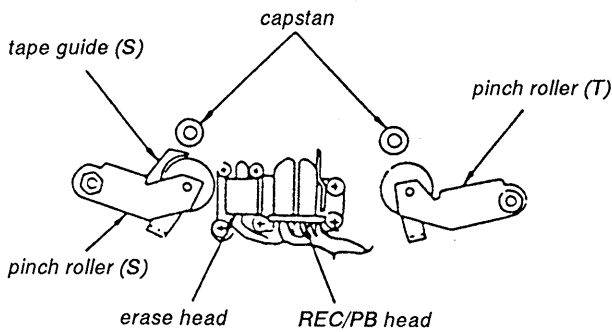
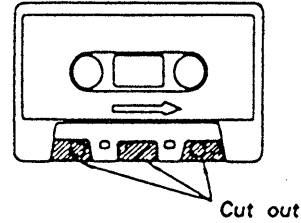

2. Phillips screwdriver (medium-size) :
For the head adjustment screws
- Blade-type screwdriver (large-size) :
For the supply pinch roller adjustment screws
3. Pen light
4. WS-48B (3 kHz, 0 dB)
5. P-4-A100 (10 kHz, -10 dB)

Definition of Terms : The figures are of a record/playback head.

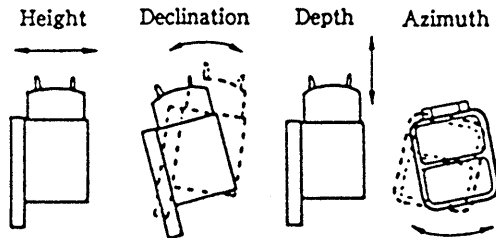

Tape Path Adjustment

• Refer to Adjustment Position on page 12.

Note : When using the adjustment methods for other than replacement reasons, please do not tamper unnecessarily with the adjustment screws or the erasehead because either the supply pinch roller guide or the record/playback head will be made the standard tape paths. Moreover, when it is necessary to adjust and replace two or more of any of the heads and/or pinch rollers, replace them one by one, completely taking out the first tape path, and then replacing the second one.

Preparation :

1. Mirror cassette CQ009C 8-909-708-01
(or CQ012C 8-909-708-02)

If one does not have this, cut out the sections of a 120-minute cassette shell as indicated below and use that cassette.

Adjustment Method :

Supply Pinch Roller

Note : Only perform this adjustment when the supply pinch roller is to be replaced.

1. Insert the mirror cassette and put the unit in record/playback mode.
2. Check to see whether the tape is curling at the record/playback head guide or the pinch roller guide.
If it is curling, remove the curl by adjusting the \odot tape curl adjustment screw. Then, check that the tape is running past the middle of the erasehead.

Record/playback Head

Note : Only perform this adjustment when the record /playback head is to be replaced.

1. Insert the mirror cassette and put the unit in record/playback mode.
2. (Height Adjustment) Check to see if the tape is curling at the tape guide of the head. If it is curling, tighten screws A , B , and C , respectively by the same angle, moving the head so that it

remains at the same angle throughout the procedure. If it curls on the bottom side of the mirror cassette (actually the inner side), tighten all the screws equally; but loosen them if the tape begins to curl on the top side (outer side).

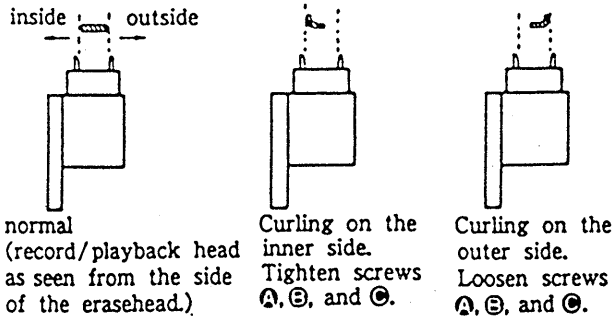

3. **(Declination Adjustment)** While in the record/playback position, set the back tension to 0 (wind the supply reel with something thin like a pencil in a counterclockwise direction) and make sure there is no curling or shifting (shifting up/shifting down) at the guide of the record/playback head.

Because shifting can only occur due to a difference in the width of the tape and that of the tape guides (curling will otherwise occur), it is necessary to pay close attention since it can be easily overlooked. When there is a shift, tighten screws B and C equally and change the declination of the head. If the tape is shifting up, tighten the screws, and if it is shifting down, loosen them.

4. Repeat the adjustments in steps 2 and 3 and fine adjust the height and the declination.

5. **(Preliminary Azimuth Adjustment)** After demagnetizing and cleaning the adjustment head, play back WS-48B (3 kHz, 0 dB). Turn screw D so that the reading on the level meter of the unit or that of the level meter connected to LINE OUT is maximized. If the screw is turned at least half a revolution, repeat the adjustments from step 1.

6. **(Tape Path Check)** Connect the oscilloscope to LINE OUT and play back P-4-A100 (10 kHz, -10 dB) to display a resurge waveform. After 20 seconds of record/playback (after the tension within the loop has been increased sufficiently), make sure the variation in the resurge is within ± 90 degrees (within ± 45 degrees is desired). If the variation is greater than this, it is because the declination and/or the height adjustment is not perfect. Repeat the adjustments from step 1.

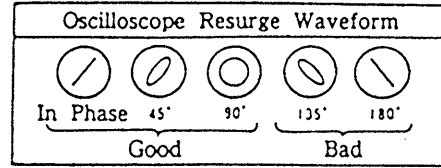
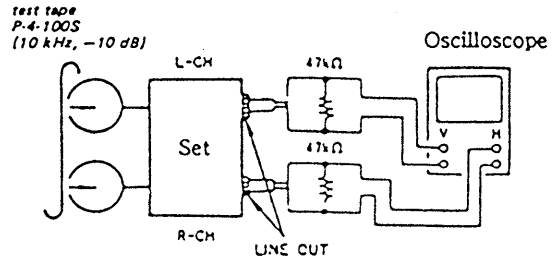

Erasehead

Note: Only perform this adjustment when the erasehead is to be replaced.

1. Insert the mirror cassette and put the unit in record/playback mode.
2. **(Azimuth Adjustment)** Adjust the azimuth of the erasehead by adjusting screws B and C so that the tape runs as evenly as possible.

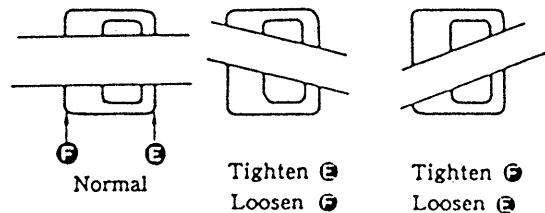

(The erasehead as seen when erasing the mirror cassette.)

3. **(Height adjustment)** Turn screws D, B, and C all by the same angle so that the portions of the erasehead visible at top and bottom are nearly of equal width. If the width at the top is greater, tighten the screws; if the width at the bottom is greater, loosen the screws.

Erasehead (The erasehead as seen through the mirror cassette.)

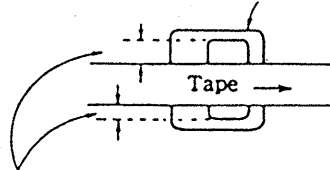

Make these the same width.

4. (Declination Adjustment) Leaving it in the playback position, put the back tension to 0 and make certain the erasehead part and supply pinch roller guide part do not shift. If there is a shift, turn the screw ⑤ and change the declination. Looking at it using the mirror cassette, if the tape shifts up, tighten the screw, and if it shifts down, loosen the screw.
5. Repeat the adjustments beginning with step 2 and fine adjust the height and declination. And make sure the tape does not curl up on the pinch roller guide or the guide part of the record/playback head.
6. (Depth Adjustment) In order to make the entire head play the tape smoothly, and to make sure the depth of the erasehead is neither too shallow nor too deep, loosen screw ⑥ a bit.

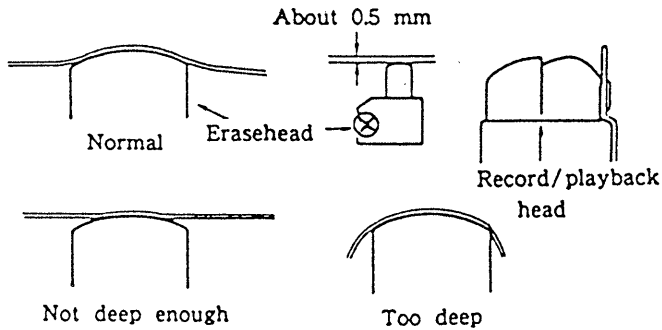

Check

1. Check to make sure that there are no curls or shifts throughout the whole tape path and that the tape runs smoothly.
2. Reapply the locking compound to the adjusted screws. (The locking compound should only be applied to screw ⑥ after the azimuth has been adjusted.)

Adjustment Position : As seen from the cassette, side (top) and MD as seen head on (bottom).

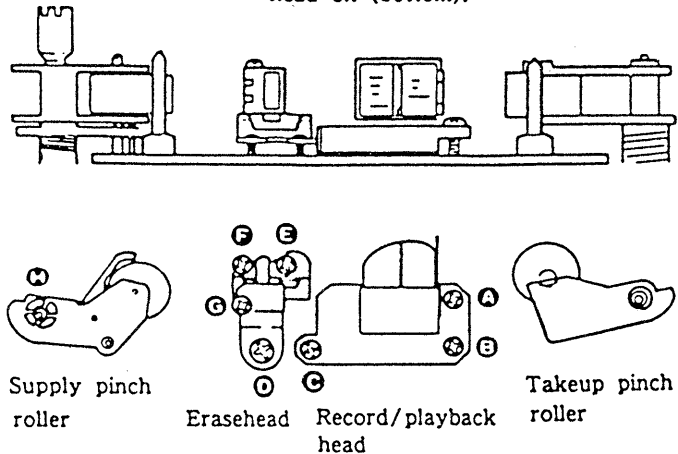

Pinch Roller Pressing Force Measurement

Mode : playback

Hook needle of the tension gauge to the pinch roller shaft and push back pinch roller to detach it from capstan. Then, return it gradually to capstan and read the gauge when the pinch roller begins turning.

Standard Limits :

Tape-up side : 270 - 350g (9.5 - 12oz)

Supply side : 180 - 280g (6.4 - 9.9oz)

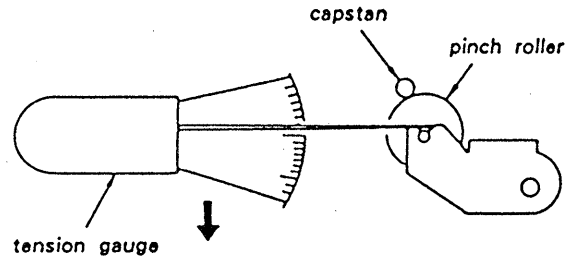

3-2. ELECTRICAL ADJUSTMENTS

Note: The adjustment should be performed in the order given in this service manual.

The adjustments should be performed for both L-CH and R-CH.

- Simultaneous REC/PB Mode :
Input the signals to LINE IN terminal and set to REC mode. Set the monitor switch to TAPE, and monitor the recorded signal for LINE OUT terminal.
- Switch Position :
DOLBY NR OFF
TIMER OFF
MONITOR TAPE
HX PRO OFF
CALIBRATION OFF
CD DIRECT OFF
BIAS CENTER CLICK
REC LEVEL CENTER CLICK
- Standard Record :
Deliver the standard input signal level to the input jack and set the REC LEVEL control to obtain the standard output signal level.

Standard Input Level

Input Terminal	LINE IN
source impedance	10 kΩ
input level	0.25 V (-10 dB)

Standard Output Level

Output Terminal	LINEOUT
load impedance	47 kΩ
output level	0.44 V (-5 dB)

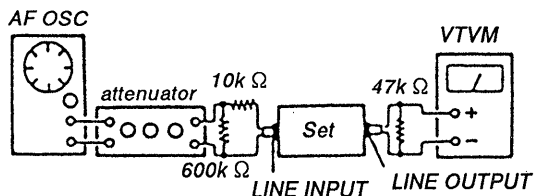

Torque Adjustment and Measurement

1. Insert a tape for torque measurement, CQ-102C, and put the set to PLAY mode. Adjust RV801 so that the reading of the torque meter is $40 \pm 3g \cdot cm$.
2. After the adjustment, measure the back-tension and the FF/REW torque and check that the following specifications are satisfied.

Torque	Torque Meter	Reading
FWD	CQ-102C	$35 - 45g \cdot cm$ ($0.49 - 0.62oz \cdot inch$)
FWD Back tension	CQ-102C	$7 - 11g \cdot cm$ ($0.097 - 0.15oz \cdot inch$)
FF/REW	CQ-201B	$65 - 90g \cdot cm$ ($0.9 - 1.4oz \cdot inch$)

Tape Speed/WOW Check

Procedure:

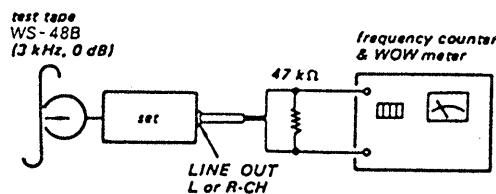

1. Measure the output frequency and the WOW value while playing back the tape top of the test tape.
2. Turn over the test tape, measure the output frequency and the WOW value, and check the difference from the values of the step 1.

Adjustment Limits :

TAPE SPEED deviation : within 2,985 to 3,015Hz
 WOW (WRMS) : 0.05 % or less

MPX FILTER Check

Setting : DOLBY switch : OFF
MPX FILTER switch : OFF

Procedure :

1. Mode: stop

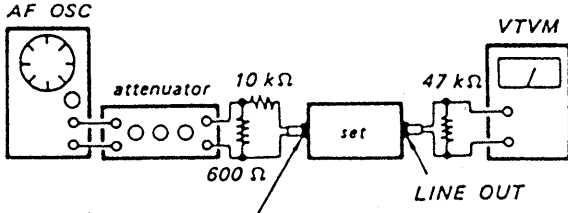

LINE IN
315 Hz, 0.25 V (-10dB)

2. Apply 315Hz, 0.25V (-10dB) signal and adjust REC LEVEL (RV502) control so that the LINE OUT level is 0.44V (-5dB).
3. Apply 19kHz 0.25V (-10dB) signal and confirm that the LINE OUT level is 0.013V (-35dB) or less.

Adjustment Limits :

DOLBY NR switch : B or C
MPX FILTER switch : Line output level when ON.
315Hz : Within 0.49 to 0.39V (within -4dB to -6dB)
19kHz : 0.013V (-35dB) or less

Record/Playback Head Azimuth Adjustment

Procedure :

1. Mode : playback

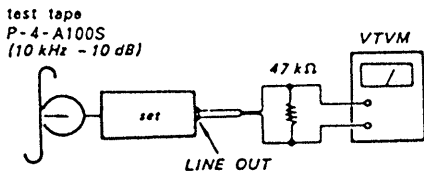

2. Turn the adjustment screw for the maximum output levels. If these levels do not match, turn the adjustment screw until both of output levels match together within 1dB.

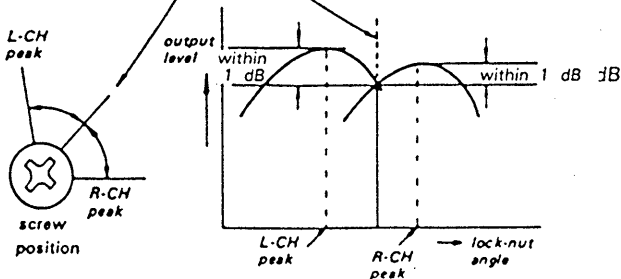

Adjustment Location :

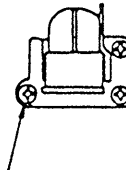

adjustment screw

Playback Level Adjustment

Procedure :

1. Mode : playback

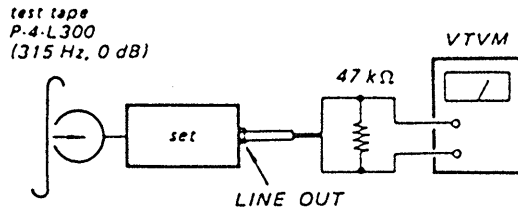

Adjust RV101 (L-CH) and RV201 (R-CH) to obtain the specified LINE OUT level.

Adjustment Limits :

LINE OUT level : 0.338 to 0.301 V
(-7.2 to -8.2 dB)
Level difference between channels :
less than 0.5 dB

Check that the LINE OUT level does not change in playback mode while changing the mode from playback to stop several times.

3. Phase check
- Play mode -

Reference tape for adjustment
P-4-A100
(10kHz, -10dB)

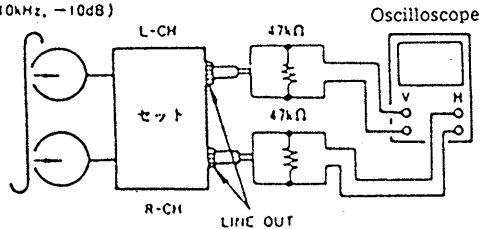

4. Check that the phase difference between L-ch and R-ch is within 0 ~ (same to 90°).

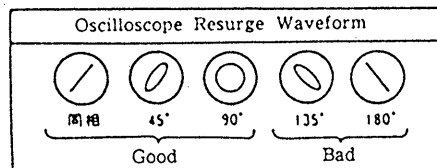

Erase Current Adjustment

1. Mode : record

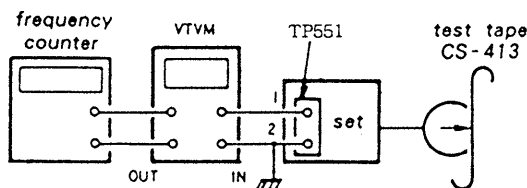

2. Adjust RV553 so that the reading on VTVM is 110mV (erase current = 110mA).
3. And then confirm that the reading on the frequency counter is 160kHz.

Adjustment Limits :

Erase current : 105mA to 110mA
 Frequency : 160 ± 6kHz

Bias Current Adjustment

Note : This adjustment should be made before Record Bias Adjustment.

Procedure :

1. Preset RV303 (L-CH) and RV403 (R-CH) and RV554 in the center position, and record with no signal.
2. Adjust T401 (L-CH) and T301 (R-CH) for minimum readings on the digital voltmeter.

Adjustment Limits :

120mV or less. (reference)

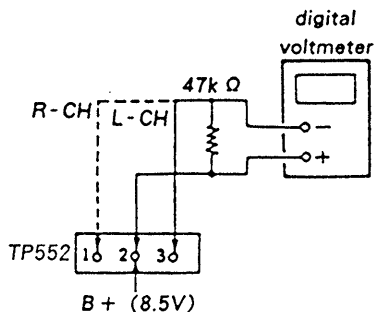

CrO₂ Bias and Record Level Adjustment

Note : This adjustment should be made before Record Bias Adjustment.

Setting:

REC LEVEL knob: standard record position
 (See page 13.)

Procedure:

1. Mode: simultaneous REC/PB

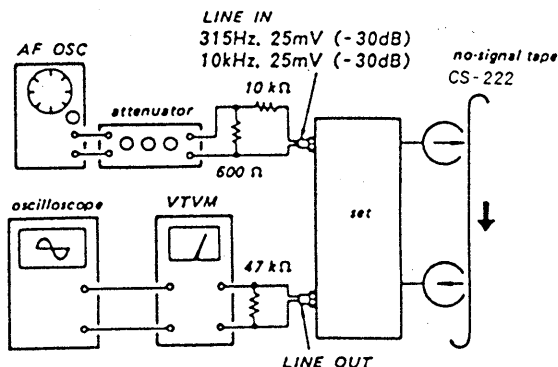

2. Adjust RV403 (L-CH) and RV303 (R-CH) so that the playback output level of 10kHz signal is 0.3dB - 0.3dB with respect to that of 315Hz. . . . Record Bias Adjustment.
3. Adjust RV401 (L-CH) and RV301 (R-CH) so that the playback output level of 315kHz is - 25.3dB to - 24.7dB. . . . Record Level Adjustment.

Metal Bias Adjustment

Setting :

REC LEVEL Knob : standard record position
 (See page 13.)

Procedure :

1. Mode : simultaneous REC/PB

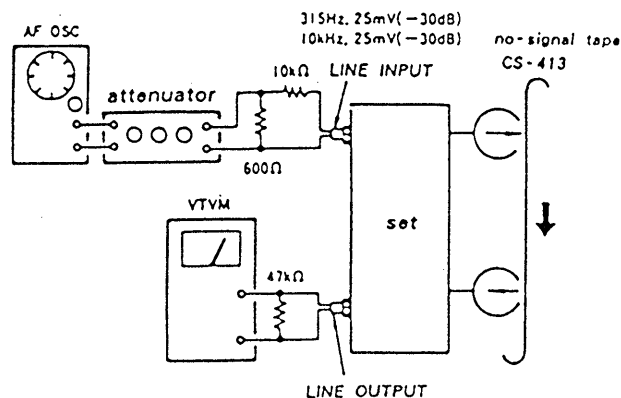

2. Adjust RV554 so that the difference between the playback output at 315Hz and that of 10kHz in R-CH is within 0.3 dB to -0.3dB.

Normal Bias Adjustment

Setting:

REC LEVEL knob: standard record position
(See page 13.)

Procedure:

1. Mode: simultaneous REC/PB

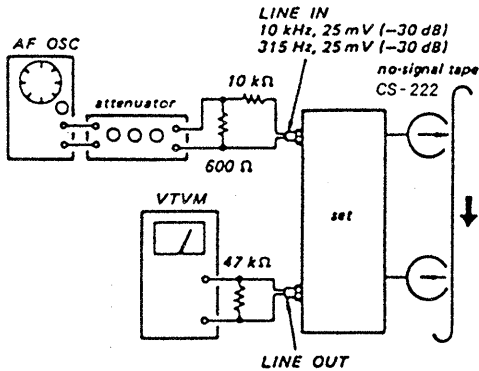

2. Adjust RV302 (L-CH) and RV402 (R-CH) so that the difference between the playback output at 315Hz and that of 10kHz in R-CH is within 0.3dB to -0.3dB.
3. Set the HXPRO switch to OFF.
4. Adjust RV104 (L-CH) and RV204 (R-CH) so that the difference between the playback output at 10kHz when the HXPRO is ON and that of 10kHz when ON is within 0.5dB to -0.5dB.

Calibration OSC and Calibration Meter Adjustment

Setting: CALBRATION switch: ON

Procedure (OSC OUT LEVEL):

1. Mode: record (no-signal (LINE INPUT))

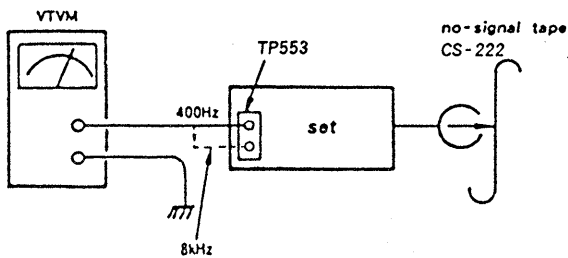

2. Adjust RV551 so that a check-point level at 400Hz is 9.5dB to 10.5dB.
3. Adjust RV552 so that a check-point level at 8kHz is 9.5dB to 10.5dB.

Procedure (CAL METER ADJ):

1. Put the set in record mode and adjust RV202 (HIGH) so that HIGH FREQ segments in the CAL LEVEL meter light thoroughly up to 0 VU as shown in the figure below. Segment (a) may flicker.
2. Preset RV102 (LOW) so that segment (a) in LOW FREQ CAL LEVEL meter lights. Then adjust RV102 to the point where segment (a) goes out.

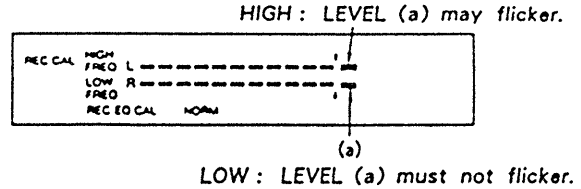

Adjustment Location : MAIN (A) BOARD (COMPONENT SIDE)

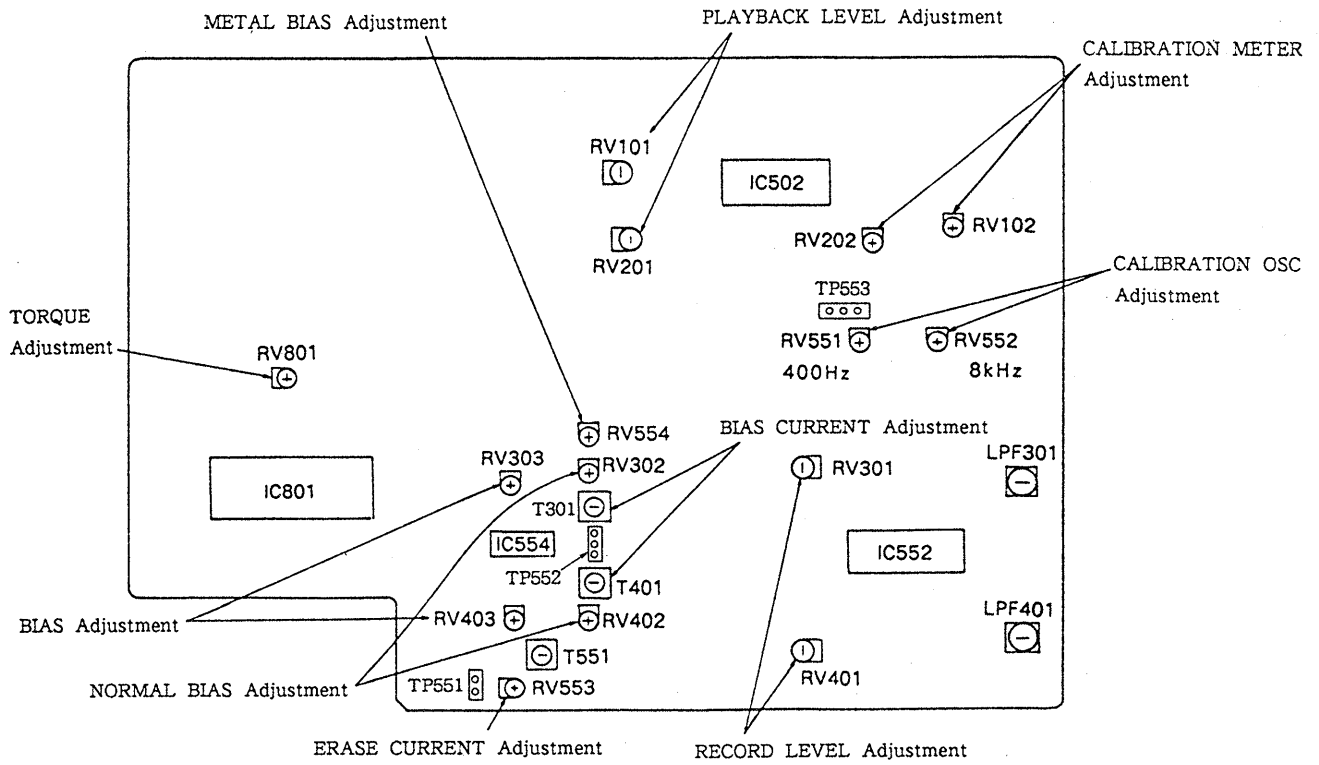

SECTION 4 DIAGRAMS

4-1. DESCRIPTION ON IC

IC502, IC552 (CX20188)

An electronic switch circuit for the operation mode control is included. Controls are performed by adding direct current voltages VH, VM, and VL to Dolby OFF/B/C and calibration/REC/Playback terminals.

CX20188	Pin name	Description
Pin No.		
1.	Vcc	Positive power supply terminal.
2, 41.	REC IN	Recording input terminal.
3.	I REF	Reference current input terminal.
4, 39.	PB IN	Playback input terminal.
5.	CAL/REC/PB	Calibration/recording/playback select terminal
6, 37.	PB FB	Playback feedback terminal.
7, 36.	REC FB	Recording feedback terminal.
8, 35.	GND	GND terminal.
9, 34.	LINE OUT	Line output (decode output) terminal.
10, 33.	SSK	Spectral skewing switch terminal.
11, 32.	VF IN	Encode circuit input terminal.
12, 31.	HPF H	HLS high-pass filter terminal.
13, 30.	TCH 2	HLS detector time constant terminal 2.
14, 29.	TCH 1	HLS detector time constant terminal 1.
15, 28.	WT H	HLS encoder error reduction terminal.
16, 27.	TCL 2	LLS detector time constant terminal 2.
17, 26.	TCL 1	LLS detector time constant terminal 1.
18, 25.	WT L	LLS encoder error reduction terminal.
19, 24.	HPF L	LLS high-pass filter terminal.
20, 23.	ANT S	Anti-saturation terminal.
21, 22.	REC OUT	Recording output (encode output) terminal.
38.	OFF/B/C	Dolby NR off/B type/C type select terminal.
40.	CAL IN	Calibration input terminal.
42.	Vee	Negative power supply terminal.

IC901 (M50940 - 313SP)

Level meter display of 24-segment fluorescent display, etc., are performed by receiving direction from the master microcomputer (IC801).

Pin No.	Pin name	I/O	Description
1.	Vref	I	A/D input-port reference voltage input(+5V)
2.	ϕ L	I	Not used. (Connected to +5V)
3.	ϕ R	I	Not used. (Connected to +5V)
4.	DATA	I	Data input from the master microcomputer(IC801)(analog)
5.~6.	ADE1~ADRO	I	Data input from the master microcomputer(IC801)(analog)
7.	KEY	I	Not used. (Connected to +5V)
8.	LEVEL L	I	Level meter L-CH input(analog) from the meter amplifier(IC514)
9.	LEVEL R	I	Level meter R-CH input(analog) from the meter amplifier(IC514)
10.~13.	GRID6~GRID3	0	Not used.
14.~15.	GRID2~GRID1	0	Fluorescent display grid output
16.	$\overline{\text{COO}}$	0	Not used.
17.	$\overline{\text{PLAY}}$	0	Not used. (Connected to pin ⑩.)
18.	$\overline{\text{PLAY}}$	0	Not used.
19.	$\overline{\text{PAUSE}}$	0	Not used.
20.	$\overline{\text{REC}}$	0	Not used.
21.	$\overline{\text{TAPE}}$	0	Fluorescent display segment output("TAPE" displayed). "L": TAPE displayed. "H": SOURCE displayed.
22.	$\overline{\text{OVER LEVEL}}$	0	Fluorescent display segment output("OVER LEVEL" displayed). It is displayed when "L".
23.	$\overline{\text{TYPE I}}$	0	Fluorescent display segment output("TYPE I" displayed). It is displayed when "L".
24.	$\overline{\text{TYPE II}}$	0	Fluorescent display segment output("TYPE II" displayed). It is displayed when "L".
25.	$\overline{\text{TYPE IV}}$	0	Fluorescent display segment output("TYPE III" displayed). It is displayed when "L".
26.	CNVss	-	Power supply terminal(GND)
27.	$\overline{\text{RESET}}$	I	Reset input
28.	XIN	I	Clock input(4MHz)
29.	XOUT	0	Clock output.
30.	XCIN	-	Not used. (Connected to GND)
31.	XCOUT	-	Not used.
32.	Vss	-	Power supply terminal(GND)
33.	Φ	0	Not used.
34.	VER	I	Version switching input(Always set to "L")
35.	$\overline{\text{TEST}}$	I	Test mode input. "L": All the lamps of the meter are lit.
36.	CAL	I	Calibration switch(S602) input. "L": CAL mode. "H": Normal mode.
37.	IN	I	Not used. (Connected to GND.)
38.	VP	I	Fluorescent display segment output's pull-down power supply terminal(-22V)
39.~62.	S23~S0	0	Fluorescent display segment output(meter display)
63.	AVcc	-	Power supply terminal(+5V)
64.	Vcc	-	Power supply terminal(+5V)

IC801 (M50964-226SP)

Pin No.	Pin name	I/O	Description
1.	VCC		Power supply: +5V.
2.	AVss		Analog GND.
3.	Vref	I	A/D port reference voltage input.
4.	DA		Not used for this model.
5.	PWM		Not used for this model.
6.	P.OFF		Not used for this model. Connected to GND.
7.	LED	O	PAUSE LED output.
8.	LED	O	REC LED output.
9.	LED	O	PLAY LED output.
10.	AD1	I	Key input. 0V=▲, 1V=■, 2V=◀, 3V=▶, 4V=●.
11.	AD2	I	Key input. 0V=▶, 1V=■, 2V=◀, 3V=▶, 4V=○.
12.	AMS SIG	I	AMS signal input. No song detected = Low. Song detected = High.
13.	AD4	I	Key input. 2V = DISPLAY, 3V = MONITOR.
14.	CODE	I	Remote control category select switch.
15.	ALB		Connected to 5V.
16.	φR	I	Take-up reel base sensor input.
17.	φL	I	Supply reel base sensor input.
18.	C RESET		Model select input. Connected to GND.
19.	C MEMORY		Model select input. Connected to GND.
20.	COO		Not used for this model.
21.	POWER IN	I	Power on and off detection.
22.	SIRW	I	SIRCS phase input.
23.	STRE	I	SIRCS reverse phase input.
24.	T-REC	I	Timer REC switch input.
25.	T-PLAY	I	Timer PLAY switch input.
26.	TNT	I	External interruption input. Interruption process is performed when the power is on or off.
27.	Vss		GND.
28.	RESET	I	Reset input.
29.	XIN	I	Clock input (4 MHz).
30.	XOUT	O	Clock output (4 MHz).
31.	φout		Not used for this model.
32.	Vss		GND.
33.	C1	I	Rotary encoder input to detect the position of the head base of the mechanical block.
34.	C2	I	Rotary encoder input to detect the position of the head base of the mechanical block.
35.	C3	I	Rotary encoder input to detect the position of the head base of the mechanical block.
36.	C4	I	Rotary encoder input to detect the position of the head base of the mechanical block.
37.	OPEN SW	I	OPEN switch input of the mechanical block.
38.	CLOSE SW	I	CLOSE switch input of the mechanical block.
39.	DOOR SW	I	DOOR switch input of the mechanical block.
40.	REC SW	I	REC switch input of the mechanical block.
41.	M PLAY	O	Reel motor rotates at PLAY speed.
42.	M FAST	O	Reel motor rotates at FF/REW speed.
43.	M FWD	O	Reel motor rotates.
44.	M REV	O	Reel motor rotates in reverse.
45.	CAM DOWN	O	Head base DOWN output of the mechanical block
46.	CAM UP	O	Head base UP output of the mechanical block
47.	C OFF	O	Counter light-off output
48.	M OFF	O	Meter light-off output
49.	BIAS	O	Bias oscillation on and off control
50.	R MI	O	REC MUTE.
51.	M MI		Not used for this model.
52.	T MI	O	Tape MUTE. Goes to low when the tape is being played.
53.	S MI	O	Source MUTE. Goes to low three seconds after the power is on.
54.	AMS	O	AMS switch output. Goes to low when AMS is being used.
55.	MONITOR		Not used for this model. Connected to GND.
56.	HALF		Not used for this model. Connected to GND.
57.	DAT3	O	Outputs parallel data for the counter display.
58.	DAT2	O	Outputs parallel data for the counter display.
59.	DAT1	O	Outputs parallel data for the counter display.
60.	DATO	O	Outputs parallel data for the counter display.
61.	DATD	O	Outputs parallel data for the counter display.
62.	CLK	O	Clock output to transmit the parallel data.
63.	LATCH	O	Output for latching the transmitted data.
64.	CAL IN	I	CAL switch input.

4-2. CIRCUIT BOARDS LOCATION

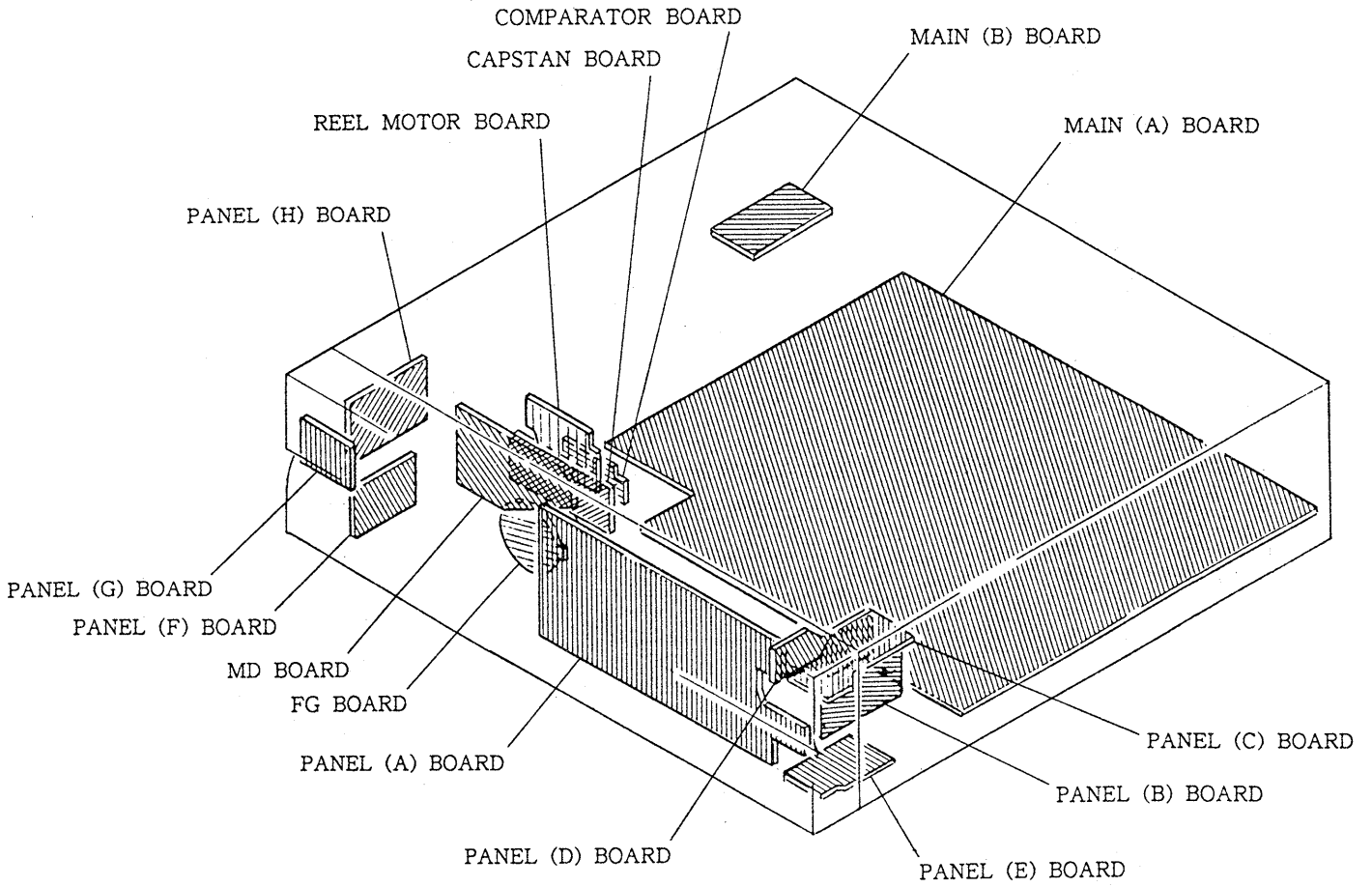

4-3. IC BLOCK DIAGRAMS

IC502, 552 CX20188

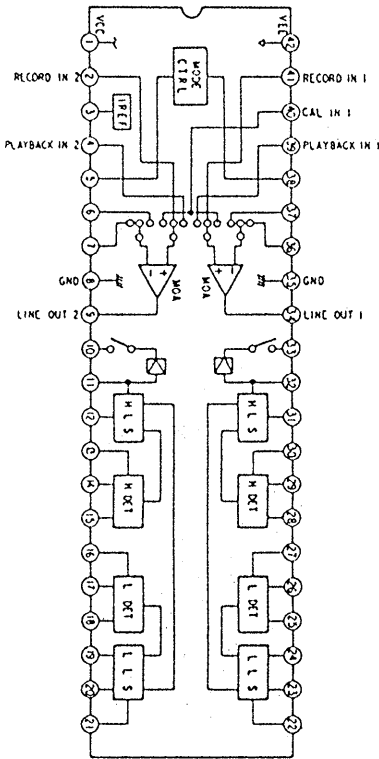

IC902B CX20174

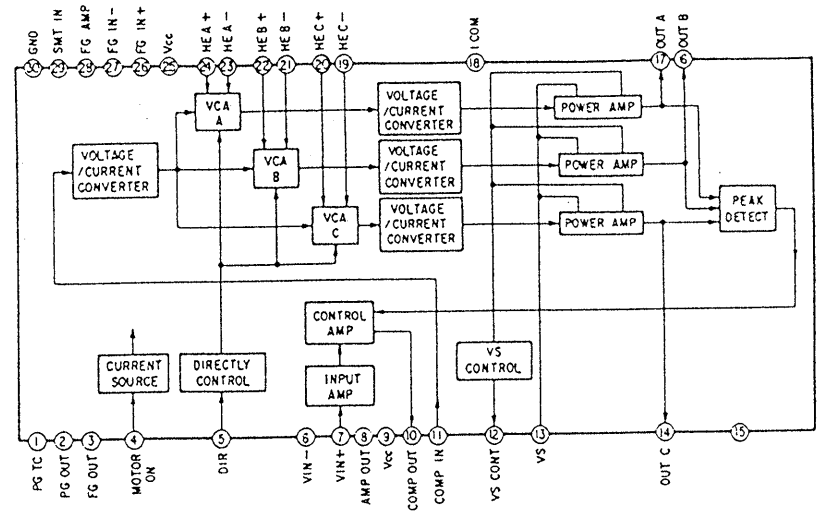

IC952 TC 9142P

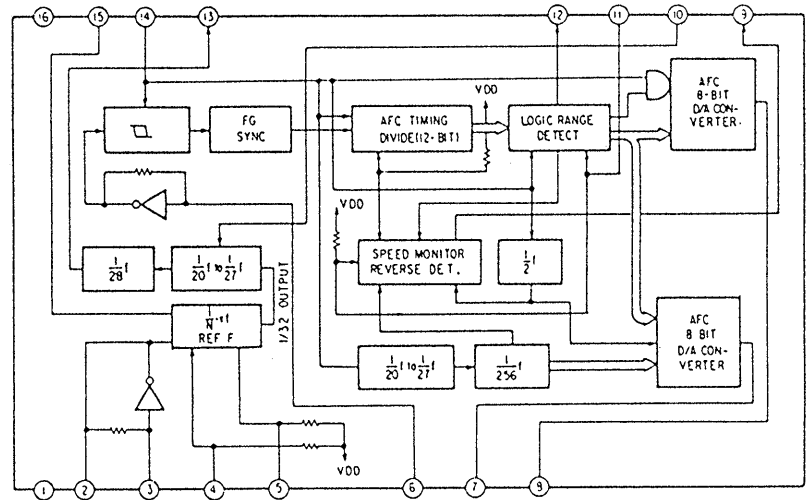

IC554 μ PC1297CA

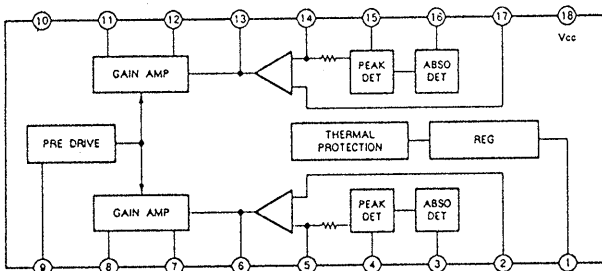

IC802 BA6219B

IC803 LB1641

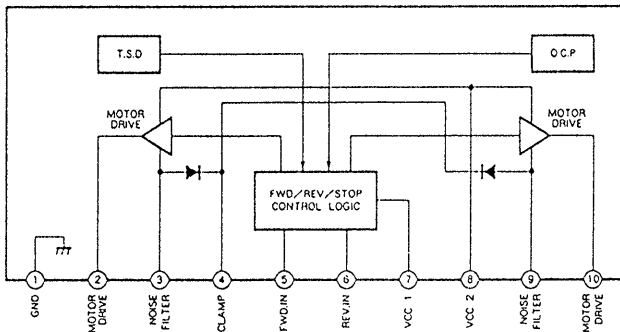

4-5. SEMICONDUCTOR LEAD LAYOUTS

GP2S22B

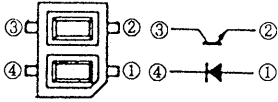

OH009

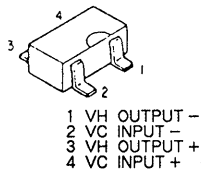

2SK246-GR

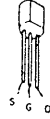

30DF2

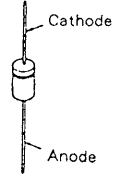

LB1641

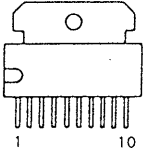

**2SA1409-LK
2SB1116A-L
2SC945-P
2SC1815-Y**

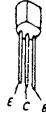

**HZS6C3L
HZS9B2L
UZP-8.2BB
UZL-6L3
UZL-12H1**

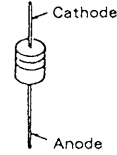

**1N4148M
10E2N**

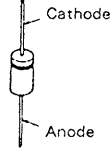

**BN1L3Z-K
2SA1175-HFE**

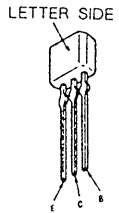

**2SB1094-LK
2SD1585-LK
2SD2012**



**SEL1210S
SEL1210S-C
SEL1910A-C**

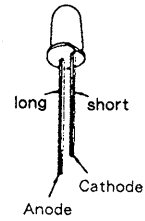

**DTA114ES
DTA144ES
DTC114ES
DTC144ES
2SC2603-EF
2SD2144S**



4-6. PRINTED WIRING BOARDS - MAIN SECTION - See page 21 for Circuit Boards Location. See page 26 for Semiconductor Lead Layouts.

• Semiconductor Location

Ref. No.	Location	Ref. No.	Location
D101	D-16	Q105	B-20
D102	F-14	Q106	B-18
D103	F-14	Q107	C-15
D104	F-13	Q108	C-15
D201	D-16	Q201	F-19
D202	H-14	Q202	F-19
D203	F-14	Q203	F-20
D204	F-13	Q204	F-20
D501	F-18	Q205	F-20
D502	F-18	Q206	F-18
D503	F-18	Q207	D-15
D504	F-18	Q208	D-16
D505	F-17	Q301	H-17
D506	F-15	Q302	H-17
D507	F-16	Q303	H-17
D508	F-14	Q304	H-18
D509	F-16	Q305	H-18
D551	G-21	Q306	H-19
D552	G-21	Q401	J-17
D553	G-20	Q402	J-17
D554	G-21	Q403	J-17
D555	G-20	Q404	I-18
D556	J-21	Q405	I-18
D601	D-23	Q406	I-19
D602	D-23	Q501	F-19
D603	C-23	Q502	F-18
D604	C-23	Q503	C-15
D605	E-21	Q504	H-14
D701	D-24	Q505	F-17
D702	D-24	Q551	J-20
D703	E-23	Q552	J-20
D704	E-23	Q553	J-20
D705	D-24	Q554	I-21
D706	E-24	Q555	I-21
D707	D-25	Q556	G-21
D708	B-25	Q557	G-20
D712	B-24	Q558	G-20
D713	C-26	Q559	E-15
D714	D-26	Q560	E-16
D715	D-25	Q601	E-21
D716	E-26	Q602	B-21
D801	G-25	Q603	E-21
D802	G-24	Q604	E-21
D803	G-24	Q605	B-21
		Q606	B-21
IC501	D-19	Q607	E-21
IC502	C-17	Q611	C-21
IC503	C-14	Q701	B-23
IC504	D-14	Q702	B-24
IC505	D-15	Q703	B-25
IC506	E-14	Q704	B-23
IC507	E-17	Q706	B-24
IC541	B-2	Q707	B-25
IC551	I-14	Q708	B-26
IC552	I-15	Q709	D-25
IC553	I-18	Q710	D-25
IC554	I-21	Q801	G-26
IC555	E-15	Q802	G-25
IC801	H-24	Q803	G-25
IC802	F-23	Q804	G-25
IC803	G-23	Q805	G-25
IC902A	J-6	Q806	G-25
IC951	J-3	Q807	G-25
IC952	J-2	Q808	G-24
IC1001	H-10	Q809	G-24
IC1002	H-9	Q810	F-24
		Q811	G-24
Q101	B-20	Q812	I-24
Q102	B-19	Q813	I-23
Q103	B-20	Q814	I-23
Q104	B-20		

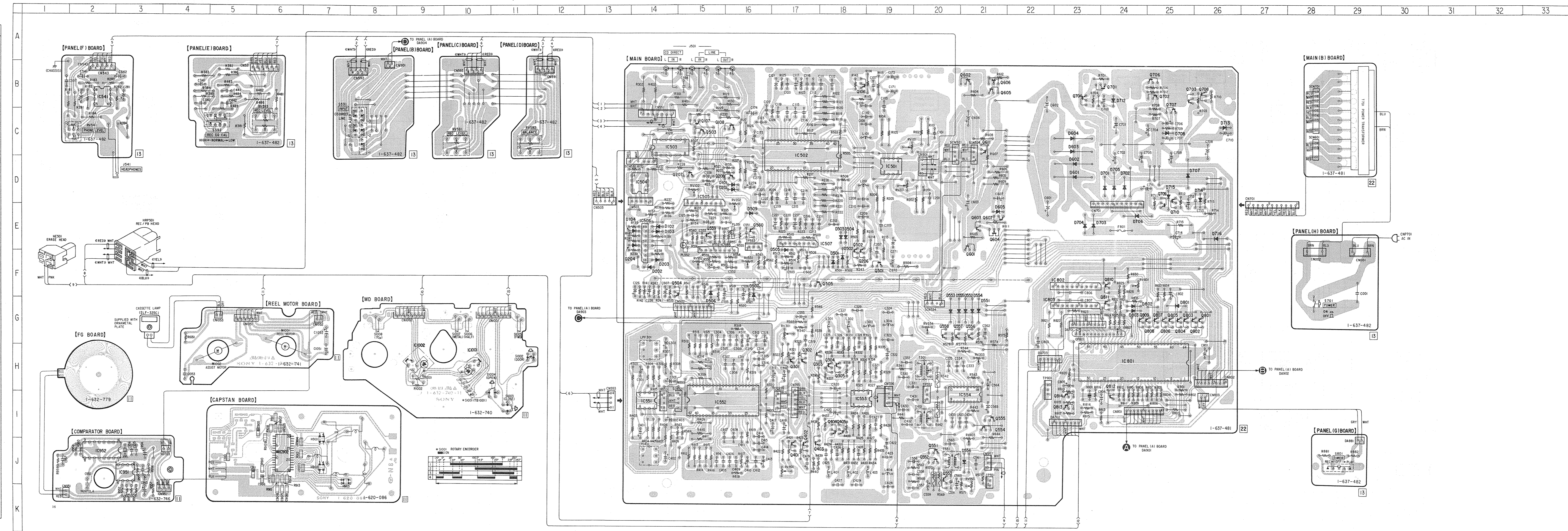

Note on Mounting Diagram:
 ○ : parts extracted from the component side.
 ● : parts mounted on the conductor side.

4-7. SCHEMATIC DIAGRAM - MAIN SECTION - See page 22 for IC Block Diagrams.

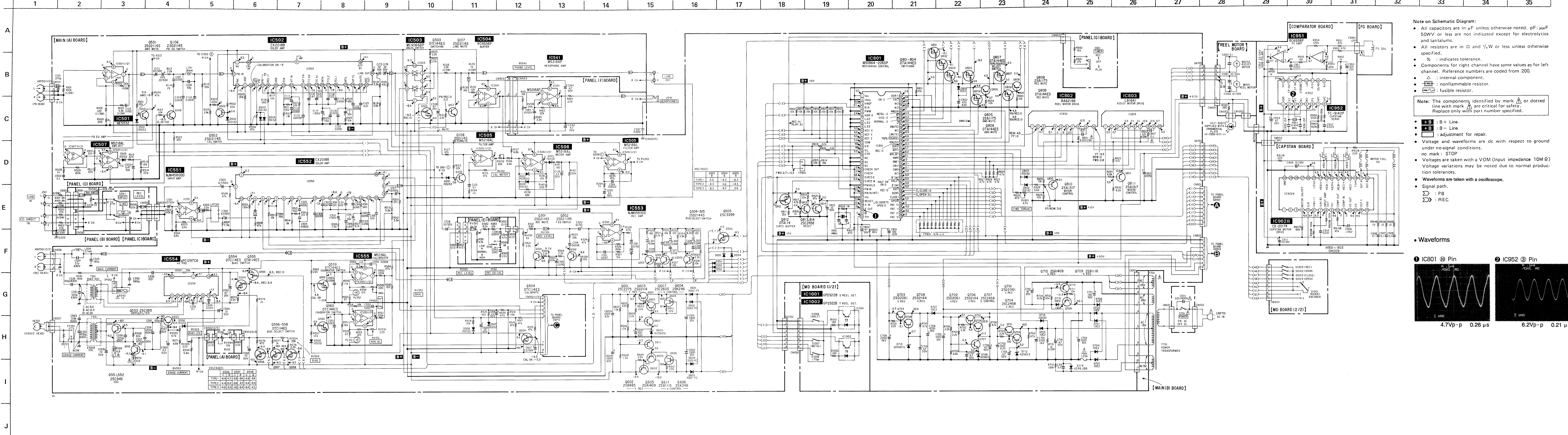

Note on Schematic Diagram:

- All capacitors are in μF unless otherwise noted. pF : μF
- 50WV or less are not indicated except for electrolytics and tantalums.
- All resistors are in Ω and $1/4\text{W}$ or less unless otherwise specified.
- % : indicates tolerance.
- Components for right channel have same values as for left channel. Reference numbers are coded from 200.
- Δ : internal component.
- \square : nonflammable resistor.
- --- : fusible resistor.

Note: The components identified by mark Δ or dotted line with mark Δ are critical for safety. Replace only with part number specified.

Legend:

- --- : B+ Line
- --- : B- Line
- --- : adjustment for repair.

Waveforms:

- Voltage and waveforms are dc with respect to ground under no-signal conditions.
- no mark : STOP
- Waveforms are taken with a VOM (input impedance 10M Ω)
- Voltage variations may be noted due to normal production tolerances.
- Waveforms are taken with an oscilloscope.
- Signal path.
- --- : PB
- --- : REC

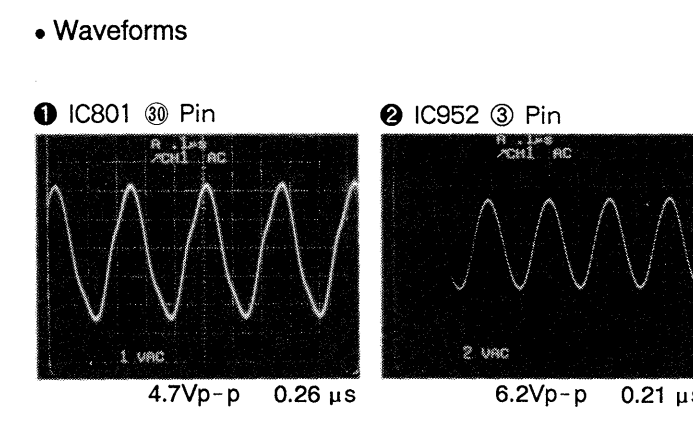

1 2 3 4 5 6 7 8 9 10

A
B
C
D
E
F
G

[PANEL (A) BOARD]

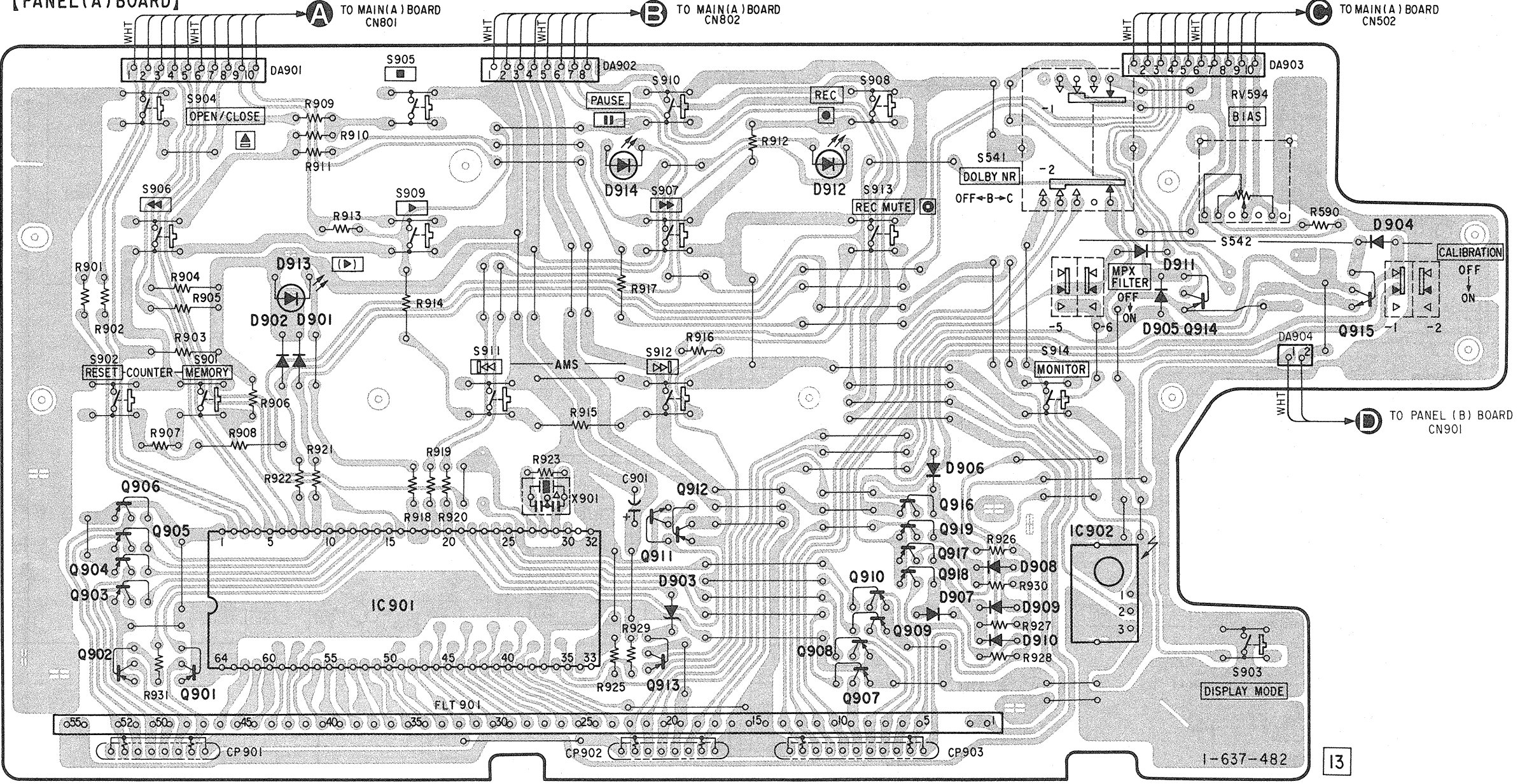

• Semiconductor Location

Ref. No.	Location
D901	C-3
D902	C-3
D903	D-5
D904	B-9
D905	C-8
D906	D-7
D907	D-7
D908	D-7
D909	D-7
D910	E-7
D911	B-8
D912	B-6
D913	C-3
D914	B-5
IC901	D-3
IC902B	D-8
Q901	E-2
Q902	E-2
Q903	D-2
Q904	D-2
Q905	D-2
Q906	D-2
Q907	F-6
Q908	E-6
Q909	F-6
Q910	D-6
Q911	D-5
Q912	D-5
Q913	E-5
Q914	C-8
Q915	C-9
Q916	D-7
Q917	D-7
Q918	D-7
Q919	D-7

16

Note on Mounting Diagram:
 ● ○ — : parts extracted from the component side.

5-2. PANEL SECTION

- A : PANEL (H)
- B : PANEL (G)
- C : PANEL (D)
- D : PANEL (C)
- E : PANEL (B)
- F : PANEL (E)

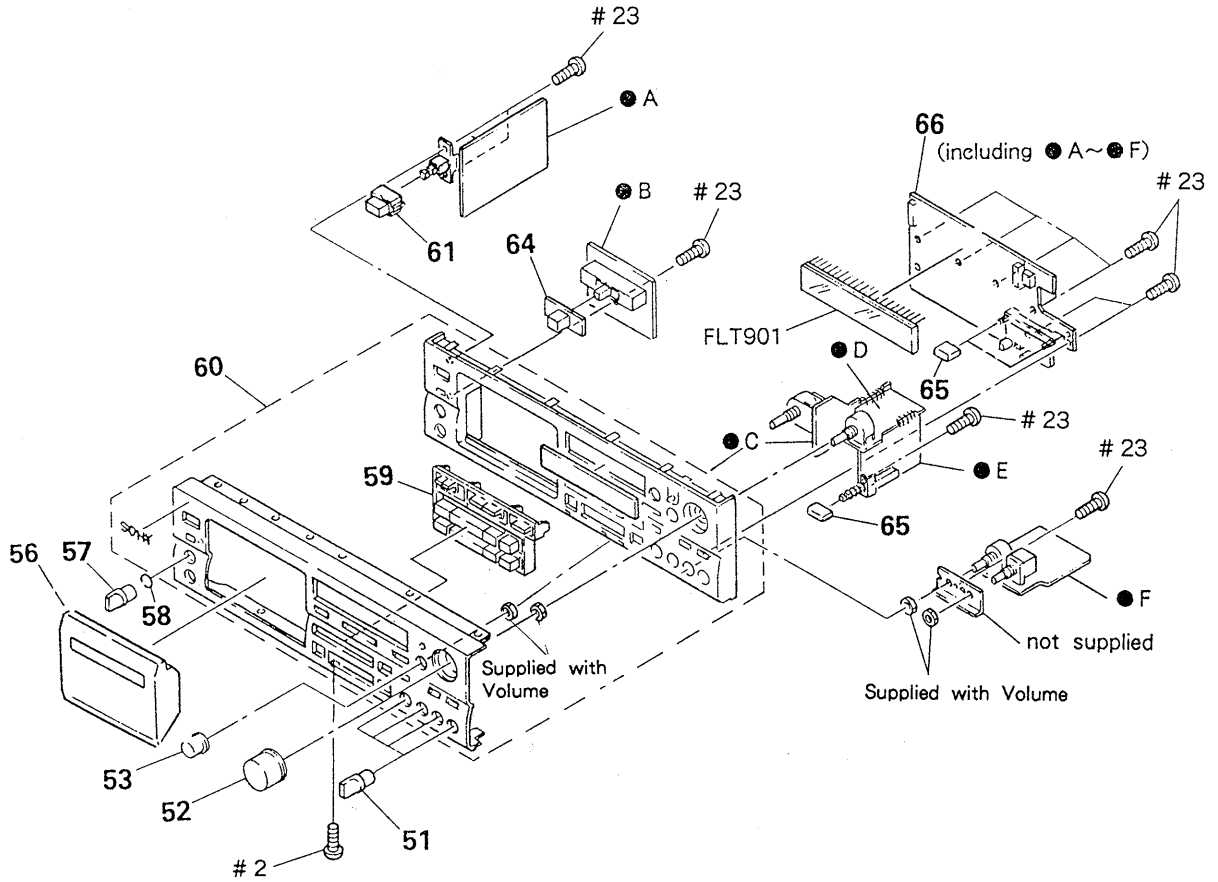

Ref. No.	Part No.	Description	Remarks	Ref. No.	Part No.	Description	Remarks
51	X-3362-818-1	KNOB (DIA. 12) ASSY (B), FLAT		60	A-2004-076-A	PANEL ASSY, FRONT	
52	X-3362-289-1	KNOB (VOL) ASSY		61	3-354-912-01	KNOB, POWER	
53	X-3365-387-1	KNOB (BAL)		64	4-922-518-01	KNOB (TIMER)	
56	X-3365-080-1	LID ASSY, CASSETTE		65	3-364-165-01	BUTTON (14X5)	
57	3-354-931-01	KNOB (DIA. 10)		66	* A-2006-781-A	PANEL BOARD, COMPLETE	
58	3-354-981-01	SPRING (SUS), RING		FLT901	1-519-560-21	INDICATOR TUBE, FLUORESCENT	
59	X-3362-290-1	BUTTON (BLOCK) ASSY					

5-3. MECHANISM SECTION-1
(TCM-200D9)

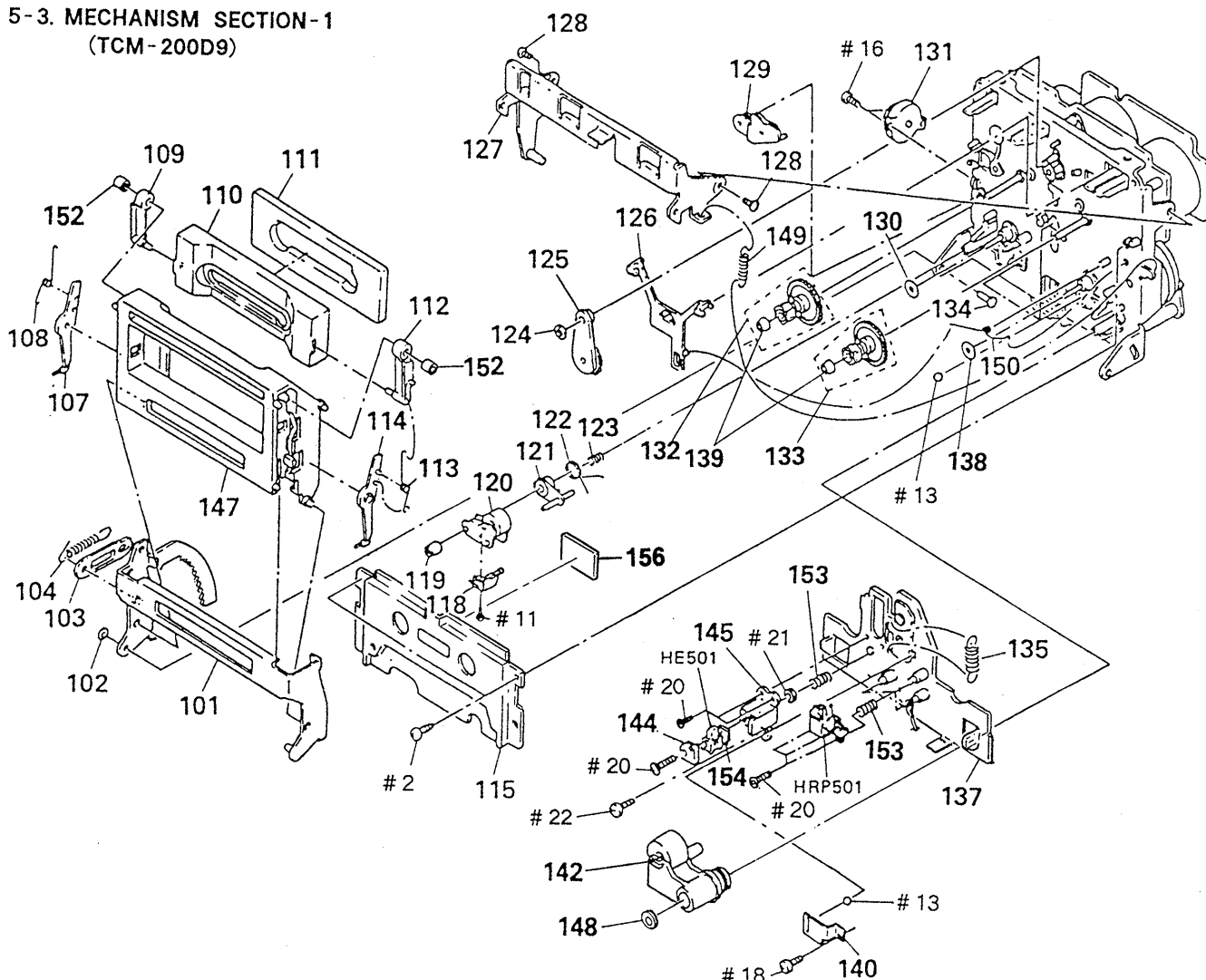

Ref. No.	Part No.	Description	Remarks
101	X-3362-671-1	HOLDER (BG) ASSY, CASSETTE	
102	3-558-708-21	WASHER, STOPPER	
103	* 3-356-717-01	LEVER (JOINT)	
104	3-356-626-01	SPRING, TENSION	
107	3-356-932-01	LEVER (LA)	
108	3-356-927-01	SPRING (LEFT), TORSION	
109	3-356-933-01	LEVER (LB)	
110	3-356-928-01	PLATE (A), ORNAMENTAL	
111	* 3-356-929-01	ABSORBENT, VIBRATION	
112	3-356-931-01	LEVER (RB)	
113	3-356-926-01	SPRING (RIGHT), TORSION	
114	3-356-930-01	LEVER (RA)	
115	X-3356-613-1	PLATE ASSY, ORNAMENTAL	
118	3-564-138-00	GUIDE (S), TAPE	
119	3-356-652-01	NUT (PINCH LEVER S)	
120	X-3356-621-1	LEVER (PINCH LEVER S) ASSY	
121	3-356-660-01	LEVER (PS)	
122	3-356-661-01	SPRING (PINCH LEVER S), TORSION	
123	3-356-657-01	SPRING (PS), COMPRESSION	
124	3-669-465-00	WASHER (1.5), STOPPER	
125	X-3356-641-1	LEVER (FR2) ASSY	
126	3-356-614-01	SLIDER (BRAKE)	
127	* X-3356-608-1	LEVER (LIFTER) ASSY	
128	3-356-601-11	SCREW, STEP	
129	X-3356-623-1	LEVER (BT) ASSY	

Ref. No.	Part No.	Description	Remarks
130	3-356-713-01	WASHER	
131	3-319-224-41	DAMPER, SMALL	
132	X-3356-629-1	GEAR (S) ASSY	
133	X-3356-627-1	GEAR (T) ASSY	
134	3-356-710-01	SHAFT (LEFT) (CASSETTE HOLDER)	
135	3-356-658-01	SPRING (LIMITER H), TENSION	
137	* X-3362-199-1	SLIDER (HEAD CHASSIS D) ASSY	
138	3-332-763-01	RING, OIL RESERVOIR	
139	3-362-308-01	CAP (REEL)	
140	3-356-656-01	SPRING (HEAD PC BOARD), LEAF	
142	X-3356-620-1	LEVER (PINCH LEVER T) ASSY	
144	3-318-433-01	SPRING	
145	* 3-576-977-00	BRACKET, E. HEAD	
147	X-3365-065-1	HOLDER (D9) ASSY, CASSETTE	
148	3-669-596-00	WASHER (2.3), STOPPER	
149	3-356-625-01	SPRING, TENSION	
150	3-356-619-01	SPRING (B), TORSION	
152	3-356-946-01	BUSHING	
153	3-564-121-00	SPRING, COMPRESSION	
154	* 1-608-268-00	ERASE HEAD BOARD	
156	8-719-980-85	DIODE SLF325C	
HE501	1-543-358-11	HEAD, MAGNETIC (ERASE)	
HRP501	1-543-742-11	HEAD MAGNETIC (RECORD/PLAYBACK)	

5-4. MECHANISM SECTION-2
(TCM-200D9)

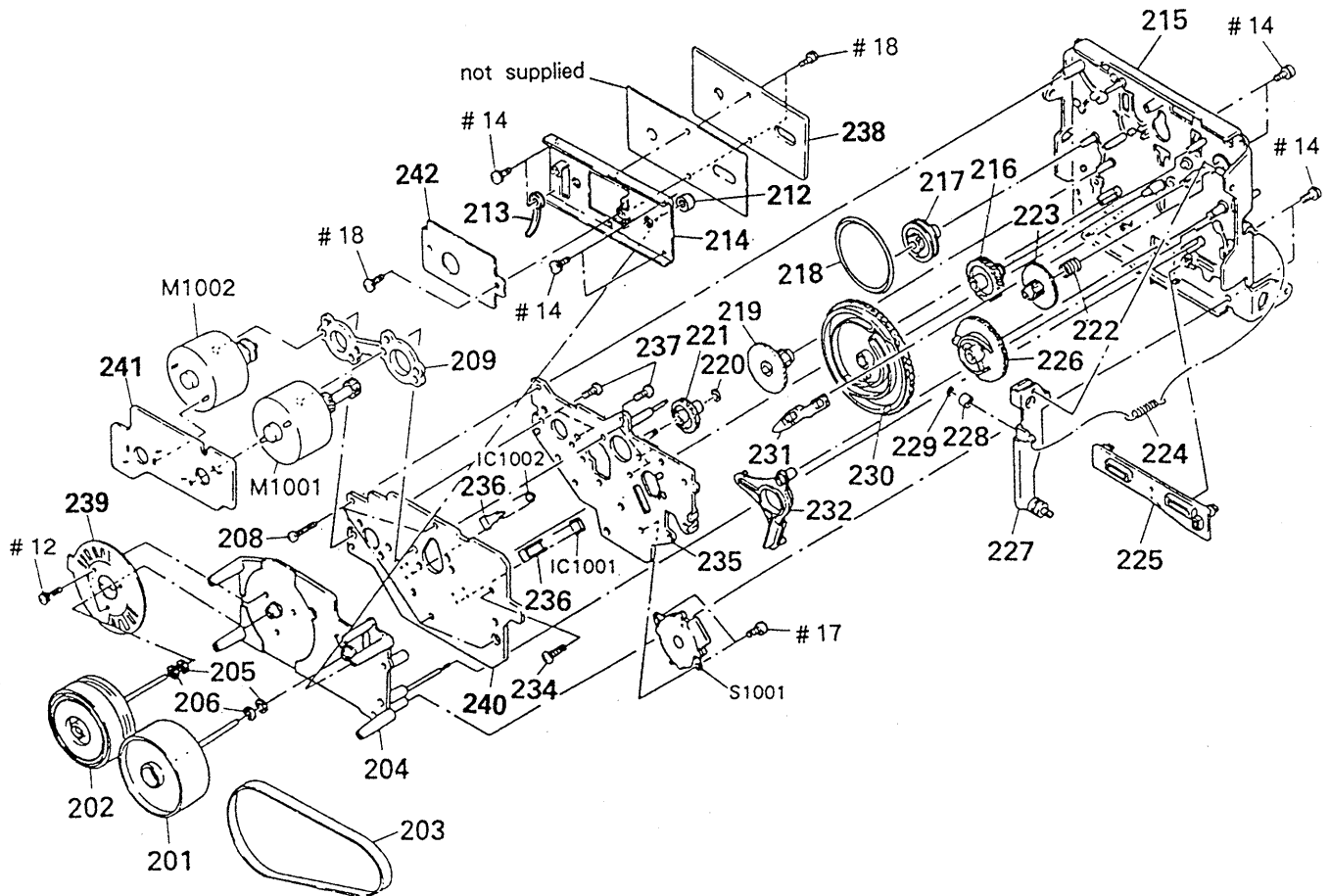

Ref. No.	Part No.	Description	Remarks	Ref. No.	Part No.	Description	Remarks
201	X-3362-284-1	FLYWHEEL (S2.3) ASSY		224	3-376-854-01	SPRING, TENSION	
202	X-3356-619-1	FLYWHEEL (DT) ASSY		225	3-356-653-01	SLIDER (PAUSE)	
203	3-364-600-01	BELT (CAPSTAN)		226	3-356-616-01	GEAR (LOADING CAM)	
204	X-3362-281-1	CHASSIS (D2.3) ASSY		227	* X-3356-606-1	LEVER (LOADING) ASSY	
205	3-356-705-31	WASHER (CAPSTAN)		228	3-356-630-01	ROLLER (LOADING)	
206	3-356-705-21	WASHER (CAPSTAN)		229	3-558-708-11	WASHER, STOPPER	
208	3-355-801-01	SCREW (BTP 2X18)		230	3-356-654-01	GEAR (MODE CAM C)	
209	* 3-356-628-01	SPACER (MOTOR)		231	3-356-617-01	LEVER (SELECTION)	
212	3-364-135-01	RETAINER (S), THRUST		232	3-356-613-01	LEVER (MODE)	
213	3-703-150-11	STOPPER, WIRING		234	3-356-707-01	SCREW (+PTPWH 2X25)	
214	* X-3362-282-1	BRACKET (THRUST RETAINER) ASSY		235	* X-3356-616-1	BRACKET (MOTOR D) ASSY	
215	X-3356-622-1	CHASSIS (C) ASSY, MECHANICAL		236	3-356-631-01	HOLDOR (SENSOR)	
216	3-356-703-01	GEAR (COMMUNICATION C)		237	3-363-804-01	SCREW (+P 2.6X6.5)	
217	3-356-607-01	PULLEY (MODE)		238	A-2006-154-A	CAPSTAN C. O. C BOARD, COMPLETE	
218	3-356-603-01	BELT (MODE)		239	1-632-779-11	PC BOARD, FG	
219	3-356-606-01	GEAR (MODE)		240	* 1-632-740-11	MD BOARD	
220	3-669-465-11	WASHER (1.5), STOPPER		241	* 1-632-741-11	REAL MOTOR BOARD	
221	3-356-702-01	GEAR (COMMUNICATION B)		242	* 1-632-746-11	COMPARATOR BOARD	
222	3-356-605-01	SPRING, COMPRESSION		S1001	1-466-238-11	ENCODER, ROTARY	
223	3-356-609-01	GEAR (LOADING)		M1002	X-3356-604-1	MOTOR (ASSIST) ASSY	
				M1001	X-3356-638-1	MOTOR (REEL R) ASSY	
				IC1001	8-749-920-97	DIODE GP2S22B	
				IC1002	8-749-920-97	DIODE GP2S22B	

SECTION 6
ELECTRICAL PARTS LIST

CAPSTAN C.O.C

COMPARATOR

MD

NOTE:

The components identified by mark Δ or dotted line with mark Δ are critical for safety.
Replace only with part number specified.

When indicating parts by reference number, please include the board name.

- Due to standardization, replacements in the parts list may be different from the parts specified in the diagrams or the components used on the set.
- -XX, -X mean standardized parts, so they may have some difference from the original one.
- RESISTORS
All resistors are in ohms.
METAL: metal-film resistor
METAL OXIDE: Metal Oxide-film resistor
F: nonflammable
- Items marked "*" are not stocked since they are seldom required for routine service. Some delay should be anticipated when ordering these items.
- SEMICONDUCTORS
In each case, u: μ , for example:
uA...: μ A..., uPA..., μ PA...,
uPB..., μ PB..., uPC..., μ PC...,
uPD..., μ PD...
- CAPACITORS:
uF: μ F
- COILS
uH: μ H

Ref. No.	Part No.	Description	Remarks	Ref. No.	Part No.	Description	Remarks
	A-2006-154-A	CAPSTAN C. O. C BOARD, COMPLETE *****		C956	1-162-203-31	CERAMIC 15PF 5% 50V	
	1-216-296-00	METAL CHIP 0 5% 1/8W < CAPACITOR >		C957	1-136-159-00	FILM 0.033uF 5% 50V	
C905	1-124-779-00	ELECT CHIP 10uF 20% 16v				< CONNECTOR >	
C906	1-135-091-00	TANTALUM CHIP 1uF 20% 16V		CN951 *	1-564-718-11	PIN, CONNECTOR (SMALL TYPE) 2P	
C907	1-163-077-00	CERAMIC CHIP 0.1uF 10% 25V		CN952 *	1-564-518-11	PLUG, CONNECTOR 3P	
C908	1-163-077-00	CERAMIC CHIP 0.1uF 10% 25V				< IC >	
C909	1-163-077-00	CERAMIC CHIP 0.1uF 10% 25V		IC951	8-759-945-58	IC RC4558P	
C910	1-163-205-00	CERAMIC CHIP 0.001uF 5% 50V		IC952	8-759-201-58	IC TC9142P	
C911	1-124-779-00	ELECT CHIP 10uF 20% 16v < DIODE >				< RESISTOR >	
H901	8-719-403-79	DIODE OH009		R951	1-249-413-11	CARBON 470 5% 1/4W	
H902	8-719-403-79	DIODE OH009		R952	1-249-413-11	CARBON 470 5% 1/4W	
H903	8-719-403-79	DIODE OH009 < IC >		R953	1-247-881-00	CARBON 120K 5% 1/4W	
IC902	8-752-017-40	IC CX20174 < RESISTOR >		R954	1-247-881-00	CARBON 120K 5% 1/4W	
				R955	1-249-429-11	CARBON 10K 5% 1/4W	
R907	1-216-242-00	METAL GLAZE 68K 5% 1/8W		R956	1-249-417-11	CARBON 1K 5% 1/4W	
R908	1-216-246-00	METAL GLAZE 100K 5% 1/8W		R957	1-249-417-11	CARBON 1K 5% 1/4W	
R909	1-216-246-00	METAL GLAZE 100K 5% 1/8W		R958	1-247-891-00	CARBON 330K 5% 1/4W	
R910	1-216-238-00	METAL GLAZE 47K 5% 1/8W		R959	1-247-901-11	CARBON 820K 5% 1/4W	
R911	1-216-182-00	METAL GLAZE 220 5% 1/8W		R960	1-249-441-11	CARBON 100K 5% 1/4W	
R912	1-216-182-00	METAL GLAZE 220 5% 1/8W				< VIBRATOR >	
R913	1-216-150-00	METAL GLAZE 10 5% 1/8W		X951	1-577-615-11	VIBRATOR, CRYSTAL	
R914	1-216-150-00	METAL GLAZE 10 5% 1/8W				*****	
R915	1-216-150-00	METAL GLAZE 10 5% 1/8W				* 1-632-740-11 MD BOARD	

						3-356-631-01 HOLDER (SENSOR)	
						< CONNECTOR >	
	* 1-632-746-11	COMPARATOR BOARD ***** < CAPACITOR >		CN1001	1-506-615-11	PIN, CONNECTOR 9P	
C951	1-136-157-00	FILM 0.022uF 5% 50V		CN1002	1-564-501-11	PIN, CONNECTOR 8P	
C952	1-124-282-00	ELECT 22uF 20% 25V				< IC >	
C953	1-124-478-11	ELECT 100uF 20% 25V		IC1001	8-749-920-97	DIODE GP2S22B	
C954	1-124-477-11	ELECT 47uF 20% 25V		IC1002	8-749-920-97	DIODE GP2S22B	
C955	1-162-203-31	CERAMIC 15PF 5% 50V					

MD

MAIN

Ref. No.	Part No.	Description	Remarks	Ref. No.	Part No.	Description	Remarks
		< RESISTOR >					
R1001	1-249-408-11	CARBON 180 5%	1/4W	C126	1-123-382-00	ELECT 3.3uF	20% 100V
R1002	1-249-408-11	CARBON 180 5%	1/4W	C171	1-126-049-11	ELECT 22uF	20% 50V
		< SWITCH >		C172	1-126-049-11	ELECT 22uF	20% 50V
S1002	1-570-953-11	SWITCH, PUSH (1 KEY) (DOOR)		C173	1-126-049-11	ELECT 22uF	20% 50V
S1003	1-571-958-11	SWITCH, PUSH (1 KEY) (CLOSE)		C174	1-126-049-11	ELECT 22uF	20% 50V
S1004	1-572-126-11	SWITCH, PUSH (1 KEY) (OPEN)		C201	1-110-340-11	MYLAR 270PF	5% 50V
S1005	1-572-125-11	SWITCH, LEAF (FWD)		C203	1-136-157-00	FILM 0.022uF	5% 50V
S1006	1-572-202-11	SWITCH, LEAF (HALF)		C207	1-136-159-00	FILM 0.033uF	5% 50V
S1007	1-572-125-11	SWITCH, LEAF (METAL)		C208	1-102-966-00	CERAMIC 43PF	5% 50V
S1008	1-572-125-11	SWITCH, LEAF (70 μ)		C209	1-130-474-00	MYLAR 0.0018uF	5% 50V
		< TERMINAL >		C210	1-130-474-00	MYLAR 0.0018uF	5% 50V
TB1001 *	1-694-018-11	TERMINAL (5P)		C211	1-130-475-00	MYLAR 0.0022uF	5% 50V
*****				C212	1-130-475-00	MYLAR 0.0022uF	5% 50V
* A-2006-780-A	MAIN BOARD, COMPLATE			C213	1-130-478-00	MYLAR 0.0039uF	5% 50V
	*****			C214	1-136-173-00	FILM 0.47uF	5% 50V
	(includin AA)			C215	1-136-167-00	FILM 0.15uF	5% 50V
* 1-533-213-31	HOLDER, FUSE			C216	1-136-155-00	FILM 0.015uF	5% 50V
* 1-560-242-91	BUS BAR 10P			C217	1-124-903-11	ELECT 1uF	20% 50V
7-682-147-15	SCREW, TR			C218	1-136-169-00	FILM 0.22uF	5% 50V
4-902-345-01	HEAT SINK			C219	1-136-163-00	FILM 0.068uF	5% 50V
* 3-309-144-21	HEAT SINK			C220	1-136-162-00	FILM 0.056uF	5% 50V
* 3-356-925-01	HEAT SINK			C221	1-124-903-11	ELECT 1uF	20% 50V
4-870-539-00	PLATE, GROUND			C222	1-130-480-00	MYLAR 0.0056uF	5% 50V
* 4-880-403-11	HEAT SINK			C223	1-136-153-00	FILM 0.01uF	5% 50V
7-682-548-09	SCREW +B 3X8			C225	1-124-925-11	ELECT 2.2uF	20% 100V
7-682-547-04	SCREW +BVT 3X6 (S)			C226	1-123-382-00	ELECT 3.3uF	20% 100V
	< CAPACITOR >			C271	1-126-049-11	ELECT 22uF	20% 50V
C101	1-110-340-11	MYLAR 270PF	5% 50V	C272	1-126-049-11	ELECT 22uF	20% 50V
C103	1-136-157-00	FILM 0.022uF	5% 50V	C273	1-126-049-11	ELECT 22uF	20% 50V
C107	1-136-159-00	FILM 0.033uF	5% 50V	C274	1-126-049-11	ELECT 22uF	20% 50V
C108	1-102-966-00	CERAMIC 43PF	5% 50V	C301	1-126-163-11	ELECT 4.7uF	20% 50V
C109	1-130-474-00	MYLAR 0.0018uF	5% 50V	C302	1-126-163-11	ELECT 4.7uF	20% 50V
C110	1-130-474-00	MYLAR 0.0018uF	5% 50V	C303	1-126-163-11	ELECT 4.7uF	20% 50V
C111	1-130-475-00	MYLAR 0.0022uF	5% 50V	C304	1-130-475-00	MYLAR 0.0022uF	5% 50V
C112	1-130-475-00	MYLAR 0.0022uF	5% 50V	C305	1-130-475-00	MYLAR 0.0022uF	5% 50V
C113	1-130-478-00	MYLAR 0.0039uF	5% 50V	C306	1-130-478-00	MYLAR 0.0039uF	5% 50V
C114	1-136-173-00	FILM 0.47uF	5% 50V	C307	1-136-173-00	FILM 0.47uF	5% 50V
C115	1-136-167-00	FILM 0.15uF	5% 50V	C308	1-136-167-00	FILM 0.15uF	5% 50V
C116	1-136-155-00	FILM 0.015uF	5% 50V	C309	1-136-155-00	FILM 0.015uF	5% 50V
C117	1-124-903-11	ELECT 1uF	20% 50V	C310	1-124-903-11	ELECT 1uF	20% 50V
C118	1-136-169-00	FILM 0.22uF	5% 50V	C311	1-136-169-00	FILM 0.22uF	5% 50V
C119	1-136-163-00	FILM 0.068uF	5% 50V	C312	1-136-162-00	FILM 0.056uF	5% 50V
C120	1-136-162-00	FILM 0.056uF	5% 50V	C313	1-124-903-11	ELECT 1uF	20% 50V
C121	1-124-903-11	ELECT 1uF	20% 50V	C314	1-136-163-00	FILM 0.068uF	5% 50V
C122	1-130-480-00	MYLAR 0.0056uF	5% 50V	C315	1-130-480-00	MYLAR 0.0056uF	5% 50V
C123	1-136-153-00	FILM 0.01uF	5% 50V	C316	1-136-153-00	FILM 0.01uF	5% 50V
C125	1-136-165-00	FILM 0.1uF	5% 50V	C317	1-126-059-11	ELECT 10uF	20% 50V
				C318	1-126-059-11	ELECT 10uF	20% 50V
				C319	1-130-474-00	MYLAR 0.0018uF	5% 50V
				C320	1-126-059-11	ELECT 10uF	20% 50V
				C321	1-136-161-00	FILM 0.047uF	5% 50V
				C322	1-126-049-11	ELECT 22uF	20% 50V
				C323	1-110-338-51	MYLAR 180PF	5% 50V
				C324	1-136-935-11	FILM 22PF	5% 630V
				C325	1-136-155-00	FILM 0.015uF	5% 50V

Ref. No.	Part No.	Description	Remarks			Ref. No.	Part No.	Description	Remarks		
C326	1-136-155-00	FILM	0.015uF	5%	50V	C554	1-130-474-00	MYLAR	0.0018uF	5%	50V
C327	1-136-156-00	FILM	0.018uF	5%	50V	C555	1-124-925-11	ELECT	2.2uF	20%	100V
C328	1-136-155-00	FILM	0.015uF	5%	50V	C556	1-136-228-11	FILM	0.0012uF	5%	100V
C329	1-136-156-00	FILM	0.018uF	5%	50V	C557	1-136-233-11	FILM	0.0047uF	5%	100V
C330	1-136-433-11	FILM	100PF	5%	630V	C558	1-136-228-11	FILM	0.0012uF	5%	100V
C331	1-136-803-11	FILM	560PF	5%	630V	C559	1-124-907-11	ELECT	10uF	20%	50V
C332	1-130-468-00	MYLAR	560PF	5%	50V	C560	1-124-925-11	ELECT	2.2uF	20%	100V
C333	1-136-153-00	FILM	0.01uF	5%	50V	C561	1-136-559-11	FILM	0.0047uF	5%	630V
C334	1-136-157-00	FILM	0.022uF	5%	50V	C562	1-124-907-11	ELECT	10uF	20%	50V
C335	1-136-165-00	FILM	0.1uF	5%	50V	C563	1-107-045-00	MICA	3.9PF		500V
C401	1-126-163-11	ELECT	4.7uF	20%	50V	C564	1-126-059-11	ELECT	10uF	20%	50V
C402	1-126-163-11	ELECT	4.7uF	20%	50V	C565	1-124-477-11	ELECT	47uF	20%	25V
C403	1-126-163-11	ELECT	4.7uF	20%	50V	C591	1-162-282-31	CERAMIC	100PF	10%	50V
C404	1-130-475-00	MYLAR	0.0022uF	5%	50V	C598	1-161-494-00	CERAMIC	0.022uF		25V
C405	1-130-475-00	MYLAR	0.0022uF	5%	50V	C601	1-124-636-00	ELECT	3300uF	20%	25V
C406	1-130-478-00	MYLAR	0.0039uF	5%	50V	C602	1-124-636-00	ELECT	3300uF	20%	25V
C407	1-136-173-00	FILM	0.47uF	5%	50V	C603	1-124-922-11	ELECT	1000uF	20%	63V
C408	1-136-167-00	FILM	0.15uF	5%	50V	C604	1-124-922-11	ELECT	1000uF	20%	63V
C409	1-136-155-00	FILM	0.015uF	5%	50V	C607	1-124-130-00	ELECT	100uF	20%	63V
C410	1-124-903-11	ELECT	1uF	20%	50V	C701	1-124-887-00	ELECT	3300uF	20%	16V
C411	1-136-169-00	FILM	0.22uF	5%	50V	C702	1-124-471-00	ELECT	1000uF	20%	6.3V
C412	1-136-162-00	FILM	0.056uF	5%	50V	C703	1-124-927-11	ELECT	4.7uF	20%	100V
C413	1-124-903-11	ELECT	1uF	20%	50V	C704	1-126-105-11	ELECT	1000uF	20%	35V
C414	1-136-163-00	FILM	0.068uF	5%	50V	C705	1-124-473-11	ELECT	1000uF	20%	10V
C415	1-130-480-00	MYLAR	0.0056uF	5%	50V	C706	1-124-927-11	ELECT	4.7uF	20%	100V
C416	1-136-153-00	FILM	0.01uF	5%	50V	C707	1-124-927-11	ELECT	4.7uF	20%	100V
C417	1-126-059-11	ELECT	10uF	20%	50V	C708	1-126-955-11	ELECT	4700uF	20%	35V
C418	1-126-059-11	ELECT	10uF	20%	50V	C709	1-124-556-11	ELECT	2200uF	20%	16V
C419	1-130-474-00	MYLAR	0.0018uF	5%	50V	C710	1-124-927-11	ELECT	4.7uF	20%	100V
C420	1-126-059-11	ELECT	10uF	20%	50V	C711	1-124-122-11	ELECT	100uF	20%	50V
C421	1-136-161-00	FILM	0.047uF	5%	50V	C712	1-124-477-11	ELECT	47uF	20%	25V
C422	1-126-049-11	ELECT	22uF	20%	50V	C713	1-164-159-11	CERAMIC	0.1uF		50V
C423	1-110-338-51	MYLAR	180PF	5%	50V	C714	1-124-927-11	ELECT	4.7uF	20%	100V
C424	1-136-935-11	FILM	22PF	5%	630V	C801	1-124-443-00	ELECT	100uF	20%	10V
C425	1-136-155-00	FILM	0.015uF	5%	50V	C802	1-124-472-11	ELECT	470uF	20%	10V
C426	1-136-155-00	FILM	0.015uF	5%	50V	C803	1-124-477-11	ELECT	47uF	20%	25V
C427	1-136-156-00	FILM	0.018uF	5%	50V	C804	1-124-927-11	ELECT	4.7uF	20%	100V
C428	1-136-155-00	FILM	0.015uF	5%	50V	C805	1-124-907-11	ELECT	10uF	20%	50V
C429	1-136-156-00	FILM	0.018uF	5%	50V	C806	1-164-159-11	CERAMIC	0.1uF		50V
C430	1-136-433-11	FILM	100PF	5%	630V	C807	1-164-159-11	CERAMIC	0.1uF		50V
C431	1-136-803-11	FILM	560PF	5%	630V			< CONNECTOR >			
C432	1-130-468-00	MYLAR	560PF	5%	50V	CN501	* 1-560-062-00	PIN, CONNECTOR	4P		
C433	1-136-153-00	FILM	0.01uF	5%	50V	CN502	* 1-564-666-11	PIN, CONNECTOR	10P		
C434	1-136-157-00	FILM	0.022uF	5%	50V	CN503	* 1-560-063-00	PIN, CONNECTOR	5P		
C435	1-136-165-00	FILM	0.1uF	5%	50V	CN551	* 1-564-510-11	PLUG, CONNECTOR	7P		
C501	1-130-475-00	MYLAR	0.0022uF	5%	50V	CN553	* 1-564-507-11	PLUG, CONNECTOR	4P		
C502	1-136-165-00	FILM	0.1uF	5%	50V						
C503	1-124-902-00	ELECT	0.47uF	20%	50V	CN555	* 1-564-509-11	PLUG, CONNECTOR	6P		
C505	1-124-907-11	ELECT	10uF	20%	50V	CN556	* 1-560-062-00	PIN, CONNECTOR	4P		
C506	1-124-925-11	ELECT	2.2uF	20%	100V	CN557	* 1-560-061-00	PIN, CONNECTOR	3P		
C507	1-124-925-11	ELECT	2.2uF	20%	100V	CN701	* 1-564-514-11	PLUG, CONNECTOR	11P		
C508	1-124-477-11	ELECT	47uF	20%	25V	CN801	* 1-564-666-11	PIN, CONNECTOR	10P		
C551	1-136-157-00	FILM	0.022uF	5%	50V						
C552	1-136-157-00	FILM	0.022uF	5%	50V	CN802	* 1-564-342-11	PIN, CONNECTOR	8P		
C553	1-130-474-00	MYLAR	0.0018uF	5%	50V	CN803	* 1-564-336-00	PIN, CONNECTOR	2P		



MAIN

Ref. No.	Part No.	Description	Remarks	Ref. No.	Part No.	Description	Remarks
		< COMPOSITION >					
CP801	1-236-984-11	COMPOSITION CIRCUIT BLOCK		IC506	8-759-634-50	IC M5218AL	
		< DIODE >		IC507	8-759-634-50	IC M5218AL	
D101	8-719-987-63	DIODE 1N4148M		IC551	8-759-945-58	IC RC4558P	
D102	8-719-000-54	DIODE UZL-6L3		IC552	8-752-018-80	IC CX20188	
D103	8-719-987-63	DIODE 1N4148M		IC553	8-759-710-59	IC NJM4580D-D	
D104	8-719-987-63	DIODE 1N4148M		IC554	8-759-106-56	IC uPC1297CA	
D201	8-719-987-63	DIODE 1N4148M		IC555	8-759-634-50	IC M5218AL	
D202	8-719-000-54	DIODE UZL-6L3		IC801	8-759-635-69	IC M50964-226SP	
D203	8-719-987-63	DIODE 1N4148M		IC802	8-759-973-95	IC BA6219B	
D204	8-719-987-63	DIODE 1N4148M		IC803	8-759-822-09	IC LB1641	
D501	8-719-987-63	DIODE 1N4148M				< JACK >	
D502	8-719-987-63	DIODE 1N4148M		J501	1-565-320-61	JACK, PIN 6P (CD/LINE)	
D503	8-719-987-63	DIODE 1N4148M				< COIL >	
D504	8-719-987-63	DIODE 1N4148M		L101	1-410-778-11	INDUCTOR 18mH	
D505	8-719-987-63	DIODE 1N4148M		L201	1-410-778-11	INDUCTOR 18mH	
D506	8-719-987-63	DIODE 1N4148M		L301	1-410-771-11	INDUCTOR 4.7mH	
D507	8-719-987-63	DIODE 1N4148M		L302	1-410-769-31	INDUCTOR 3.3mH	
D509	8-719-987-63	DIODE 1N4148M		L303	1-410-767-11	INDUCTOR 2.2mH	
D551	8-719-987-63	DIODE 1N4148M		L304	1-410-780-11	INDUCTOR 27mH	
D552	8-719-987-63	DIODE 1N4148M		L401	1-410-771-11	INDUCTOR 4.7mH	
D553	8-719-987-63	DIODE 1N4148M		L402	1-410-769-31	INDUCTOR 3.3mH	
D554	8-719-987-63	DIODE 1N4148M		L403	1-410-767-11	INDUCTOR 2.2mH	
D555	8-719-987-63	DIODE 1N4148M		L404	1-410-780-11	INDUCTOR 27mH	
D556	8-719-987-63	DIODE 1N4148M				< FILTER >	
D601	8-719-230-02	DIODE 30DF2		LPF301	1-236-087-11	FILTER, LOW PASS	
D602	8-719-230-02	DIODE 30DF2		LPF401	1-236-087-11	FILTER, LOW PASS	
D603	8-719-230-02	DIODE 30DF2				< PILOT LAMP >	
D604	8-719-230-02	DIODE 30DF2		PL551	1-518-471-31	LAMP, PILOT	
D605	8-719-933-41	DIODE HZS6C3L		PL552	1-518-471-31	LAMP, PILOT	
D701	8-719-200-77	DIODE 10E2N				< TRANSISTOR >	
D702	8-719-200-77	DIODE 10E2N		Q106	8-729-922-37	TRANSISTOR 2SD2144S	
D703	8-719-200-77	DIODE 10E2N		Q107	8-729-922-37	TRANSISTOR 2SD2144S	
D704	8-719-200-77	DIODE 10E2N		Q108	8-729-922-37	TRANSISTOR 2SD2144S	
D705	8-719-200-77	DIODE 10E2N		Q206	8-729-922-37	TRANSISTOR 2SD2144S	
D706	8-719-200-77	DIODE 10E2N		Q207	8-729-922-37	TRANSISTOR 2SD2144S	
D707	8-719-200-77	DIODE 10E2N		Q208	8-729-922-37	TRANSISTOR 2SD2144S	
D708	8-719-933-41	DIODE HZS6C3L		Q301	8-729-922-37	TRANSISTOR 2SD2144S	
D712	8-719-933-41	DIODE HZS6C3L		Q302	8-729-922-37	TRANSISTOR 2SD2144S	
D713	8-719-001-79	DIODE UZL-12H1		Q303	8-729-922-37	TRANSISTOR 2SD2144S	
D714	8-719-015-02	DIODE UZP-8.2BB		Q304	8-729-922-37	TRANSISTOR 2SD2144S	
D715	8-719-200-77	DIODE 10E2N		Q305	8-729-922-37	TRANSISTOR 2SD2144S	
D716	8-719-987-63	DIODE 1N4148M		Q401	8-729-922-37	TRANSISTOR 2SD2144S	
D801	8-719-200-77	DIODE 10E2N		Q402	8-729-922-37	TRANSISTOR 2SD2144S	
D802	8-719-987-63	DIODE 1N4148M		Q403	8-729-922-37	TRANSISTOR 2SD2144S	
D803	8-719-987-63	DIODE 1N4148M		Q404	8-729-922-37	TRANSISTOR 2SD2144S	
		< IC >		Q405	8-729-922-37	TRANSISTOR 2SD2144S	
IC501	8-759-602-01	IC M5220P		Q501	8-729-922-37	TRANSISTOR 2SD2144S	
IC502	8-752-018-80	IC CX20188		Q502	8-729-922-37	TRANSISTOR 2SD2144S	
IC503	8-759-000-49	IC MC14066BCP		Q503	8-729-900-89	TRANSISTOR DTC144ES	
IC504	8-759-945-58	IC RC4558P		Q504	8-729-900-80	TRANSISTOR DTC114ES	
IC505	8-759-634-50	IC M5218AL					

Ref. No.	Part No.	Description	Remarks	Ref. No.	Part No.	Description	Remarks
Q505	8-729-900-89	TRANSISTOR DTC144ES		R119	1-247-719-11	CARBON 3.3K	5% 1/4W
Q551	8-729-194-57	TRANSISTOR 2SC945-P		R120	1-246-545-00	CARBON 1.0M	5% 1/4W
Q552	8-729-194-57	TRANSISTOR 2SC945-P		R121	1-247-710-11	CARBON 560	5% 1/4W
Q553	8-729-281-52	TRANSISTOR 2SC1815-Y		R122	1-249-462-11	CARBON 22K	5% 1/4W
Q554	8-729-900-80	TRANSISTOR DTC144ES		R123	1-247-852-11	CARBON 7.5K	5% 1/4W
Q555	8-729-900-61	TRANSISTOR DTA114ES		R124	1-249-415-11	CARBON 680	5% 1/4W
Q556	8-729-900-80	TRANSISTOR DTC144ES		R125	1-247-854-11	CARBON 9.1K	5% 1/4W
Q557	8-729-900-80	TRANSISTOR DTC144ES		R126	1-249-465-11	CARBON 47K	5% 1/4W
Q558	8-729-900-80	TRANSISTOR DTC144ES		R127	1-249-465-11	CARBON 47K	5% 1/4W
Q559	8-729-900-89	TRANSISTOR DTC144ES		R128	1-249-681-11	CARBON 2.2K	5% 1/2W
Q560	8-729-900-89	TRANSISTOR DTC144ES		R129	1-249-673-11	CARBON 1K	5% 1/2W
Q601	8-729-141-89	TRANSISTOR 2SD1585-LK		R130	1-249-461-11	CARBON 18K	5% 1/4W
Q602	8-729-141-83	TRANSISTOR 2SB1094-LK		R131	1-249-421-11	CARBON 2.2K	5% 1/4W
Q603	8-729-922-37	TRANSISTOR 2SD2144S		R132	1-249-429-11	CARBON 10K	5% 1/4W
Q604	8-729-224-62	TRANSISTOR 2SK246-GR		R133	1-249-433-11	CARBON 22K	5% 1/4W
Q605	8-729-141-32	TRANSISTOR 2SA1409-LK		R134	1-249-417-11	CARBON 1K	5% 1/4W
Q606	8-729-224-62	TRANSISTOR 2SK246-GR		R135	1-249-437-11	CARBON 47K	5% 1/4W
Q607	8-729-620-05	TRANSISTOR 2SC2603-EF		R136	1-249-427-11	CARBON 6.8K	5% 1/4W
Q611	8-729-119-76	TRANSISTOR 2SA1175-HFE		R137	1-249-427-11	CARBON 6.8K	5% 1/4W
Q701	8-729-209-15	TRANSISTOR 2SD2012		R138	1-215-465-00	METAL 68K	1% 1/6W
Q702	8-729-209-15	TRANSISTOR 2SD2012		R139	1-215-448-00	METAL 13K	1% 1/6W
Q703	8-729-209-15	TRANSISTOR 2SD2012		R140	1-215-471-00	METAL 120K	1% 1/6W
Q704	8-729-620-05	TRANSISTOR 2SC2603-EF		R141	1-249-408-11	CARBON 180	5% 1/4W
Q706	8-729-922-37	TRANSISTOR 2SD2144S		R142	1-247-883-00	CARBON 150K	5% 1/4W
Q707	8-729-620-05	TRANSISTOR 2SC2603-EF		R143	1-249-429-11	CARBON 10K	5% 1/4W
Q708	8-729-922-37	TRANSISTOR 2SD2144S		R201	1-249-721-11	CARBON 100K	5% 1/2W
Q709	8-729-140-04	TRANSISTOR 2SB1116A-L		R202	1-247-740-11	CARBON 120	5% 1/2W
Q710	8-729-141-32	TRANSISTOR 2SA1409-LK		R204	1-249-724-91	CARBON 130K	5% 1/2W
Q801	8-729-900-65	TRANSISTOR DTA144ES		R205	1-247-761-11	CARBON 5.6K	5% 1/2W
Q802	8-729-900-65	TRANSISTOR DTA144ES		R213	1-247-717-11	CARBON 2.2K	5% 1/4W
Q803	8-729-900-65	TRANSISTOR DTA144ES		R214	1-247-138-00	CARBON 2K	5% 1/4W
Q804	8-729-900-65	TRANSISTOR DTA144ES		R215	1-247-720-11	CARBON 3.9K	5% 1/4W
Q805	8-729-119-76	TRANSISTOR 2SA1175-HFE		R216	1-247-710-11	CARBON 560	5% 1/4W
Q806	8-729-900-65	TRANSISTOR DTA144ES		R217	1-247-725-11	CARBON 10K	5% 1/4W
Q807	8-729-900-65	TRANSISTOR DTA144ES		R218	1-247-719-11	CARBON 3.3K	5% 1/4W
Q808	8-729-119-76	TRANSISTOR 2SA1175-HFE		R219	1-247-719-11	CARBON 3.3K	5% 1/4W
Q809	8-729-900-65	TRANSISTOR DTA144ES		R220	1-246-545-00	CARBON 1.0M	5% 1/4W
Q810	8-729-119-76	TRANSISTOR 2SA1175-HFE		R221	1-247-710-11	CARBON 560	5% 1/4W
Q811	8-729-119-76	TRANSISTOR 2SA1175-HFE		R222	1-249-462-11	CARBON 22K	5% 1/4W
Q812	8-729-900-61	TRANSISTOR DTA114ES		R223	1-247-852-11	CARBON 7.5K	5% 1/4W
Q813	8-729-620-05	TRANSISTOR 2SC2603-EF		R224	1-249-415-11	CARBON 680	5% 1/4W
Q814	8-729-620-05	TRANSISTOR 2SC2603-EF		R225	1-247-854-11	CARBON 9.1K	5% 1/4W
		< RESISTOR >		R226	1-249-465-11	CARBON 47K	5% 1/4W
R101	1-249-721-11	CARBON 100K	5% 1/2W	R227	1-249-465-11	CARBON 47K	5% 1/4W
R102	1-247-740-11	CARBON 1201	5% 1/2W	R228	1-249-681-11	CARBON 2.2K	5% 1/2W
R104	1-249-724-91	CARBON 130K	5% 1/2W	R229	1-249-673-11	CARBON 1K	5% 1/2W
R105	1-247-761-11	CARBON 5.6K	5% 1/2W	R230	1-249-461-11	CARBON 18K	5% 1/4W
R113	1-247-717-11	CARBON 2.2K	5% 1/4W	R231	1-249-421-11	CARBON 2.2K	5% 1/4W
R114	1-247-138-00	CARBON 2K	5% 1/4W	R232	1-249-429-11	CARBON 10K	5% 1/4W
R115	1-247-720-11	CARBON 3.9K	5% 1/4W	R233	1-249-433-11	CARBON 22K	5% 1/4W
R116	1-247-710-11	CARBON 560	5% 1/4W	R234	1-249-417-11	CARBON 1K	5% 1/4W
R117	1-247-725-11	CARBON 10K	5% 1/4W	R235	1-249-437-11	CARBON 47K	5% 1/4W
R118	1-247-719-11	CARBON 3.3K	5% 1/4W	R236	1-249-427-11	CARBON 6.8K	5% 1/4W
				R237	1-215-441-00	METAL 6.8K	1% 1/6W
				R237	1-249-427-11	CARBON 6.8K	5% 1/4W

MAIN

Ref. No.	Part No.	Description	Quantity	Material	Remarks	Ref. No.	Part No.	Description	Quantity	Material	Remarks
R238	1-215-465-00	METAL	68K	1%	1/6W	R405	1-247-720-11	CARBON	3.9K	5%	1/4W
R239	1-215-448-00	METAL	13K	1%	1/6W	R406	1-247-719-11	CARBON	3.3K	5%	1/4W
R240	1-215-471-00	METAL	120K	1%	1/6W	R407	1-247-152-00	CARBON	7.5K	5%	1/4W
R241	1-249-408-11	CARBON	180	5%	1/4W	R408	1-249-465-11	CARBON	47K	5%	1/4W
R242	1-247-883-00	CARBON	150K	5%	1/4W	R409	1-249-465-11	CARBON	47K	5%	1/4W
R243	1-249-429-11	CARBON	10K	5%	1/4W	R410	1-247-128-00	CARBON	750	5%	1/4W
R301	1-249-703-11	CARBON	18K	5%	1/2W	R411	1-247-725-11	CARBON	10K	5%	1/4W
R302	1-249-490-11	CARBON	27K	5%	1/2W	R412	1-247-719-11	CARBON	3.3K	5%	1/4W
R303	1-249-469-11	CARBON	100K	5%	1/4W	R413	1-247-719-11	CARBON	3.3K	5%	1/4W
R304	1-247-723-11	CARBON	6.8K	5%	1/4W	R414	1-246-545-00	CARBON	1.0M	5%	1/4W
R305	1-247-720-11	CARBON	3.9K	5%	1/4W	R415	1-247-710-11	CARBON	560	5%	1/4W
R306	1-247-719-11	CARBON	3.3K	5%	1/4W	R416	1-249-462-11	CARBON	22K	5%	1/4W
R307	1-247-152-00	CARBON	7.5K	5%	1/4W	R417	1-247-854-11	CARBON	9.1K	5%	1/4W
R308	1-249-465-11	CARBON	47K	5%	1/4W	R418	1-247-852-11	CARBON	7.5K	5%	1/4W
R309	1-249-465-11	CARBON	47K	5%	1/4W	R419	1-249-415-11	CARBON	680	5%	1/4W
R310	1-247-128-00	CARBON	750	5%	1/4W	R420	1-249-462-11	CARBON	22K	5%	1/4W
R311	1-247-725-11	CARBON	10K	5%	1/4W	R421	1-247-719-11	CARBON	3.3K	5%	1/4W
R312	1-247-719-11	CARBON	3.3K	5%	1/4W	R422	1-247-723-11	CARBON	6.8K	5%	1/4W
R313	1-247-719-11	CARBON	3.3K	5%	1/4W	R423	1-249-462-11	CARBON	22K	5%	1/4W
R314	1-246-545-00	CARBON	1.0M	5%	1/4W	R424	1-249-465-11	CARBON	47K	5%	1/4W
R315	1-247-710-11	CARBON	560	5%	1/4W	R425	1-247-717-11	CARBON	2.2K	5%	1/4W
R316	1-249-462-11	CARBON	22K	5%	1/4W	R426	1-249-469-11	CARBON	100K	5%	1/4W
R317	1-247-854-11	CARBON	9.1K	5%	1/4W	R427	1-249-593-11	CARBON	51K	5%	1/4W
R318	1-247-852-11	CARBON	7.5K	5%	1/4W	R428	1-247-721-11	CARBON	4.7K	5%	1/4W
R319	1-249-415-11	CARBON	680	5%	1/4W	R429	1-247-703-11	CARBON	180	5%	1/4W
R320	1-249-462-11	CARBON	22K	5%	1/4W	R430	1-247-725-11	CARBON	10K	5%	1/4W
R321	1-247-719-11	CARBON	3.3K	5%	1/4W	R431	1-247-148-00	CARBON	5.1K	5%	1/4W
R322	1-247-723-11	CARBON	6.8K	5%	1/4W	R432	1-247-701-11	CARBON	120	5%	1/4W
R323	1-249-462-11	CARBON	22K	5%	1/4W	R433	1-247-152-00	CARBON	8.2K	5%	1/4W
R324	1-249-465-11	CARBON	47K	5%	1/4W	R434	1-247-720-11	CARBON	3.9K	5%	1/4W
R325	1-247-717-11	CARBON	2.2K	5%	1/4W	R435	1-247-701-11	CARBON	120	5%	1/4W
R326	1-249-469-11	CARBON	100K	5%	1/4W	R436	1-249-429-11	CARBON	10K	5%	1/4W
R327	1-249-593-11	CARBON	51K	5%	1/4W	R437	1-249-429-11	CARBON	10K	5%	1/4W
R328	1-247-721-11	CARBON	4.7K	5%	1/4W	R438	1-249-429-11	CARBON	10K	5%	1/4W
R329	1-247-703-11	CARBON	180	5%	1/4W	R439	1-249-429-11	CARBON	10K	5%	1/4W
R330	1-247-725-11	CARBON	10K	5%	1/4W	R440	1-249-421-11	CARBON	2.2K	5%	1/4W
R331	1-247-148-00	CARBON	5.1K	5%	1/4W	R441	1-249-604-11	CARBON	150K	5%	1/4W
R332	1-247-701-11	CARBON	120	5%	1/4W	R442	△1-212-857-00	FUSIBLE	10	5%	1/4W F
R333	1-247-152-00	CARBON	8.2K	5%	1/4W	R443	1-249-435-11	CARBON	33K	5%	1/4W
R334	1-247-720-11	CARBON	3.9K	5%	1/4W	R444	1-249-426-11	CARBON	5.6K	5%	1/4W
R334	1-247-721-11	CARBON	4.7K	5%	1/4W	R501	1-249-433-11	CARBON	22K	5%	1/4W
R335	1-247-701-11	CARBON	120	5%	1/4W	R502	1-249-433-11	CARBON	22K	5%	1/4W
R336	1-249-429-11	CARBON	10K	5%	1/4W	R503	1-249-469-11	CARBON	100K	5%	1/4W
R337	1-249-429-11	CARBON	10K	5%	1/4W	R504	1-249-465-11	CARBON	47K	5%	1/4W
R338	1-249-429-11	CARBON	10K	5%	1/4W	R505	1-215-472-00	METAL	130K	1%	1/6W
R339	1-249-429-11	CARBON	10K	5%	1/4W	R506	1-249-437-11	CARBON	47K	5%	1/4W
R340	1-249-421-11	CARBON	2.2K	5%	1/4W	R507	1-249-433-11	CARBON	22K	5%	1/4W
R341	1-249-604-11	CARBON	150K	5%	1/4W	R508	1-249-417-11	CARBON	1K	5%	1/4W
R342	△1-212-857-00	FUSIBLE	10	5%	1/4W F	R509	1-247-885-00	CARBON	180K	5%	1/4W
R343	1-249-435-11	CARBON	33K	5%	1/4W	R510	1-249-433-11	CARBON	22K	5%	1/4W
R344	1-249-426-11	CARBON	5.6K	5%	1/4W	R511	1-249-413-11	CARBON	470	5%	1/4W
R401	1-249-703-11	CARBON	18K	5%	1/2W	R512	1-249-413-11	CARBON	470	5%	1/4W
R402	1-249-490-11	CARBON	27K	5%	1/2W	R513	1-249-432-11	CARBON	18K	5%	1/4W
R403	1-249-469-11	CARBON	100K	5%	1/4W	R514	1-249-433-11	CARBON	22K	5%	1/4W
R404	1-247-723-11	CARBON	6.8K	5%	1/4W	R515	1-249-437-11	CARBON	47K	5%	1/4W

Note: The components identified by mark  or dotted line with mark  are critical for safety. Replace only with part number specified.

Ref. No.	Part No.	Description	Remarks	Ref. No.	Part No.	Description	Remarks
R516	1-249-437-11	CARBON	47K 5% 1/4W	R712	1-249-429-11	CARBON	10K 5% 1/4W
R517	1-249-437-11	CARBON	47K 5% 1/4W	R713	1-249-441-11	CARBON	100K 5% 1/4W
R518	1-249-429-11	CARBON	10K 5% 1/4W	R714	1-249-425-11	CARBON	4.7K 5% 1/4W
R519	1-249-429-11	CARBON	10K 5% 1/4W	R715	1-247-752-11	CARBON	1K 5% 1/2W
R520	1-249-437-11	CARBON	47K 5% 1/4W	R801	1-249-429-11	CARBON	10K 5% 1/4W
R521	1-249-429-11	CARBON	10K 5% 1/4W	R802	1-249-429-11	CARBON	10K 5% 1/4W
R522	1-249-437-11	CARBON	47K 5% 1/4W	R803	1-249-440-11	CARBON	82K 5% 1/4W
R523	1-249-421-11	CARBON	2.2K 5% 1/4W	R804	1-249-429-11	CARBON	10K 5% 1/4W
R550	1-215-472-00	METAL	130K 1% 1/6W	R805	1-249-429-11	CARBON	10K 5% 1/4W
R551	1-249-432-11	CARBON	18K 5% 1/4W	R806	1-249-429-11	CARBON	10K 5% 1/4W
R552	1-249-433-11	CARBON	22K 5% 1/4W	R807	1-249-429-11	CARBON	10K 5% 1/4W
R553	1-249-406-11	CARBON	120 5% 1/4W	R808	1-249-421-11	CARBON	2.2K 5% 1/4W
R554	1-249-432-11	CARBON	18K 5% 1/4W	R809	1-249-421-11	CARBON	2.2K 5% 1/4W
R555	1-249-397-11	CARBON	22 5% 1/4W	R810	1-249-429-11	CARBON	10K 5% 1/4W
R556	1-247-856-00	CARBON	11K 5% 1/4W	R811	1-249-435-11	CARBON	33K 5% 1/4W
R557	1-249-429-11	CARBON	10K 5% 1/4W	R812	1-249-429-11	CARBON	10K 5% 1/4W
R558	1-249-406-11	CARBON	120 5% 1/4W	R813	1-249-413-11	CARBON	470 5% 1/4W
R559	1-247-856-00	CARBON	11K 5% 1/4W	R814	1-249-436-11	CARBON	39K 5% 1/4W
R560	1-249-397-11	CARBON	22 5% 1/4W	R815	1-249-436-11	CARBON	39K 5% 1/4W
R561	1-247-887-00	CARBON	220K 5% 1/4W	R816	1-247-903-00	CARBON	1M 5% 1/4W
R562	1-247-887-00	CARBON	220K 5% 1/4W	R817	1-249-425-11	CARBON	4.7K 5% 1/4W
R563	1-249-407-11	CARBON	150 5% 1/4W	R818	1-249-417-11	CARBON	1K 5% 1/4W
R564	1-249-437-11	CARBON	47K 5% 1/4W	R819	1-249-435-11	CARBON	33K 5% 1/4W
R565	1-249-441-11	CARBON	100K 5% 1/4W	R820	1-249-437-11	CARBON	47K 5% 1/4W
R566	1-249-421-11	CARBON	2.2K 5% 1/4W	R821	1-249-484-11	CARBON	6.8 5% 1/2W
R567	1-249-440-11	CARBON	82K 5% 1/4W	R822	1-249-484-11	CARBON	6.8 5% 1/2W
R568	1-249-440-11	CARBON	82K 5% 1/4W	R823	1-247-854-11	CARBON	9.1K 5% 1/4W
R569	△1-212-853-00	FUSIBLE	6.8 5% 1/4W F	R824	1-249-425-11	CARBON	4.7K 5% 1/4W
R570	△1-212-853-00	FUSIBLE	6.8 5% 1/4W F	R825	1-249-425-11	CARBON	4.7K 5% 1/4W
R571	1-249-427-11	CARBON	6.8K 5% 1/4W	R826	1-249-425-11	CARBON	4.7K 5% 1/4W
R572	1-249-381-11	CARBON	1 5% 1/4W	R827	1-249-425-11	CARBON	4.7K 5% 1/4W
R573	1-249-421-11	CARBON	2.2K 5% 1/4W	R828	1-249-426-11	CARBON	5.6K 5% 1/4W
R574	1-249-417-11	CARBON	1K 5% 1/4W	R829	1-249-429-11	CARBON	10K 5% 1/4W
R576	1-249-413-11	CARBON	470 5% 1/4W	R830	1-249-429-11	CARBON	10K 5% 1/4W
R577	1-249-417-11	CARBON	1K 5% 1/4W	R831	1-249-427-11	CARBON	6.8K 5% 1/4W
R578	1-249-421-11	CARBON	2.2K 5% 1/4W	R832	1-249-428-11	CARBON	8.2K 5% 1/4W
R603	1-247-717-11	CARBON	2.2K 5% 1/4W	R833	1-249-429-11	CARBON	10K 5% 1/4W
R604	1-247-717-11	CARBON	2.2K 5% 1/4W	R834	1-249-429-11	CARBON	10K 5% 1/4W
R605	1-247-706-11	CARBON	330 5% 1/4W	R835	1-249-413-11	CARBON	470 5% 1/4W
R606	1-249-556-11	CARBON	1.5K 5% 1/4W				
R607	1-249-556-11	CARBON	1.5K 5% 1/4W			< VARIABLE RESISTOR >	
R608	1-249-926-11	CARBON	1.3K 5% 1/4W	RV101	1-230-504-11	RES, ADJ, METAL 220	
R609	1-247-717-11	CARBON	2.2K 5% 1/4W	RV102	1-238-601-11	RES, ADJ, CARBON 22K	
R611	1-247-704-11	CARBON	220 5% 1/4W	RV201	1-230-504-11	RES, ADJ, METAL 220	
R612	1-247-704-11	CARBON	220 5% 1/4W	RV202	1-238-601-11	RES, ADJ, CARBON 22K	
R701	1-249-421-11	CARBON	2.2K 5% 1/4W	RV301	1-228-993-00	RES, ADJ, METAL 4.7K	
R702	1-249-421-11	CARBON	2.2K 5% 1/4W	RV303	1-238-601-11	RES, ADJ, CARBON 22K	
R703	1-249-421-11	CARBON	2.2K 5% 1/4W	RV401	1-228-993-00	RES, ADJ, METAL 4.7K	
R704	1-249-425-11	CARBON	4.7K 5% 1/4W	RV403	1-238-601-11	RES, ADJ, CARBON 22K	
R706	1-249-425-11	CARBON	4.7K 5% 1/4W	RV551	1-238-595-11	RES, ADJ, CARBON 220	
R707	1-249-421-11	CARBON	2.2K 5% 1/4W	RV552	1-238-595-11	RES, ADJ, CARBON 220	
R708	1-249-421-11	CARBON	2.2K 5% 1/4W	RV553	1-238-599-11	RES, ADJ, CARBON 4.7K	
R709	1-249-427-11	CARBON	6.8K 5% 1/4W	RV554	1-238-601-11	RES, ADJ, CARBON 22K	
R710	1-249-425-11	CARBON	4.7K 5% 1/4W	RV801	1-238-599-11	RES, ADJ, CARBON 4.7K	
R711	1-249-431-11	CARBON	15K 5% 1/4W				

Note: The components identified by mark Δ or dotted line with mark Δ are critical for safety. Replace only with part number specified.

MAIN REEL MOTOR PANEL

Ref. No.	Part No.	Description	Remarks
		< TRANSFORMER >	
T301	1-433-384-11	TRANSFORMER, BIAS OSCILLATOR	
T401	1-433-384-11	TRANSFORMER, BIAS OSCILLATOR	
T551	1-433-359-11	TRANSFORMER, BIAS OSCILLATION	
		< TEST PIN >	
TP551	* 1-564-505-11	PLUG, CONNECTOR 2P	
TP552	* 1-564-506-11	PLUG, CONNECTOR 3P	
TP553	* 1-564-506-11	PLUG, CONNECTOR 3P	
TP801	* 1-564-506-11	PLUG, CONNECTOR 3P	
		< VIBRATOR >	
X801	1-577-358-21	VIBRATOR, CERAMIC (4MHz)	

	* 1-632-741-11	REEL MOTOR BOARD	

		< CAPACITOR >	
C1051	1-124-907-11	ELECT 10uF 20% 50V	
C1052	1-124-907-11	ELECT 10uF 20% 50V	
C1053	1-164-159-11	CERAMIC 0.1uF 50V	
		< CONNECTOR >	
CN1051	* 1-564-499-11	PIN, CONNECTOR 6P	
CN1052	* 1-564-718-11	PIN, CONNECTOR (SMALL TYPE) 2P	
CN1053	* 1-564-718-11	PIN, CONNECTOR (SMALL TYPE) 2P	
		< RESISTOR >	
R1051	1-249-412-11	CARBON 390 5% 1/4W	

	* A-2006-781-A	PANEL BOARD, COMPLETE	

		(includink ●A-G)	
		< CAPACITOR >	
C001	1-161-744-00	CERAMIC 0.01uF 400V	
C181	1-126-059-11	ELECT 10uF 20% 50V	
C281	1-126-059-11	ELECT 10uF 20% 50V	
C341	1-130-473-00	MYLAR 0.0015uF 5% 50V	
C342	1-130-471-00	MYLAR 0.001uF 5% 50V	
C441	1-130-473-00	MYLAR 0.0015uF 5% 50V	
C442	1-130-471-00	MYLAR 0.001uF 5% 50V	
C541	1-123-369-00	ELECT 4.7uF 20% 50V	
C542	1-123-369-00	ELECT 4.7uF 20% 50V	
C597	1-161-494-00	CERAMIC 0.022uF 25V	
C901	1-126-177-11	ELECT 100uF 20% 10V	
		< CONNECTOR >	
CN001	* 1-568-226-11	PIN, CONNECTOR 2P	
CN002	1-568-226-11	PIN, CONNECTOR 2P	

Ref. No.	Part No.	Description	Remarks
CN521	* 1-564-521-11	PLUG, CONNECTOR 6P	
CN543	* 1-560-070-00	BASE POST 5P	
CN591	* 1-564-519-11	PLUG, CONNECTOR 4P	
CN592	* 1-564-519-11	PLUG, CONNECTOR 4P	
CN593	* 1-564-519-11	PLUG, CONNECTOR 4P	
CN901	* 1-564-336-00	PIN, CONNECTOR 2P	
		< COMPOSITION >	
CP901	1-232-881-11	COMPOSITION CIRCUIT BLOCK	
CP902	1-232-881-11	COMPOSITION CIRCUIT BLOCK	
CP903	1-236-985-11	COMPOSITION CIRCUIT BLOCK	
		< DIODE >	
D901	8-719-987-63	DIODE IN4148M	
D902	8-719-987-63	DIODE IN4148M	
D903	8-719-933-57	DIODE HZS9B2L	
D904	8-719-987-63	DIODE IN4148M	
D905	8-719-987-63	DIODE IN4148M	
D906	8-719-987-63	DIODE IN4148M	
D907	8-719-987-63	DIODE IN4148M	
D908	8-719-987-63	DIODE IN4148M	
D909	8-719-987-63	DIODE IN4148M	
D910	8-719-987-63	DIODE IN4148M	
D911	8-719-987-63	DIODE IN4148M	
D912	8-719-302-46	DIODE SEL1210S-C(REC)	
D913	8-719-302-45	DIODE SEL1210S (▲)	
D914	8-719-302-79	DIODE SEL1910A-C (PAUSE)	
		< FILTER >	
FLT901	1-519-560-21	INDICATOR TUBE, FLUORESCENT	
		< IC >	
IC541	8-759-634-51	IC M5218AP	
IC901	8-759-635-68	IC M50940-313SP	
IC902	8-741-100-48	IC SBX1610-59	
		< JACK >	
J541	1-507-796-71	JACK (HEADPHONES)	
		< TRANSISTOR >	
Q901	8-729-115-28	TRANSISTOR BN1L3Z-K	
Q902	8-729-119-76	TRANSISTOR 2SA1175-HFE	
Q903	8-729-900-61	TRANSISTOR DTA114ES	
Q904	8-729-900-61	TRANSISTOR DTA114ES	
Q905	8-729-900-61	TRANSISTOR DTA114ES	
Q906	8-729-900-61	TRANSISTOR DTA114ES	
Q907	8-729-900-65	TRANSISTOR DTA144ES	
Q908	8-729-900-65	TRANSISTOR DTA144ES	
Q909	8-729-900-65	TRANSISTOR DTA144ES	
Q910	8-729-900-65	TRANSISTOR DTA144ES	
Q911	8-729-900-89	TRANSISTOR DTC144ES	
Q912	8-729-900-65	TRANSISTOR DTA144ES	
Q913	8-729-900-65	TRANSISTOR DTA144ES	
Q914	8-729-900-65	TRANSISTOR DTA144ES	

PANEL

Ref. No.	Part No.	Description	Remarks
Q915	8-729-900-89	TRANSISTOR DTC144ES	
Q916	8-729-900-65	TRANSISTOR DTA144ES	
Q917	8-729-900-65	TRANSISTOR DTA144ES	
Q918	8-729-119-76	TRANSISTOR 2SA1175-HFE	
Q919	8-729-900-65	TRANSISTOR DTA144ES	
< RESISTOR >			
R001	1-247-752-11	CARBON 1K	5% 1/2W
R181	1-249-429-11	CARBON 10K	5% 1/4W
R182	1-249-433-11	CARBON 22K	5% 1/4W
R183	1-249-423-11	CARBON 3.3K	5% 1/4W
R184	1-247-704-11	CARBON 220	5% 1/4W
R281	1-249-429-11	CARBON 10K	5% 1/4W
R282	1-249-434-11	CARBON 27K	5% 1/4W
R283	1-249-423-11	CARBON 3.3K	5% 1/4W
R284	1-247-704-11	CARBON 220	5% 1/4W
R381	1-247-721-11	CARBON 4.7K	5% 1/4W
R382	1-247-152-00	CARBON 8.2K	5% 1/4W
R383	1-247-725-11	CARBON 10K	5% 1/4W
R384	1-247-721-11	CARBON 4.7K	5% 1/4W
R385	1-246-545-00	CARBON 1.0M	5% 1/4W
R386	1-249-462-11	CARBON 22K	5% 1/4W
R481	1-247-721-11	CARBON 4.7K	5% 1/4W
R482	1-247-152-00	CARBON 8.2K	5% 1/4W
R483	1-247-725-11	CARBON 10K	5% 1/4W
R484	1-247-721-11	CARBON 4.7K	5% 1/4W
R485	1-246-545-00	CARBON 1.0M	5% 1/4W
R486	1-249-462-11	CARBON 22K	5% 1/4W
R590	1-249-429-11	CARBON 10K	5% 1/4W
R881	1-249-434-11	CARBON 27K	5% 1/4W
R882	1-249-431-11	CARBON 15K	5% 1/4W
R901	1-249-421-11	CARBON 2.2K	5% 1/4W
R902	1-249-421-11	CARBON 2.2K	5% 1/4W
R903	1-247-895-00	CARBON 470K	5% 1/4W
R904	1-249-433-11	CARBON 22K	5% 1/4W
R905	1-249-433-11	CARBON 22K	5% 1/4W
R906	1-249-429-11	CARBON 10K	5% 1/4W
R907	1-249-425-11	CARBON 4.7K	5% 1/4W
R908	1-249-431-11	CARBON 15K	5% 1/4W
R909	1-249-422-11	CARBON 2.7K	5% 1/4W
R910	1-249-424-11	CARBON 3.9K	5% 1/4W
R911	1-249-428-11	CARBON 8.2K	5% 1/4W
R912	1-249-434-11	CARBON 27K	5% 1/4W
R913	1-249-422-11	CARBON 2.7K	5% 1/4W
R914	1-249-424-11	CARBON 3.9K	5% 1/4W
R915	1-249-428-11	CARBON 8.2K	5% 1/4W
R916	1-249-434-11	CARBON 27K	5% 1/4W
R917	1-249-431-11	CARBON 15K	5% 1/4W
R918	1-249-409-11	CARBON 220	5% 1/4W
R919	1-249-410-11	CARBON 270	5% 1/4W
R920	1-249-412-11	CARBON 390	5% 1/4W
R921	1-249-421-11	CARBON 2.2K	5% 1/4W
R922	1-249-421-11	CARBON 2.2K	5% 1/4W
R923	1-247-903-00	CARBON 1M	5% 1/4W

Ref. No.	Part No.	Description	Remarks
R925	1-249-425-11	CARBON 4.7K	5% 1/4W
R926	1-249-441-11	CARBON 100K	5% 1/4W
R927	1-249-441-11	CARBON 100K	5% 1/4W
R928	1-249-441-11	CARBON 100K	5% 1/4W
R929	1-249-433-11	CARBON 22K	5% 1/4W
R930	1-249-441-11	CARBON 100K	5% 1/4W
R931	1-249-425-11	CARBON 4.7K	5% 1/4W
< VARIABLE RESISTOR >			
RV541	1-241-330-11	RES, VAR, CARBON 20K/20K (PHONE LEVEL)	
RV591	1-238-833-21	RES, VAR, CARBON 20K/20K (REC LEVEL)	
RV592	1-238-687-11	RES, VAR, CARBON 50K/50K (BALANCE)	
RV593	1-241-329-11	RES, VAR, CARBON 5K/5K (REC LEVEL)	
RV594	1-241-328-11	RES, VAR, CARBON 10K/10K (BIAS)	
< SWITCH >			
S541	1-572-583-11	SWITCH, ROTARY (DOLBY NR)	
S542	1-572-764-11	SWITCH, PUSH (2 KEY) (CALIBRATION /MPX FILTER)	
S591	1-572-153-11	SWITCH, PUSH (1 KEY) (INPUT. CD DELECT /LINE)	
S592	1-572-582-11	SWITCH, ROTARY (REC EQ CAL)	
S701	1-572-267-51	SWITCH, PUSH (AC POWER) (1 KEY) (POWER)	
S801	1-572-268-11	SWITCH, SLIDE (TIMER)	
S901	1-554-303-21	SWITCH, TACTILE (COUNTER. MEMORY)	
S902	1-554-303-21	SWITCH, TACTILE (COUNTER. RESET)	
S903	1-554-303-21	SWITCH, TACTILE (DISPLAY MODE)	
S904	1-554-303-21	SWITCH, TACTILE (OPEN/CLOSE)	
S905	1-554-303-21	SWITCH, TACTILE (■)	
S906	1-554-303-21	SWITCH, TACTILE (◀◀)	
S907	1-554-303-21	SWITCH, TACTILE (▶▶)	
S908	1-554-303-21	SWITCH, TACTILE (REC)	
S909	1-554-303-21	SWITCH, TACTILE (▶)	
S910	1-554-303-21	SWITCH, TACTILE (PAUSE)	
S911	1-554-303-21	SWITCH, TACTILE (◀◀)	
S912	1-554-303-21	SWITCH, TACTILE (▶▶)	
S913	1-554-303-21	SWITCH, TACTILE (REC MUTE)	
S914	1-554-303-21	SWITCH, TACTILE (MONITOR)	
< VIBRATOR >			
X901	1-577-358-21	VIBRATOR, CERAMIC (4MHz)	

		MISCELLANEOUS	

156	8-719-980-85	DIODE SLF325C	
239	1-632-779-11	PC BOARD, FG	
5	* 1-590-321-51	LEAD (WITH CONNECTOR)	
CNP701	△1-575-651-11	CORD, POWER	
F801	△1-532-285-00	FUSE, TIME-LAG(1.25A)	
M1001	X-3356-638-1	MOTOR (REEL R) ASSY	
M1002	X-3356-604-1	MOTOR (ASSIST) ASSY	
S1001	1-466-238-11	ENCODER, ROTARY	
T701	△1-450-856-11	TRANSFORMER, POWER	

Note: The components identified by mark Δ or dotted line with mark Δ are critical for safety. Replace only with part number specified.

<u>Ref. No.</u>	<u>Part No.</u>	<u>Description</u>	<u>Remarks</u>	<u>Ref. No.</u>	<u>Part No.</u>	<u>Description</u>	<u>Remarks</u>
ACCESSORIES & PACKING MATERIALS				HARDWARE LIST			
*****				*****			
1-558-271-11		CORD, CONNECTION		#1	7-682-547-09	SCREW +BV 3X6, S TIGHT	
* 3-363-900-01		CUSHION		#2	7-685-133-19	SCREW +BTP 2.6X6 TYPE2 N-S	
* 3-376-746-01		INDIVIDUAL CARTON		#3	7-682-547-04	SCREW +BVTT 3X6 (S)	
3-755-112-11		MANUAL, INSTRUCTION		#5	7-682-548-04	SCREW +BVTT 3X8 (S)	
		(ENGLISH/FRENCH/SPANISH/PORTUGUESE) (AEP)		#6	7-682-548-09	SCREW +BVTT 3X8 (S)	
3-755-112-41		MANUAL, INSTRUCTION		#7	7-682-147-15	SCREW, TR	
		(GERMAN/DUTCH/SWEDISH/ITALIAN) (AEP)		#8	7-682-548-09	SCREW +B 3X8	
3-755-112-51		MANUAL, INSTRUCTION (GERMAN) (G)		#9	7-682-547-04	SCREW +BVTT 3X6 (S)	
				#10	7-621-849-00	SCREW (BV/RING)	
				#11	7-628-253-00	SCREW +PS 2X4	
				#12	7-628-254-10	SCREW +PS 2.6X6	
				#13	7-671-154-01	STENLESS BALL	
				#14	7-682-648-09	SCREW +PS 3X8	
				#16	7-621-255-20	SCREW +BVTT 2X4 (S)	
				#17	7-621-255-35	SCREW +BVTT 2X5 (S)	
				#18	7-685-870-01	SCREW +BVTT 3X5 (S)	
				#20	7-621-772-70	SCREW +B 2X14	
				#21	7-622-205-05	NUT M2 TYPE2	
				#22	7-621-775-10	SCREW +B 2.6X4	
				#23	7-685-533-19	SCREW +BV 2.6X8 TAPPING	