

SUGGESTED PRICE
50 CENTS

RCA

RCA



operating and
maintenance
instructions

**VoltOhmyst®
WV-77E**

RCA | Electronic Instruments | Harrison, N.J. 07029

Safety Precautions

The metal case of this instrument is connected to the ground of the internal circuit through a resistance-capacitance network. For proper operation, the ground cable of the WV-77E should always be connected to the ground of the equipment under test, before any other connections are made. Always handle the probes by the molded plastic probe housing.

An important point to remember is that there is always danger inherent in testing electrical equipment which operates at hazardous voltages. Therefore, the operator should thoroughly familiarize himself with the equipment under test before working on it, bearing in mind that high voltages may appear at unexpected points in defective equipment. Additional precautions which experience in the industry has shown to be important are listed below.

1. It is good practice to remove power before connecting test leads to high-voltage points. If this is impractical, be especially careful to avoid accidental contact with equipment racks and other objects which can provide a ground. Working with one hand in your pocket and standing on a properly insulated floor lessens the danger of shock.
2. Filter capacitors may store a charge large enough to be hazardous. Therefore, discharge filter capacitors before attaching test leads.
3. Remember that leads with broken insulation provide the additional hazard of high voltages appearing at exposed points along the leads. Check test leads for frayed or broken insulation before working with them.
4. To lessen the danger of accidental shock, disconnect test leads immediately after test is completed.
5. Remember that the risk of severe shock is only one of the possible hazards. Even a minor shock can place the operator in hazard of more serious risks such as a bad fall or contact with a source of higher voltage.
6. The experienced operator continuously guards against injury and does not work on hazardous circuits unless another person is available to assist in case of accident.

Items supplied with the WV-77E

1 DC Probe and Cable	1 Ground Cable
1 AC-Ohms Probe and Cable	1 Instruction Booklet

General Description

The VoltOhmyst®* WV-77E is designed to measure ac rms values of sine-wave voltages from 0.1 to 1500 volts, dc voltages from 0.02 volt to 1500 volts, peak-to-peak voltages from 0.2 volt to 4000 volts, and resistance values from 0.2 ohm to 1000 megohms. The ac voltmeter portion of the WV-77E features an electron tube as the full-wave signal rectifier. The meter reading in ac-voltage measurements is a function of the full peak-to-peak value of the measured waveform. The WV-77E has a high input impedance on all dc- and ac-voltage ranges. The high impedance input allows the use of the WV-77E in circuits where instruments with a lower input impedance would result in loading of the circuit under test, and a resultant error in reading the operating voltage.

The VoltOhmyst utilizes a push-pull balanced dc-bridge circuit with the meter in the plate circuit. This circuit affords excellent linearity of response, good stability, and very high input impedance. (See Schematic Diagram, Page 14.)

Additional features of the WV-77E include provision for zero-center indication, useful in discriminator and bias measurements; separate scales for low ac-voltage measurements to assure accurate readings; a circuit design which allows measurement of ac in the presence of dc and vice versa; a separate dc probe with a 1-megohm resistor which minimizes capacitance-loading effects; and electronic protection against meter burn-out. In addition, the resistors in the resistance divider network are protected by a separate fuse.

The WV-77E VoltOhmyst is a light-weight, compact, versatile instrument. This reliable measuring device will prove extremely useful in television applications as well as in many industrial applications.

Specifications

Electrical

Performance figures are for line voltage of 120 volts, 60 cps.

DC Voltmeter

Ranges	0 to 1.5, 5, 15, 50, 150, 500, 1500 volts
Input Resistance with DC probe (1 megohm inside probe)	
All Ranges	11 megohms
Accuracy	±3% of full scale

* TMK® Marca (s) Registrada (s)

AC Voltmeter**Ranges:**

RMS Values of Sine Waves (0 to 1.5 volts on separate scale
) 0 to 5, 15, 50, 150, 500, 1500 volts

Peak-to-Peak Values of
 Sine Waves (0 to 4 volts on separate scale
) 0 to 14, 40, 140, 400, 1400, 4000 volts

Accuracy $\pm 5\%$ of full scale

Frequency Response

$\pm 5\%$ 40 cps to 5 Mc. On 1.5, 5, 15 rms, or 4, 14, 40, p-p ranges

Maximum Input Voltages

When instrument is set up to measure DC:

DC 1500 volts
 DC plus AC (peak) 1800 volts

When instrument is set up to measure AC:

Maximum AC (rms) 1500 volts
 Maximum AC (peak-to-peak) 4000 volts

NOTE: When AC is being measured, no more than 400 volts DC shall be present in circuit being tested.

Tube Complement 1 RCA-6AL5, 1 RCA-12AU7-A

Power Supply:

Voltage Rating 105 to 125 volts
 Frequency Rating 50 to 60 cps

Battery:

1.5-volt cell RCA-VSO35

Mechanical**Dimensions: (less handle)**

Height $7\frac{3}{4}$ inches
 Width $5\frac{5}{8}$ inches
 Depth $4\frac{3}{4}$ inches
 Weight 5 pounds

Functions of Controls and Terminals

FUNCTION SELECTOR — Has two functions; turns the power off in "OFF" position, and permits choice of type of measurement to be made.

RANGE SELECTOR — Permits choice of range for the desired voltage or resistance measurement.

ZERO ADJ control — Used to position the meter pointer to the left-hand "0" and to zero-center the pointer when the function selector is set to either "+VOLTS" or "-VOLTS".

OHMS ADJ control — Used to position the meter pointer at the extreme right line on the "OHMS" scale when the function selector is in "OHMS" position.

AC OHMS jack — blue lead plugs into this connector and is used to measure ac voltage and resistance as described under "Operation" below.

DC jack — red lead plugs into this connector, and is used to measure dc voltage as described under "Operation" below.

GROUND jack — black lead plugs into this connector, and is connected to the ground of the circuit under test for all voltage measurements. This lead is also used for making resistance measurements as described under "Operation" below.

Operation and Applications**Preliminary Adjustments:**

To prepare the WV-77E for use, make the following connections and adjustments:

1. Connect the cables to the appropriate front-panel connectors.
2. Plug the power cord into an ac outlet supplying 105-125 volts at 50-60 cps and adjust the controls as follows:
 - a. Set the function selector to "+DC VOLTS" and allow a few minutes for the instrument to warm up.
 - b. Adjust the ZERO control to position the meter pointer at the left-hand zero on the scales.
 - c. Turn the function selector to "R OHMS." The pointer should deflect to approximately full scale.
 - d. Rotate the OHMS ADJ control to position the pointer at the last line on the "Ohms" scale.

Continued on Page 7

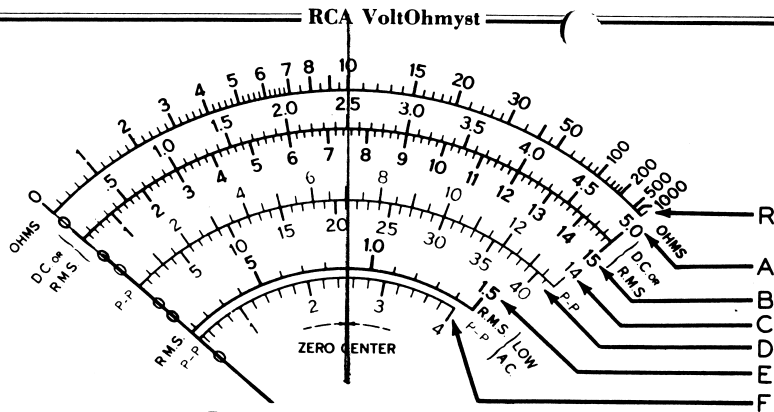

Figure 1. WV-77E Meter Scales

TABLE 1
RESISTANCE MEASUREMENTS

Resistance to be measured	Set Range Switch to:	Read from Scale	Multiply Reading by
0.2 to 1000Ω	R X 1	R	1
1000 to 10000Ω	R X 10	R	10
10000 to 100000Ω	R X 100	R	100
100000Ω to 1 MEG	R X 1000	R	1000
1 MEG to 10 MEG	R X 10K	R	10000
10 MEG to 100 MEG	R X 100K	R	100000
100 MEG to 1000 MEG	R X 1 MEG	R	1 MEG

DC-VOLTAGE MEASUREMENTS

Voltage to be measured	Set Range Switch to:	Read from Scale	Multiply Reading by
0.02 to 1.5V	1.5V	B	0.1
1.5V to 5V	5V	A	1
5 to 15V	15V	B	1
15 to 50V	50V	A	10
50 to 150V	150V	B	10
150 to 500V	500V	A	100
500 to 1500V	1500V	B	100

AC RMS VOLTAGE MEASUREMENTS

RMS voltage to be measured	Set Range Switch to:	Read from Scale	Multiply Reading by
0.1 to 1.5V	1.5V	E	1
1.5V to 5V	5V	A	1
5 to 15V	15V	B	1
15 to 50V	50V	A	10
50 to 150V	150V	B	10
150 to 500V	500V	A	100
500 to 1500V	1500V	B	100

AC PEAK-TO-PEAK VOLTAGE MEASUREMENTS

Peak-to-peak voltage to be measured	Set Range Switch to:	Read from Scale	Multiply Reading by
0.2 to 4V	4V	F	1
4 to 14V	14V	C	1
14 to 40V	40V	D	1
40 to 140V	140V	C	10
140 to 400V	400V	D	10
400 to 1400V	1400V	C	10
1400 to 4200V	4000V	D	100

(Continued from Page 5)

e. Turn the function selector to the "AC" position, and set the range switch to the "1.5V" position. The pointer should deflect back to the left-hand zero. The instrument is now ready for use.

Use of Range and Meter Scales:

The meter scales on the WV-77E have been designed to provide ease of operation and quick readability over a wide range of measurements. Scales have been grouped according to the type of measurement for which they are used. The "Ohms" scale, at the top of the scale plate, is used only for resistance measurements, and all resistance measurements are read from this one scale. All dc voltages are read from the two scales marked "A" and "B" in Figure 1. The rms values of sine-wave voltages are also read from scales marked A and B. The corresponding peak-to-

peak values are read from scales marked C and D. Scale E is used for ac measurements up to 1.5 volts. The corresponding peak-to-peak values are read from scale F. The particular scale which is used for any given function is determined by the setting of the range switch.

Table I has been prepared as an aid in selection of ranges, scales, and multiplying factors for all measurements which can be made with the WV-77E.

Because of the wide number of measurement ranges provided on the WV-77E, it is often possible to take voltage or resistance reading on two ranges and scales. For greatest accuracy in voltage measurements, always use the range which will provide an on-scale reading which is nearest to the full-scale point. For example, 48 dc volts can be read from either the 50-volt or the 150-volt range. Because the 50-volt range will provide a reading nearest the full-scale point, the 50-volt range only should be used if a reading of best accuracy is to be obtained. This general rule applies to all ac- and dc-voltage ranges. For ohms measurements, however, the range-selected should be the one which provides a reading nearest the center of the scale because the VoltOhmyst provides the most accurate readings at mid-scale points.

For some measurements it will be necessary to use a multiplying factor with the scale reading to obtain the correct reading. The required multiplier is indicated by the setting of the range switch. For example, when the range switch is set to the 500-volt position for a dc-voltage measurement, the "A" scale (Figure 1) is used. Because this scale has a full scale value of "5", it is necessary to multiply any readings on this scale by 100 to obtain the correct value.

Normal Operating Characteristics:

With a high-impedance, high-sensitivity meter, such as the Volt-Ohmyst, it is entirely normal to expect a deflection of the meter pointer when the leads are touched and the meter "Range" switch is in one of the lower voltage positions.

In the AC position, touching the AC probe will cause the meter to deflect, which indicates that your body is in a strong AC field. If you touch the ground lead at the same time, the reading will decrease almost to zero, depending on the resistance of your hand connection, body resistance, and relative strength of the AC field.

In the DC position, touching the DC probe will cause the meter to "kick", but the pointer will return to zero. However, if you hold the DC probe in one hand and hold the ground lead in the other hand, the meter may remain deflected, simply because it is reading the contact or "battery" potential created by your hands in contact with the probe connections which are made of dissimilar metal. Try holding a nickel (5-cent coin) in each hand, and then touch the probe and ground lead with the coins—now the pointer deflects very little.

The above effects are a natural phenomena and do not appear during normal application of the instrument because the source impedance of circuits being measured are only a fraction of the instrument impedance. Consequently, the phenomena has no bearing on the accuracy or useability of the instrument.

Resistance Measurements:

When making resistance measurements, the AC-OHMS Probe should be used.

CAUTION: Before resistance measurements are made, the power should be removed from the equipment under test so that no voltages are present in the equipment.

1. Set the function selector to "OHMS" position.
2. Set the range selector to the position nearest to the value under measurement.
3. Connect the probe tip to the ground clip and adjust the ZERO ADJ control to position the pointer at the left-hand "0", if necessary.
4. Disconnect the probe from the Ground Clip. Meter pointer will deflect approximately full scale. If meter pointer does not deflect to exactly full scale, use OHMS ADJ control to adjust setting accurately to the last line on the "Ohms" scale. (See Ohms Adjustment section on page 18 if it is necessary to frequently readjust the OHMS ADJ control.)
5. Connect the clip of the Ground Cable to one terminal of the resistance to be measured.
6. Touch or connect the probe tip to the other terminal of the resistance to be measured.
7. Reset the range switch to give a convenient deflection on the "Ohms" scale. nearest midscale
8. Multiply the reading on the "Ohms" scale by the factor indicated at the range-selector setting. See Table 1.

NOTE: If erratic operation is experienced, it is probably due to a blown fuse, F1, Stock #99328.

CAUTION: Low-current, low-resistance devices, such as thermocouples and meter movements, may be damaged unless a range above "R x 1" is used because the WV-77E applies up to 1.5 volts across the resistance under measurement when the range selector is set at "R x 1".

In the case of resistance measurements, the OHMS Probe of the WV-77E is always positive with respect to the Ground Cable. This facilitates the measurement of leakage resistance in components such as electrolytic capacitors where polarity must be observed.

DC-Voltage Measurements:

CAUTION: See Maximum Input Voltages, under ELECTRICAL SPECIFICATIONS.

When making dc-voltage measurements, the DC Probe should be used.

The WV-77E has seven dc-voltage ranges from 0 to 1.5, 5, 15, 50, 150, 500, and 1500 volts. Although the meter is protected against burn-out, it is good practice to make a trial measurement at a higher range setting than is considered necessary, because long-continued or repeated overload of the meter movement may eventually impair the accuracy of indication.

To measure dc voltages, proceed as outlined below:

1. Set the function selector to "+VOLTS" or "-VOLTS" as required.
2. Connect the Ground Cable clip to ground.
3. Set the range selector to a position considerably higher than the voltage to be measured.
4. Touch or connect the DC Probe to the high side of the source voltage.
5. Reset the range selector to a position which gives a suitable pointer deflection. *nearest full scale*
6. Read the dc voltage from the scale corresponding to the range-selector setting. See Table 1.

Zero-Center Indication:

Zero-center indication is frequently useful because it allows observation of either positive or negative dc-voltage excursions without the necessity of resetting the function selector.

1. Set the function selector to "+VOLTS".
2. Rotate the ZERO ADJ control to position the pointer at the center " " zero center. If the ZERO ADJ control does not have sufficient range to move the pointer to the zero center position, switch the function selector to "-VOLTS".
3. Make a test reading and then reset the range selector to the lowest position which allows the pointer to remain on the scale.

AC-Voltage Measurements:

CAUTION: See Maximum Input Voltages, under "Specifications". The AC probe should be used for all ac-voltage measurements.

1. Set the function selector to the "AC VOLTS" position.
2. Set the range selector to a position higher than the voltage to be measured.
3. Adjust the ZERO ADJ control if necessary to position the meter pointer at the left-hand "0". Ground the ac probe when making this adjustment on the 1.5 and 5.0 volt ranges.
4. Connect the ground clip to the ground of the circuit under test.
5. Touch or connect the ac probe to the high side of the source voltage.
6. Read the ac voltage from the scale corresponding to the range-selector setting. See Table 1. *nearest full scale*

ACCESSORIES

(Available on Separate Order)

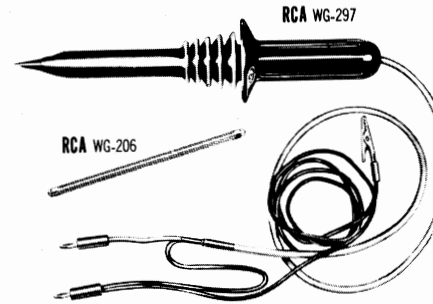

Figure 2A.

WG-297 High Voltage Probe

The WG-297 High Voltage Probe, in combination with the WG-206 Multiplier Resistor, extends the dc rating of the WV-77E and WV-77E(K) VoltOhmysts to a maximum of 50,000 volts. The probe multiplies the dc scales by a factor of 100, and increases the input resistance to 1100 megohms.

Figure 2B.
WG-351A RF Probe

The WG-351A RF Probe consists of a semi-conductor rectifier and an RC network, complete with housing, cable, and banana plugs. The WG-351A reads the rms values of sine waves on the dc scales of the WV-77E and WV-77E(K) VoltOhmysts. The frequency range of the WG-351A is 50 kc to 250 mc, and the maximum voltage rating is 20 rms volts in the presence of 250 dc volts.



Maintenance

The WV-77E may be removed from the case by removing four screws from the front panel. The rubber grommet in the case may also be removed to permit the ac-line plug to pass through the hole in the case.

The performance of the VoltOhmyst is dependent upon the quality and tolerances of its components. Only RCA parts should be used for replacements.

Zero Setting of Pointer

Mechanical Adjustment:

The pointer should rest at "0" when the function switch is in the "OFF" position. If the pointer should come to rest at a deflected position, adjust the plastic screw on the front of the meter case so that the pointer lines up with the "0" point on the meter.

If the difficulty remains, vigorously wipe the outside surface of the meter-case window with a clean, soft, dry cloth. If the pointer moves away from its initial position and remains at another off-zero position for several minutes, the anti-static coating on the inside surface of the window is no longer effective. To restore the anti-static coating, apply a small amount of liquid detergent (such as those used for washing dishes) to a soft cloth and gently wipe the front of the meter case. If this procedure is not effective, remove the front of the meter case by carefully prying the top of the case away from the body of the instrument with a thin-bladed screwdriver. Pour a small quantity of the detergent into the plastic case front so that the entire inside surface is covered. Pour the excess liquid out, and allow the case front to dry. Replace the meter front.

DC Zero Check:

1. Set function selector to "-VOLTS", and remove the red lead from the dc jack.
2. Set range selector to "1.5V".
3. Rotate the ZERO ADJ control until the meter pointer is at zero.
4. Turn range selector to "1500V".
5. If the meter pointer deviates from zero by more than one division on the 0 to 15 meter scale, replace the 12AU7-A (see section on Tube Replacement).

AC Zero Check:

1. Set the function selector to "AC" and remove the blue lead from the ac jack.
2. Set the range selector to "1.5V".
3. Rotate the function selector from AC through -DC and +DC.
4. If the meter pointer deflects from "0", adjust the AC BAL control (R-18, upper section of 3-section potentiometer) so that there is no movement of the pointer as the function selector is rotated.

Calibration

Two methods can be used for the dc voltage calibration of the WV-77E. The first utilizes a readily available source of dc voltage — a fresh

flashlight cell, the other utilizes a variable, metered power supply. Remember that the accuracy of the instrument is dependent on the accuracy of the calibration voltage.

DC-Voltage Calibration

Method 1

1. Set the Range selector to "1.5V" and the Function selector to "+DC" volts.
2. Set the meter pointer to zero by using the ZERO ADJ control.

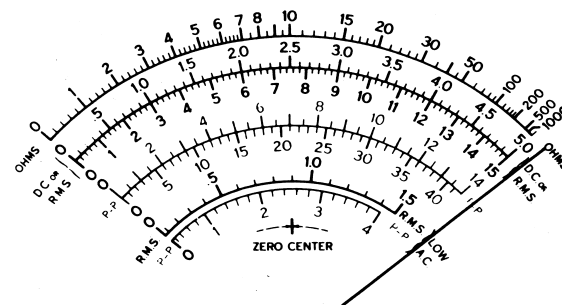

Figure 3. Position of the Meter Pointer for dc-Voltage Calibration (Method 1)

3. Connect the GROUND Cable to the negative side and the DC probe to the positive side of a fresh flashlight battery, such as the RCA-VSO35.
4. Adjust the "DC CAL" control (R-7, center section of 3-section potentiometer) inside the case so that the meter pointer is positioned just to the right of the bracket on the 5/15 meter scale (See Fig. 3). This point has a value of 1.55 volts.
Note: A calibrated cell is not required since a fresh flashlight battery will measure 1.55 volts.
5. Disconnect the leads from the battery. The instrument should now be ready for use on any dc range.

Method 2

1. Set the Range selector to "50V" and the Function selector to "+VOLTS".

Continued on Page 17

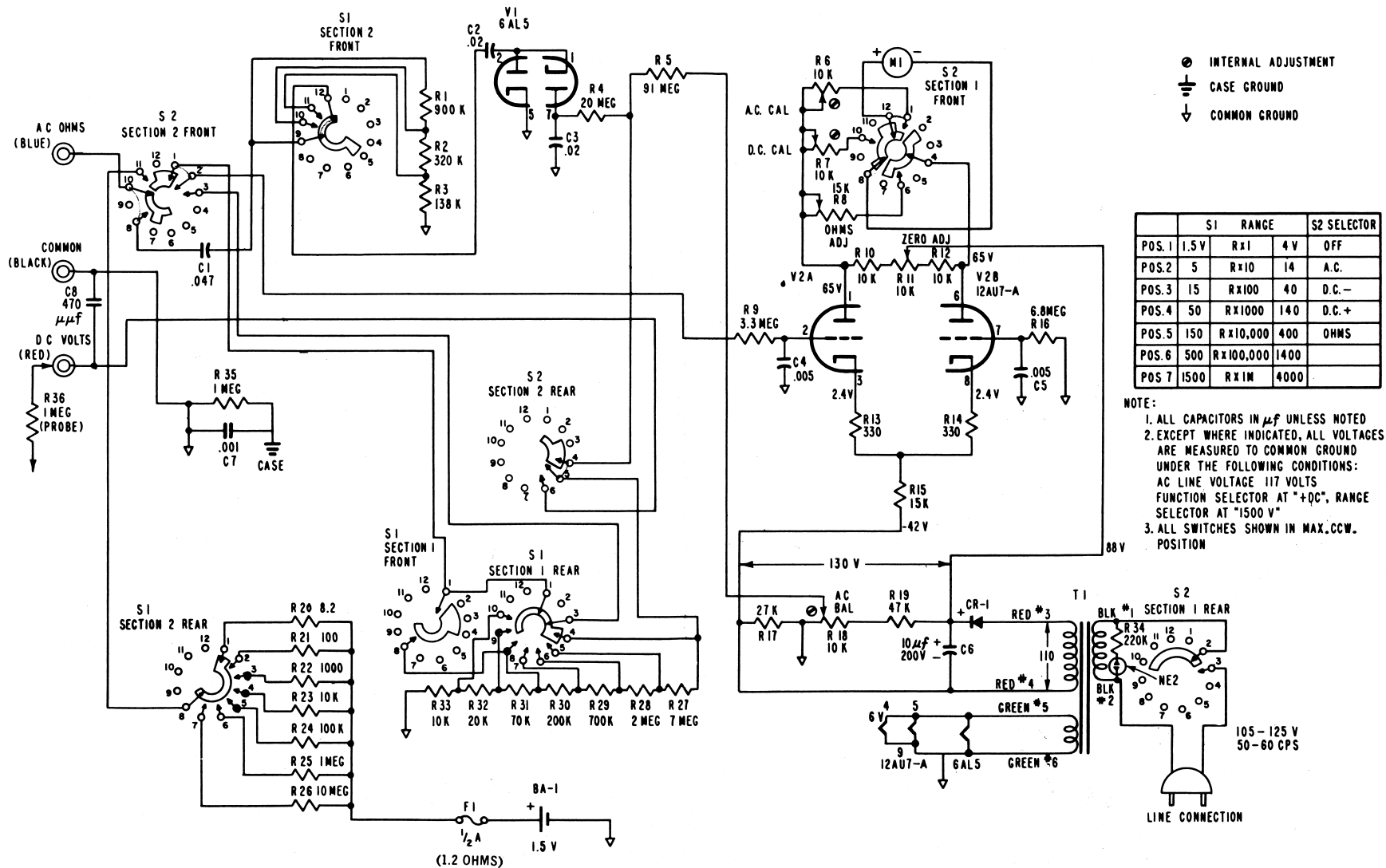

Schematic Diagram of the WV-77E

Replacement Parts List WV-77E VoltOhmyst

When ordering replacement parts, include the stock number and description of the part, the instrument type, and the code number. Parts without stock numbers are standard catalog items. All parts should be ordered from your local RCA distributor.

Symbol No.	Description	Stock No.	Symbol No.	Description	Stock No.
Capacitors					
C1	Tubular, 0.047 μ f \pm 20%, 400 volts	300590	R21	100 ohm \pm 5%, 1/2 watt	502110
C2, C3	Ceramic disc, 0.02 μ f \pm 20%, 400 volts	210685	R22	1000 ohm \pm 5%, 1/2 watt	502210
C4, C5	Ceramic disc, 0.005 μ f GMV, 200 volts	98068	R23	10,000 ohm \pm 5%, 1/2 watt	502310
C6	Electrolytic, 10 μ f -10%, +100%, 200 volts	218002	R24	100,000 ohm \pm 5%, 1/2 watt	502410
C7	Ceramic disc, 0.001 μ f GMV, 500 volts	77252	R25	1 meg, \pm 5%, 1/2 watt	502510
C8	Ceramic disc, 470 μ f, 1600 volts	103902	R26	10 meg, \pm 5%, 1/2 watt	502610
CR1	Rectifier: Silicon	235382	R27	Carbon film: 7 meg, \pm 1%, 1/2 watt	59538
F1	Fuse: 1/2 amp, pigtail, 3 AG (Littelfuse or Buss GJV) *	99328	R28	Carbon film: 2 meg, \pm 1%, 1/2 watt	224722
NE2	Lamp: Neon, 5" leads	218017	R29	Carbon film: 700,000 ohm \pm 1%, 1/2 watt	59541
M1	Meter, 400 μ A	217925	R30	Carbon film: 200,000 ohm, \pm 1%, 1/2 watt	224203
Resistors					
R1	Carbon film: 900,000 ohm \pm 1%, 1 watt	59536	R31	Carbon film: 70,000 ohm, \pm 1%, 1/2 watt	59542
R2	Carbon film: 320,000 ohm \pm 1%, 1/2 watt	59544	R32	Carbon film: 20,000 ohm, \pm 1%, 1/2 watt	218657
R3	Carbon film: 138,000 ohm \pm 1%, 1/2 watt	218021	R33	Carbon film: 10,000 ohm, \pm 1%, 1/2 watt	218277
R4	20 meg \pm 5%, 1/2 watt	502620	R34	220,000 ohm, \pm 20%, 1/2 w	502422
R5	91 meg \pm 20%, 1/2 watt	218020	R35	1 meg, \pm 5%, 1/2 watt	502510
R6, R7	Variable: 3 sect., 10,000 ohm, \pm 35%, 1/2 watt, plug-in type. Includes R6, R7, R18	217922	R36	1 meg, \pm 5%, 1/2 watt	502510
R8	Variable: 15,000 ohm, \pm 20%, 1/2 watt	218019	Switches		
R9	8.3 meg. \pm 10%, 1/2 watt	502533	S1	Switch: Rotary "Range"	217924
R10	10,000 ohm \pm 5%, 1/2 watt	502310	S2	Switch: Rotary "Selector"	217923
R11	Variable: 10,000 ohm \pm 20%, 1/2 watt	218018	Miscellaneous		
R12	10,000 ohm \pm 5%, 1/2 watt	502310	Board: laminated circuit	217929	
R13, R14	330 ohm \pm 5%, 1/2 watt	502133	Case: meter, front, clear plastic	217926	
R15	15,000 ohm \pm 5%, 1/2 watt	502315	Case: meter, rear, clear plastic	217927	
R16	6.8 meg. \pm 10%, 1/2 watt	502568	Clamp: battery	220317	
R17	27,000 ohm \pm 5%, 1/2 watt	502327	Connector, black, banana jack	230889	
R18	Part of R6		Connector, blue, banana jack	230890	
R19	47,000 ohm \pm 5%, 1/2 watt	502347	Connector, red, banana jack	230888	
R20	Wire wound: 8.2 ohm \pm 5%, 5 watt	220997	Connector: alligator clip Mueller #60/Philmore #1956A*	70892	
			Cord: power cord and plug		
			Foot: case, rubber, Atlantic India Rubber Co. #716* ground cable	220246	
			Handle	226241	

Unless otherwise stated all resistors shown are composition type.

Symbol No.	Description	Stock No.	Symbol No.	Description	Stock No.
	Knob: control, black	72129		Test Probes and Cables, complete Socket: 7-pin miniature Ind. Hardware #MP-14* Socket: Noval Ind. Hardware #NP-16* Transformer: Power	WG-277A 217921
	Knob: control, black rubber	94878			
	Probe: test, red, H. H. Smith, Inc. #319*	220244			
	Probe: test, blue, H. H. Smith, Inc. #319*	220245			

* Replace only with same type. This fuse is part of the Ohms-divider network.

* Or equivalent.

(Continued from Page 13)

2. Set the meter pointer to zero by adjusting the ZERO ADJ control.
3. Connect the Ground Cable to the negative terminal and the probe tip to the positive terminal of a source of DC Voltage that has been adjusted to exactly 47 volts.
Note: The accuracy of calibration cannot exceed the accuracy of the voltage standards which are used.
4. Adjust the "DC CAL" control (R-7) inside the case for a meter reading of exactly 47 volts.
5. Remove the leads at the source of voltage.
6. Set the function selector to "-VOLTS".
7. Connect the Ground Cable to the positive terminal and the probe tip to the negative terminal of the dc-voltage source adjusted to exactly 47 volts. The WV-77E should read 47 volts within \pm 3%.
8. If the WV-77E cannot be calibrated according to the foregoing steps, the 12AU7-A bridge tube may not be properly balanced for this application.

AC-Voltage Calibration

1. Set the Range selector to "150V" and the Function selector to "AC".
2. Connect the AC-OHMS probe and the GROUND probe to a 117 volt ac line or to a variable, metered ac-voltage source. NOTE: See Safety Precautions on page 2.
3. Adjust the AC CAL control (R-6, lower section of 3-section potentiometer) inside the case for a meter reading of exactly 117 volts.

Tube Replacement

All tubes supplied originally with the WV-77E have been thoroughly aged by operating them for several hours before installation in the instrument. This preliminary conditioning of a new tube helps to insure stability and dependable performance.

Before installing a 12AU7-A, age the tube as follows: Connect the two plates together. Connect both grids and cathodes together. Operate the tube with 115 volts dc applied to the plates, no voltage applied to the grids and cathodes, and 6.3 volts ac applied to the heaters. The tube should be operated in this manner for a minimum of 12 hours before it is installed in the instrument. The WV-77E then can be recalibrated.

An alternate, and usually satisfactory, aging procedure consists of operating the new tube in the WV-77E for approximately 36 to 48 hours, after which time the instrument may be recalibrated. If this procedure is unsatisfactory, the first aging procedure should be followed.

If it becomes necessary to replace the 6AL5, the tube can be aged for a minimum period of 36 hours by operating it in the WV-77E. After this period of time, the instrument may be recalibrated according to the procedure outlined under "AC Calibration Check".

Battery Testing and Replacement

Caution: Do not allow exhausted cells to remain inside the case of the WV-77E. Chemicals from deteriorated cells may damage the instrument.

The battery should be tested to insure accuracy of resistance measurements. To test battery, proceed as follows:

1. Set Function selector to "OHMS".
2. Set Range selector to "R x 1" scale.
3. Rotate OHMS ADJ control to bring pointer to full scale.
4. Short-circuit the probe tip and ground clip for about ten seconds.
5. Open the short-circuit and immediately observe the scale indication. An appreciable deviation from full-scale indication reveals a weak cell which should be replaced.

Ohms Adjustment

In order to obtain exactly full-scale deflection of the meter when switching the range selector from a low range position to the R x 1 MEG position, it may be necessary to readjust the OHMS ADJ control. The

necessity for this readjustment can be minimized by checking the battery and installing a 12AU7-A tube. Refer to Tube Replacement section.

RCA Repair Service

RCA maintains repair depots for the adjustment, calibration and maintenance of RCA test equipment. For the name of the repair depot nearest you, contact your local RCA distributor, or write to RCA Test Equipment, 19th and Federal Sts., Camden, N.J. If it becomes necessary to service this equipment, the report form enclosed with this booklet should be filled out as described and returned with the instrument.

Trouble-Shooting the WV-77E

Circuit Description

The operation of the WV-77E centers around a vacuum-tube bridge circuit. The bridge circuit is composed of the two triode units of an RCA-12AU7-A. When the two sections of the bridge are balanced, there is no voltage difference between the two plates, therefore, the meter which is connected between the plates reads zero. The ZERO ADJ control is used to adjust the plate load resistor so that the two sections of the 12AU7-A are balanced.

When a positive voltage is applied to the grid of V2A, the current flowing through this unit of the tube increases, causing the plate voltage of V2A to decrease. This current also flows through resistor R-15, which is common to both V2A and V2B, increasing the voltage drop across the resistor and biasing V2B in a negative direction. This bias voltage decreases the plate current, causing the plate voltage of V2B to increase. As a result, the current flows through the meter from V2B to V2A. Since this current is directly proportional to the applied voltage, the calibrated meter indicates the applied voltage.

When the WV-77E is used to measure ac voltage, the voltage is first rectified by an RCA-6AL5 twin diode ac-signal rectifier. The circuit is designed so that the voltage developed by one-half of the ac cycle is added to the voltage developed by the other half of the ac cycle. The dc voltage thus developed is the peak-to-peak value of the applied ac

voltage. This dc voltage is then applied to the grid of V2A through a voltage divider and the bridge-circuit operates as described above.

With the ac-signal rectifier, 6AL5, in the circuit, a difference in the materials used in the plate and cathode may cause a small voltage to appear at the input to the bridge circuit. This voltage, called contact potential, would cause a slight meter deflection. In the WV-77E, a small voltage (bucking voltage) of opposite polarity is fed back to cancel the contact potential. The required value of this bucking voltage is adjusted by means of the AC BAL control, R-18.

A flashlight battery inside the instrument is used to provide a dc voltage for resistance measurements. This voltage is applied through the ohms divider-network to the grid of V2A. The voltage applied to the grid causes the meter pointer to deflect to full scale. When a resistor is connected between the ohms probe and the ground probe, the resistor is in series with the ohms divider-network. The battery voltage is divided between the internal network and the external unknown resistance. Therefore, a smaller voltage appears at the grid of V2A causing a right-to-left deflection of the meter pointer. The WV-77E incorporates a fuse in the ohms circuit to prevent damage to the resistors in the divider network.

Maintenance

The WV-77E is a relatively simple instrument. Troubles which develop may usually be analyzed without difficulty. Check the instrument on all ranges and on all functions before attempting any repairs. Examination of the schematic diagram will show that the voltage divider network used for resistance measurements is not used when making voltage measurements. Other differences will also be evident. For example, V1 the ac-signal rectifier and its associated circuits are used only when the WV-77E is set to "AC". A complete performance check will be of great help in isolating the trouble.

When trouble is encountered, a visual check of wiring should be made first. All wiring and solder joints should be inspected closely. Shorted leads or burned components may indicate quickly where the trouble is. The causes and possible remedies listed are given in probable order of occurrence. The description of the trouble should be located in the bold-face type and possible causes checked in the order listed.

When soldering to or near the switches, care should be taken to prevent overheating or mechanically scraping the precision resistors in the

divider networks. Excessive heating may permanently change the value of the resistors and result in inaccurate meter readings. A pair of long-nose pliers may be clamped to the lead between the resistor being soldered and the point of connection to dissipate as much heat as possible. Care should also be taken to prevent twisting or loosening of the switch contacts and to prevent solder from getting down into the switch. Contacts may be cleaned with cigarette-lighter fluid.

General

Meter pointer moves off zero ("0") when Range Switch is moved from one range to another, or when Function Switch is shifted from "-DC VOLTS" to "+DC VOLTS".

1. This type of trouble is usually caused by condensed surface moisture which is accumulated during periods of non-usage in humid weather. The trouble will correct itself after the instrument is turned "ON" for a few hours—the heat from the tubes and the transformer will evaporate the moisture.

Instrument fails to operate on all functions; tubes do not light.

1. Line cord broken or not making contact at outlet.
2. Switch S2 Sect. 1, rear, defective.
3. T1 defective. Check continuity of windings and resistance to ground.

Instrument fails to operate on all functions; tubes light, ZERO ADJ does not work.

1. Broken lead in ground cable or common jack defective.
2. Incorrect operating voltages on 12AU7-A bridge tube. Measure tube and power supply voltages with voltmeter.
3. V2 defective. Replace as described under section "Tube Replacement."
4. Open or short circuit in V2 bridge circuit. Check out with ohmmeter. Check each component, especially R10, R11, R12, C6, T1 secondary, and meter leads.
5. Check switch S2.
6. CR-1 defective.

Meter pointer sticks.

1. Cracked or broken jewel bearing in meter. NOTE: Individual replacement parts for meter movement are not available. Meter should be returned for repairs or replaced with new meter.
2. Scale plate on meter is loose and is striking pointer. Remove meter from meter case and tighten mounting screws.

Meter pointer moves sluggishly; slow return to zero point.

1. Anti-static solution on inside of plastic meter window is no longer effective. Recoat with solution. See section on "Zero Setting of Pointer".

Meter pointer bangs hard left or right, depending upon setting of function switch.

1. Open or short circuit in bridge circuit.

Intermittent operation on all functions.

1. Loose or broken connections in cables. Check by flexing cables and observing meter readings.
2. Poor ground connection between ground jack and ground bus of chassis. Check lead to R35.
3. Wiper contacts on S2 defective.
4. Loose or broken connection in bridge circuit wiring or components, including meter terminals. With power applied, probe wiring, connections, and components with insulated probe. CAUTION: See "Safety Precautions", page 2.
5. Loose or defective component in power supply.
6. V2 defective. Replace tube as described under "Tube Replacement".

ZERO ADJ control erratic in operation.

1. Potentiometer R11 defective. Replace with new control. NOTE: First, make sure mechanical zero of meter pointer is correct. See "Zero Setting of Pointer".

Ohms Function

Instrument fails to indicate on OHMS; works normally on ac and dc voltage measurements.

1. Battery exhausted or not making contact.
2. Fuse F1 open. To replace fuse, clip leads at point of contact with end cups. Hold with pliers, and solder new fuse to stub ends of leads.
3. Loose or broken connection in ohms cable. Check by flexing cable and observing meter reading.
4. Defective wiper contact on switch S1, Sect. 2, rear.
5. "Ohms" contact (terminal 11) on S2, Sect. 2, front defective.
6. OHMS jack, or lead open or shorted to other wiring or to instrument. Check resistance to case and adjacent wiring.
7. Cable connector not making contact.

OHMS ADJ fails to give infinity setting on "R" scale.

1. Battery exhausted.
2. OHMS ADJ potentiometer, R8, defective.
3. S2 defective.

Resistance readings inaccurate on some or all "ohms" ranges.

1. One or more resistors in network around switch S1, Sect. 2, rear, have changed value. Fuse, F1, has developed a high resistance.
2. Excessive leakage in "ohms" circuit. Check switch wafers on S1 for dirt or damage. NOTE: High humidity after a prolonged idle period may cause leakage and inaccurate readings on high ohms scales. Operate instrument for several hours until thoroughly warm and dry.
3. Poor contact from ground jack to ground bus on chassis.
4. Shorted wiring in resistor network around S1.
5. Faulty or high-resistance connections in "ohms" circuit.

Meter pointer moves off infinity mark when range switch is changed.

1. Replace V2. See "Tube Replacement". NOTE: (A small deviation should be considered acceptable.)
2. Excessive leakage in ohms circuit, possibly caused by high humidity. Allow instrument to operate for several hours until dry.

AC-Voltage Function

Instrument fails to indicate on any ac-voltage range; works normally on OHMS and DC VOLTS.

1. V1 defective. See "Tube Replacement".
2. AC volts contact on switches may be defective.
3. Faulty wiper contact on S1, Sect. 2, front.
4. Open or short circuit in circuitry associated with V1. Check out wiring and components values with ohmmeter.
5. C1 or C2 open, C3 shorted, or R4 open.

Meter pointer moves off zero when ranges are changed.

1. "AC BAL" potentiometer out of adjustment. Readjust as described under "AC Balance Adjustment." If adjustment cannot be made, then replace V1. See "Tube Replacement".
2. Resistor network around S1, Sect. 1, rear, is defective. Check continuity and values with ohmmeter.

AC-voltage readings inaccurate on all ac ranges; performance on ohms and dc-voltage ranges is normal.

1. V1 defective. Install new 6AL5. See "Tube Replacement".
2. Check C1, C2, and C3.
3. R4 changed in value.

If instrument is inaccurate on 500 and 1500 volt ranges only, check R1, R2, R3, and C2. If inaccurate on 1.5 volt range only, replace V1. See "Tube Replacement".

AC and dc-voltage readings inaccurate on some or all ranges; resistance readings correct.

1. Resistor network around switch S1, Sect. 1, rear, defective. Check values with ohmmeter.
2. Defective contacts or wipers on switch S1, Sect. 1, rear. Check for loose or dirty contacts.
3. Excessive leakage in switch S1.

DC-Voltage Function

Instrument fails to indicate on any range of "+VOLTS" or "-VOLTS".

1. DC probe or cable is defective.
2. DC-voltage contacts on switch sections are defective. Check for loose or broken contacts.
3. Check R7 and switch S2, Sect. 1, front.

Instrument fails to indicate on any range of "+VOLTS" but normal on "-VOLTS" or vice versa; works normally on ohms and ac volts.

1. Defective contacts on switch section S2, Sect. 2, front. Check switch for loose or broken contacts.

Voltage readings inaccurate on "+VOLTS", "-VOLTS", or both; ac voltage and resistance readings are correct.

1. R7 out of adjustment. Reset as described under "DC Voltage Calibration".
2. Isolating resistor in probe has changed value. Measure resistance on OHMS function. NOTE: If one or more of the low-value resistors in the network around S1, Sect. 2, rear, have changed value, it is possible that the meter reading may be inaccurate on the 500 and 1500 volt ranges but the inaccuracy may not be apparent on the lower ranges.

DC and AC voltage readings incorrect; resistance readings correct.

1. Resistance in network around S1, Sect. 1, rear, has changed value. Check out with ohmmeter and replace defective resistors.
2. Switch contacts on S1, Sect. 1, rear, defective. Check for loose or broken contacts, or foreign material.

Instrument fails to function on ac and dc voltage measurements; works normally on ohms function.

1. Check S2, Sect. 2, front, and network around S1, Sect. 1, rear.