

OPERATION MANUAL

SPECTRUM ANALYZER MS610B/J/J1

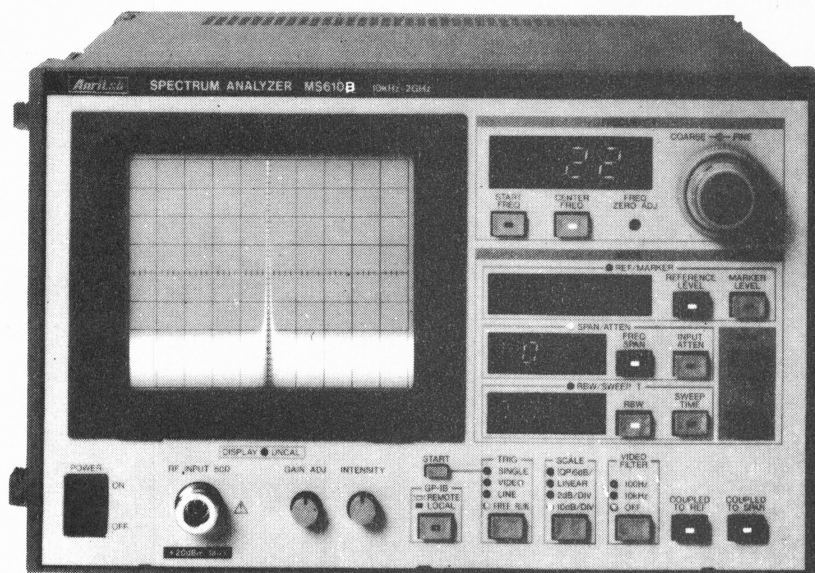

CERTIFICATION

ANRITSU CORPORATION certifies that this instrument has been thoroughly tested and inspected, and found to meet published specifications prior to shipping.

Anritsu further certifies that its calibration measurements are based on the Japanese Electrotechnical Laboratory and Radio Research Laboratory standards.

WARRANTY

All parts of this product are warranted by Anritsu Corporation of Japan against defects in material or workmanship for a period of one year from the date of delivery. In the event of a defect occurring during the warranty period, Anritsu Corporation will repair or replace this product within a reasonable period of time after notification, free-of-charge, provided that: it is returned to Anritsu; has not been misused; has not been damaged by an act of God; and that the user has followed the instructions in the operation manual.

Any unauthorized modification, repair, or attempt to repair, will render this warranty void.

This warranty is effective only for the original purchaser of this product and is not transferable if it is resold.

ALL OTHER EXPRESSED WARRANTIES ARE DISCLAIMED AND ALL IMPLIED WARRANTIES FOR THIS PRODUCT, INCLUDING THE WARRANTIES OF MERCHANTABILITY AND FITNESS FOR A PARTICULAR PURPOSE, ARE LIMITED IN DURATION TO A PERIOD OF ONE YEAR FROM THE DATE OF DELIVERY. IN NO EVENT SHALL ANRITSU CORPORATION BE LIABLE TO THE CUSTOMER FOR ANY DAMAGES, INCLUDING LOST PROFITS, OR OTHER INCIDENTAL OR CONSEQUENTIAL DAMAGES, ARISING OUT OF THE USE OR INABILITY TO USE THIS PRODUCT.

All requests for repair or replacement under this warranty must be made as soon as possible after the defect has been noticed and must be directed to Anritsu Corporation or its representative in your area.

Copyright © 1985 by ANRITSU CORP. Printed in Japan.
All rights reserved. No part of this manual may be reproduced in any form without written permission of ANRITSU CORP.

MANUAL CHANGE FOR THE MS610J1

1. Spectrum Analyzer MS610B/J Operation Manual (Index 1)

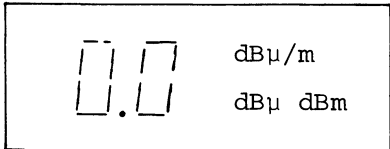
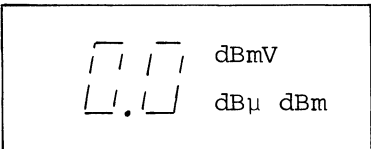
Page	MS610B/J	MS610J1
2- 4	Input Terminal dc max. ± 50 V	dc max. ± 100 V
3- 9	Fig. 3-3 	
3-10	(b) Setting range 10 dB/DIV and 2 dB/DIV sets 59 to 129 dB μ (MS610J) LINEAR set 49 to 129 dB μ (MS610J)	59 to 129 dB μ and -1 to 69 dBmV (MS610J1) 49 to 129 dB μ and -11 to 69 dBmV (MS610J1)
3-11	(c) Other functions dB μ /m	dB μ (where dB μ appears in field strength measurement, read dB μ as dB μ /m.)

(Continued)

Page	MS610B/J	MS610J1
------	----------	---------

3-16

Table 3-3

0 dBm is 107 dB μ for
MS610B (50 Ω), and
109 dB μ for MA610J
(75 Ω)

0 dBm=109 dB μ =49 dBmV
for MS610J1

3-22

Fig. 3-14

UNITS	
0	dBm
1	dB μ
2	dB μ /m (1)
3	dB μ /m (2)
4	dB μ /m (3)

(2) Setting

dB μ /m (1), (2), (3)

UNITS	
0	dBm
1	dB μ
2	dB μ (1)
3	dB μ (2)
4	dB μ (3)
5	dBmV

dB μ (1), (2), (3)

(where dB μ appears
in field strength
measurement,
read dB μ as dB μ /m.)

dBmV

displayed in dBmV
units.

2. MS610B/J GP-IB Interface Operation Manual -
Option 01 (Index 2)

Page	MS610B/J	MA610J1																										
4-15	4.4.18																											
	<table border="1"> <thead> <tr> <th>m</th> <th>LEVEL UNIT</th> </tr> </thead> <tbody> <tr> <td>0</td> <td>dBm</td> </tr> <tr> <td>1</td> <td>dBμ</td> </tr> <tr> <td>2</td> <td>dBμ/m (1)</td> </tr> <tr> <td>3</td> <td>dBμ/m (2)</td> </tr> <tr> <td>4</td> <td>dBμ/m (3)</td> </tr> </tbody> </table>	m	LEVEL UNIT	0	dBm	1	dB μ	2	dB μ /m (1)	3	dB μ /m (2)	4	dB μ /m (3)	<table border="1"> <thead> <tr> <th>m</th> <th>LEVEL UNIT</th> </tr> </thead> <tbody> <tr> <td>0</td> <td>dBm</td> </tr> <tr> <td>1</td> <td>dBμ</td> </tr> <tr> <td>2</td> <td>dBμ (1)</td> </tr> <tr> <td>3</td> <td>dBμ (2)</td> </tr> <tr> <td>4</td> <td>dBμ (3)</td> </tr> <tr> <td>5</td> <td>dBmV</td> </tr> </tbody> </table>	m	LEVEL UNIT	0	dBm	1	dB μ	2	dB μ (1)	3	dB μ (2)	4	dB μ (3)	5	dBmV
m	LEVEL UNIT																											
0	dBm																											
1	dB μ																											
2	dB μ /m (1)																											
3	dB μ /m (2)																											
4	dB μ /m (3)																											
m	LEVEL UNIT																											
0	dBm																											
1	dB μ																											
2	dB μ (1)																											
3	dB μ (2)																											
4	dB μ (3)																											
5	dBmV																											

3. MS610B/J Radio Interference Measuring Option
Operation Manual - Option 02 (Index 3)

Page	MS610B/J	MS610J1
4 - 3	dB μ /m	dB μ
4 - 4		(where dB μ appears in field strength measurement, read dB μ as dB μ /m.)
6 - 1	Notes: (1)	
	MS610J : 0 dBm=109 dB μ	MS610J1:
	MS610B : 0 dBm=107 dB μ	0 dBm=109 dB μ =49 dBmV

TABLE OF CONTENTS

INDEX 1	OPERATION MANUAL SPECTRUM ANALYZER MS610B/J
INDEX 2	OPERATION MANUAL SPECTRUM ANALYZER MS610B/J GP-IB INTERFACE (OPTION 01)
INDEX 3	OPERATION MANUAL MS610B/J RADIO INTERFERENCE MEASURING OPTION (OPTION 02)

OPERATION MANUAL
SPECTRUM ANALYZER
MS610B/J

ANRITSU CORP.

N o t e:

1. This instrument is operable on nominal voltages of 100 to 127 Vac or 200 to 250 Vac by changing the connections of the power transformer taps.

The voltage and current rating are indicated on the rear panel.

When changing voltages, change the connections of the power supply transformer, and the voltage and current designation plate on the rear panel. Order the plates from Anritsu Corp. if necessary.

2. In this manual, supply voltage and current rating are represented by [**] Vac and [***] A.
3. The relationships between power supply voltage and current rating are listed below.

** Vac	*** A
100 to 127 V	1.0 A
200 to 250 V	0.5 A

TABLE OF CONTENTS

	Page
SECTION 1 GENERAL	1-1
SECTION 2 COMPOSITION AND SPECIFICATIONS	
2.1 Composition	2-1
2.2 Specifications	2-2
2.3 Peripheral Devices and Accessories	2-6
2.3.1 MH680A/B Tracking Generator	2-6
2.3.2 MH648A Preamplifier	2-7
2.3.3 Artificial Mains Network	2-8
2.3.4 High Impedance Probe	2-8
2.3.5 Battery Pack and DC-DC Converter	2-9
2.3.6 Frequency counter	2-9
2.3.7 Antennas	2-10
2.3.8 Packet III Personal Technical Computer ..	2-11
2.3.9 Accessories	2-12
SECTION 3 OPERATION	
3.1 Handling Precautions	3-1
3.1.1 Power supply	3-1
3.1.2 Installation site environmental conditions	3-1
3.1.3 Maximum input level	3-2
3.2 Front and Rear Panel Controls	3-3

TABLE OF CONTENTS (continued)

	Page
3.3 Description of Controls	3-7
3.3.1 FREQUENCY	3-7
(1) COARSE-FINE dial	3-7
(2) START FREQ and CENTER FREQ	3-8
(3) FREQ ZERO ADJ	3-8
3.3.2 MODE	3-9
(1) Function	3-9
(2) DATA	3-9
(3) REFERENCE LEVEL	3-9
(4) MARKER LEVEL	3-10
(5) FREQ SPAN	3-11
(6) INPUT ATTEN	3-12
(7) RBW	3-13
(8) SWEEP TIME	3-13
3.3.3 COUPLED TO SPAN	3-14
3.3.4 COUPLED TO REF	3-16
3.3.5 VIDEO FILTER	3-17
3.3.6 SCALE	3-18
3.3.7 TRIG	3-19
3.3.8 DISPLAY UNCAL	3-20
3.3.9 GAIN ADJ	3-20
3.3.10 INTENSITY	3-21
3.3.11 GP-IB	3-21
3.3.12 REFERENCE LEVEL (rear panel)	3-22

TABLE OF CONTENTS (continued)

	Page
3.4 Measurement	3-23
3.4.1 Measurement preparation	3-23
(1) Power-ON	3-23
(2) Gain calibration	3-24
(3) Frequency display zero calibration	3-25
(4) TRACE ROTATION and V. POSITION adjustments	3-25
3.4.2 Fundamental measurement	3-26
3.4.3 Measurement with improved frequency accuracy	3-27
(1) Measurement with improved frequency accuracy using CAL OUT signal	3-27
(2) Measurement with improved frequency accuracy using MH680B and frequency counter	3-28
3.4.4 Spurious measurement	3-32
(1) Harmonics measurement with fast operation	3-32
(2) Inter modulation product measurement	3-34
(3) Random spurious signal measurement .	3-34
(4) Spectrum purity measurement	3-34
3.4.5 Modulated wave measurement	3-35
(1) Procedure	3-35
(2) AM wave measurement	3-35
(3) AM wave measurement when modulation frequency is low	3-37

TABLE OF CONTENTS (continued)

	Page
(4) FM wave measurement	3-38
(5) PAM wave measurement	3-39
(6) Audio modulation signal monitoring	3-40
3.4.6 Field strength measurement	3-42
(1) Measurement in dBμ units	3-43
(2) Direct reading measurement of field strength using specified antenna	3-43
(3) Antenna coefficient display	3-44
3.4.7 Radio interference (EMI) measurement	3-44
3.4.8 Measurement using GP-IB	3-44
 SECTION 4 DAILY MAINTENANCE AND STORAGE	
4.1 Daily Maintenance	4-1
4.2 Storage	4-1
4.2.1 Storage precautions	4-1
4.2.2 Recommended storage conditions	4-2
 SECTION 5 PRINCIPLES OF OPERATION	
5.1 Introduction	5-1
5.2 Frequency Conversion Circuit	5-2
5.3 IF Circuit	5-2
5.4 Detection and Video Circuits	5-3
5.5 Sawtooth Generator and Local Oscillator Control Circuit	5-3

TABLE OF CONTENTS (continued)

		Page
5.6	Controller	5-4
SECTION 6	PERFORMANCE TEST	
6.1	Introduction	6-1
6.2	Equipment Required for Performance Test	6-2
6.3	Preliminary Operations	6-5
6.4	Performance Test	6-5
6.4.1	CAL Output	6-5
6.4.2	Frequency display accuracy	6-8
6.4.3	Frequency span accuracy	6-11
6.4.4	Resolution bandwidth selectivity	6-13
6.4.5	Frequency stability	6-17
6.4.6	Residual FM	6-18
6.4.7	Sideband noise	6-21
6.4.8	LOG scale linearity	6-23
6.4.9	Reference level accuracy	6-25
6.4.10	Frequency response	6-27
6.4.11	Average noise level	6-30
6.4.12	2nd and 3rd harmonics distortion	6-31
6.4.13	Residual spurious response	6-34
6.4.14	Resolution bandwidth gain variation	6-35
6.4.15	RF input impedance (terminal)	6-37
6.4.16	Power consumption	6-41
6.4.17	Data sheets	6-42

TABLE OF CONTENTS (continued)

	Page
APPENDIX A BLOCK DIAGRAM	A-1

SECTION 1

GENERAL

The MS610B/J Spectrum Analyzer has a wide frequency range of 10 kHz to 2 GHz, and covers a broad range from the video to the UHF/VHF bands.

The MS610B/J also has a high harmonic dynamic range of 80 dB or more, so the time required for higher harmonic and spurious measurements is significantly reduced.

The coupled functions are provided to simplify operation. In the coupled mode, the only required operation is to set frequency, frequency span, and reference level.

The GP-IB and QP (Quasi Peak) detector for radio interference (EMI) measurement (options) are available for wider applications.

Frequency and frequency response can be accurately measured by using the MH680B Tracking Generator and a counter with the MS610B/J.

The MS610B/J is easy to transport, features compact design, is lightweight, and has low power consumption. It can also be operated on battery-power in the field.

The input impedances are 50 Ω for the MS610B, and 75 Ω for the MS610J.

Major applications:

- Spurious, distortion, and oscillation measurements for electronic devices and components.
- Accurate frequency measurements of unknown signals when used with the MH680B Tracking Generator and a counter.
- Accurate frequency response measurements for electronic components (filters, etc.) when used with the MH680B Tracking Generator and a counter.

- Impedance measurements for electronic components when used with the MH680A/B Tracking Generator and an impedance bridge.
- In-circuit measurements for electronic devices (printed circuit boards, etc.).
- Monitoring AM and FM signals for radio equipment.
- A variety of measurements (75 Ω) for CATV and broadcast satellites.
- EMI measurements (by QP detector option) conforming to CISPR specifications.

SECTION 2

COMPOSITION AND SPECIFICATIONS

2.1 Composition

The standard equipment and accessories are listed in Table 2-1.

Table 2-1 Standard Equipment and Accessories

Item	No.	Name	Qty.
Instrument	1	MS610B/J Spectrum Analyzer	1
Accessories	2	Coaxial Cable S-5DWP•5D2W•S-5DWP 1 m (for MS610B)	1
	3	Coaxial Cable BNC-P•RG-55/U•N-P 1 m (for MS610B)	1
	4	Coaxial Cable NC-P-3W•3C-2WS•NC-P-3W 1 m (for MS610J)	1
	5	Coaxial Cable BNC-P•3C-2WS•NC-P-3W 1 m (for MS610J)	1
	6	Power Cord	1
	7	Fuse ac *** A	2
	8	Operation Manual	1

2.2 Specifications

The specifications are listed in Table 2-2.

Table 2-2 Specifications

Frequency		
Frequency Range	10 kHz to 2 GHz	
Display and Accuracy	4-digit LED, resolution 1 MHz, CENTER/START switchability, accuracy of ± 10 MHz	
Frequency Span	Span *1	Zero and 0.1 MHz to 1 GHz, 1, 2, 5 sequence
	Full Span	0 to 2 GHz (with marker)
	Accuracy	$\pm 5\%$
Resolution	Resolution Bandwidth	1 kHz to 1 MHz (3 dB) 1, 3 sequence (For option 02, 9 kHz and 120 kHz: 6 dB bandwidth)
	Selectivity	$\leq 15:1$; 60 dB/3 dB bandwidth ratio (For 9 kHz and 120 kHz, 60 dB/6 dB bandwidth ratio)
Stability	Stability	≤ 50 kHz/5 minutes, one hour after power-on, for fixed frequency settings
	Residual FM	≤ 2 kHzp-p; sweep time ≤ 0.1 s
	Noise Sidebands	≤ -70 dB Resolution Bandwidth: 1 kHz Video Filter: 100 Hz 20 kHz from signal

*1. Span width is shown on a ten-section scale on the screen.

Table 2-2 (Continued)

Amplitude			
Measurement and CRT Display Range	LOG	10 dB/div	-115 to +20 dBm (MS610B)/-107 to +20 dBm (MS610J), CRT display range 72 dB
		2 dB/div	-66 to +20 dBm, CRT display range 16 dB
	LIN		-66 to +20 dBm, CRT display range 0 to 1
Log Scale Linearity			± 1.5 dB/72 dB ± 1 dB/16 dB
Frequency Response			± 1.5 dB (100 kHz to 1.5 GHz) $+2$ dB (1.5 to 2 GHz) -3 dB (1.5 to 2 GHz) When setting an input attenuator to 10 dB or more.
Reference Level *2		10 dB/div	-50 to +20 dBm in 1 dB steps
		2 dB/div	-50 to +20 dBm in 0.5 dB steps
		LIN	-60 to +20 dBm in 0.5 dB steps
		Accuracy	$\leq \pm 1.5$ dB
Dynamic Range	Average Noise Level		< -115 dBm (MS610B), < -107 dBm (MS610J) Resolution Bandwidth: 1 kHz Video Filter: 100 Hz Frequency: ≥ 1 MHz
	Second and Third Harmonic Distortion Factors		< 80 dB (5 to 800 MHz), < 70 dB (100 kHz to 1000 MHz) for -30 dBm input level Input attenuator: 0 dB
	Residual Spurious Response		< -100 dBm for 50 Ω /75 Ω Input Termination Input attenuator: 0 dB Frequency: ≥ 100 kHz
Video Filter			100 Hz, 10 kHz, OFF

*2. Reference level scale is the top horizontal line on the screen.

Table 2-2 (Continued)

Amplitude (Cont.)		
Resolution Bandwidth Gain Variation		±1 dB *3
Marker Level	Display	4-digit LED. The maximum level in the bright portion at the screen center is displayed.
	Resolution	0.1 dB Scale: 10 dB/Div and 2 dB/Div
Level Unit Switching		dBm, dBμ, dBμ/m
Coupled Function	COUPLED TO SPAN Resolution bandwidth and sweep time are optimized and set automatically by ganging with the FREQ SPAN. COUPLED TO REF Input Attenuator is optimized and set automatically by ganging with the REF LEVEL value. (Mixer level: ≤ -20 dBm)	
Input	Terminal	50 Ω, VSWR 1.5 or less, Type N-connector (MS610B) 75 Ω, VSWR 1.5 or less, Type NC-connector (MS610J) (when input attenuator is set to 10 dB or more), dc max. ±50 V
	Input Attenuator	0 to 50 dB in five 10 dB steps
Sweep	Time	10 ms to 99 s; 1, 2, 5 sequence; 13 steps
	Trigger	FREE RUN, LINE, VIDEO, SINGLE
Output	Calibrator	50 MHz ±150 kHz, -30 dBm ±0.5 dB, BNC connector
	XYZ axes	0 to 5 V, BNC connector
	Counter Control	TTL, BNC connector

*3. ±2 dB for 9 kHz resolution bandwidth.

Table 2-2 (Continued)

CRT	Graticule Division: 8 div x 10 div, 6-inch screen (diagonal measurement), P39 phosphor (medium persistence)	
External Control (for Option 01)	Compatible with IEEE STANDARD 488-1978, IEC625-1 Interface functions: SH1, AH1, T8, L4, SR0, RL1, PP0, PC1, DT0, C0. All functions except the power switch, CRT brightness, frequency zero adjustment, and gain adjustment volume, can be controlled. (Frequency setting control: resolution 1 MHz, accuracy ± 20 MHz)	
Detector-Time Constant (For Option 02)	Electrical Charge-time constant	1 ms
	Electrical Discharge-time constant	160 ms (for 9 kHz resolution bandwidth) 550 ms (for 120 kHz resolution bandwidth)
Mechanical Time Constant (For Option 02)	160 ms (for 9 kHz resolution bandwidth) 100 ms (for 120 kHz resolution bandwidth)	
Power	** Vac $\pm 10\%$, 50/60 Hz, 85 VA	
Dimensions and Weight	177H x 284W x 351D mm, 13.5 kg	
Rated Operating Temperature Range	0° to 50°C	
Options	01: GP-IB 02: QP (Quasi Peak) Detector	

2.3 Peripheral Devices and Accessories

To make use of the MS610B/J more effective, peripheral devices, application parts, and accessories are available. These are all sold separately.

2.3.1 MH680A/B Tracking Generator (100 kHz to 2 GHz)

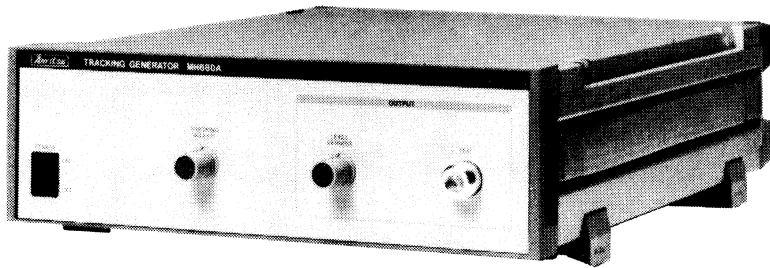

The MH680A/B Tracking Generator is a wideband sweep signal source for use with the MS610A/B Spectrum Analyzer. It allows direct reading measurement of the transmission characteristics of wideband amplifiers, filters, and circuit networks.

When the MH680A/B is used with Anritsu frequency counter, unknown signal frequency measurements and accurate center frequency adjustments of filters, are made possible (paragraph 3.4.3 (2)).

Frequency Range	100 kHz to 2 GHz
Output Level Range	-10 dBm to 0 dBm (Continuously variable)
Output Frequency Response	1 dB (at 0 dBm point)
Output Terminal	50 Ω , Type N connector

2.3.2 MH648A Preamplifier

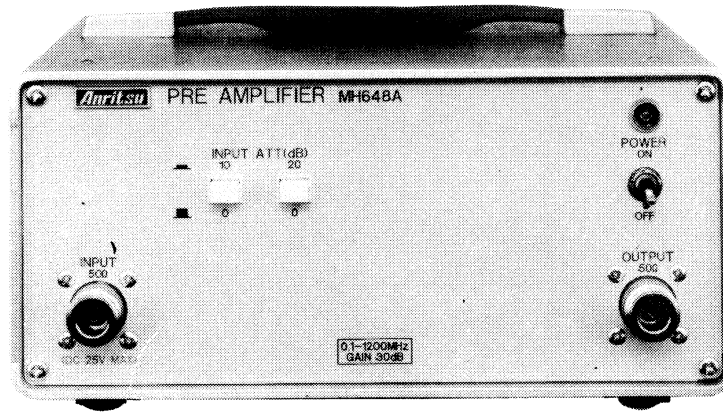

The MH648A Preamplifier improves the sensitivity of the MS610B/J Spectrum Analyzer by a maximum of 24 dB.

Frequency Range	0.1 to 1200 MHz
Gain	30 ±1 dB (0.5 to 800 MHz) 30 +1.5/-6 dB (0.1 to 1200 MHz)
Noise Figure	≤6 dB (0.5 to 800 MHz) ≤8 dB (0.1 to 1200 MHz)
Input Attenuator	0, 10, 20, 30 dB
Power	** Vac ±10%, 50/60 Hz, ≤10 VA or, +21 to +30 Vdc, ≤120 mA

2.3.3 Artificial Mains Network

Conducted EMI measurements at a frequency of ≤ 30 MHz are possible. The artificial mains networks specifications meet international standards for the following:

	MN423A	MN424A	MN425A
Frequency range	150 kHz to 30 MHz	450 kHz to 30 MHz	10 kHz to 30 MHz
Impedance	75 Ω	50 Ω	50 Ω
Application	CISPR Pub. 1	FCC Part 15	VDE 876

2.3.4 High Impedance Probe

High impedance can be measured without affecting the DUT (such as RF circuits) by using the High Impedance Probe. Select one of the following probes for the DUT being tested.

Model	Frequency range	Input level	Input capacitance	Input resistance	Insertion loss	Remarks
MA45B (Anritsu)	100 Hz to 30 MHz	2.74 Vrms max.	≤ 20 pF	≥ 3 M Ω	10 dB	Power supplied by power unit (MA45B accessory)
1121A Ac probe (HP)	1 kHz to 500 MHz	350 mVrms max.	≤ 3 pF	100 k Ω	0 dB	Power supplied by 1122A (HP) Power Supply.
P6008 (TEKTRONIX)	DC to 100 MHz	27.4 Vrms max. When connected to MS610B.	7.5 pF	≥ 10 M Ω	20 dB	Power supply not required.

Note:

To connect each probe to the MS610B, the N-BNC conversion connector must be used.

2.3.5 Battery Pack and DC-DC Converter

The instrument can be operated on dc power for measurements in the field and can be powered by batteries using the MZ144A Battery Pack. External power sources such as 12 V car batteries require the MZ145A DC-DC Converter.

Model	Specifications
Battery Pack MZ144A	Lead-acid battery: +12 V Output voltage: +24 V, -24 V Operation time: 3 hours or more, with built-in charger
DC-DC Converter MZ145A	Input voltage : +12 V Output voltage: +24 V, -24 V

2.3.6 Frequency counter

Frequencies can be accurately measured by using the following frequency counters with the MH680B Tracking Generator (paragraph 3.4.3 (2)).

Model		Frequency range	Gate time
MF57/58A	INPUT 1	10 Hz to 60 MHz	1 ms, 10 ms
	INPUT 2	30 to 600 MHz	1 ms, 10 ms
MF63/64A	INPUT 1	10 Hz to 1000 MHz	1 ms, 10 ms
	INPUT 2	30 to 1000 MHz	4 ms

2.3.7 Antennas

When the following antennas are used with the MS610B/J and Quasi Peak (QP) option, the measured radio interference and field strength can be read directly from the digital display.

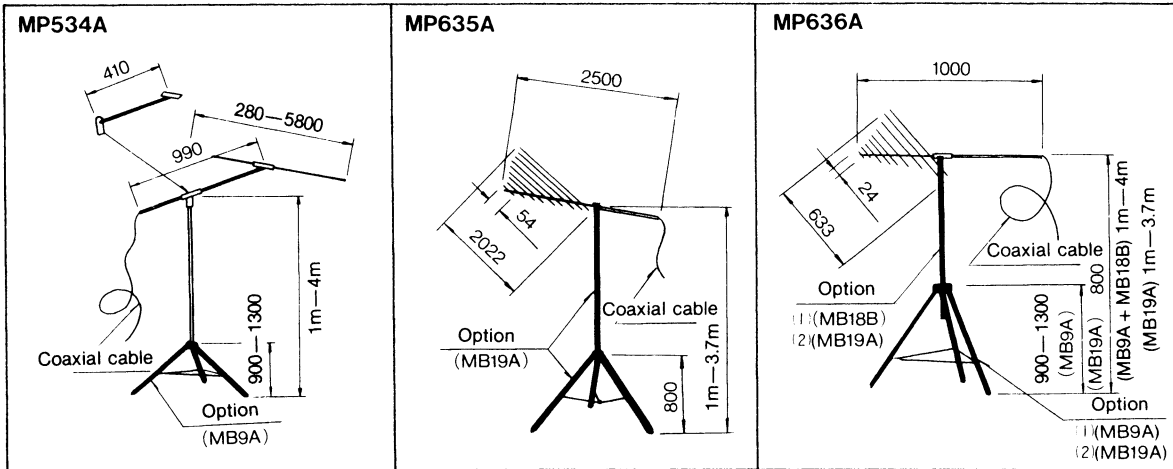

(Dimensions in mm unless otherwise indicated)

2.3.8 Packet III Personal Technical Computer

The Packet III is a personal computer for high-speed control and scientific applications. It has an MC68000 high-performance, 16-bit microprocessor and uses ANSI extended BASIC-based FDOS. Commands which facilitate measurement and control by using a GP-IB are provided, so the MS610B/J can be easily automated and remotely controlled by installing the GP-IB option which makes it perfect for adjustment and inspection labor-saving.

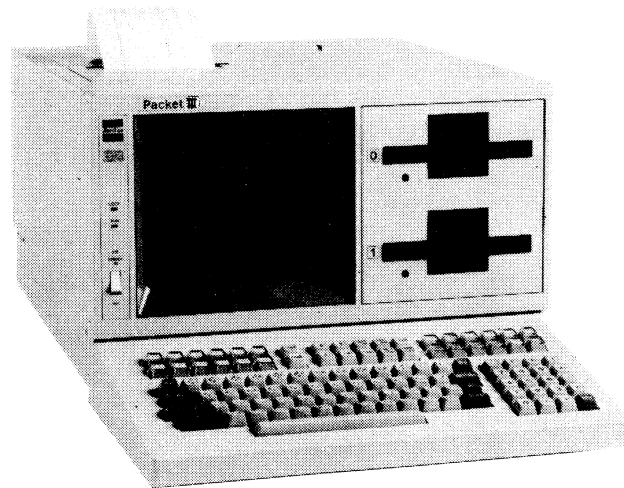

2.3.9 Accessories

(1) CRT filter

This filter can be easily fitted and removed. If specific lines are drawn directly on the filter, quality judgement, etc. is easy.

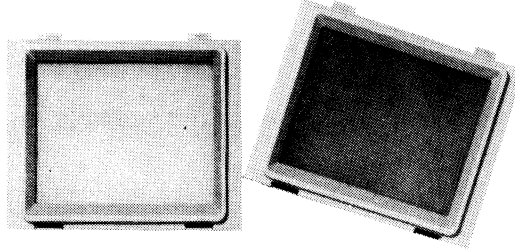

Name	Part Code	Remarks
CRT filter (Smoked)	B 0075	Color (Smoked)

(2) Carrying bag

A carrying bag, which is convenient for carrying the instrument in the field, for outdoor measurements, and for on-site maintenance service, is available.

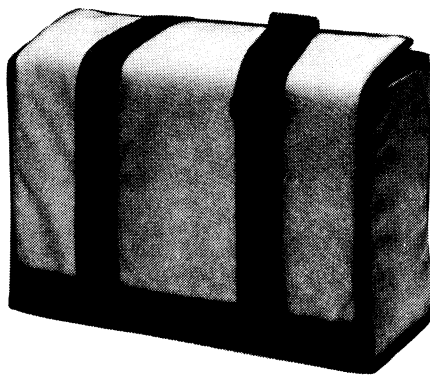

Name	Part Code	Remarks
Carrying bag	B 0076	Front Protection Cover Included

(3) Carrying case

These carrying cases are recommended for transporting the instrument by car, airplace, etc.

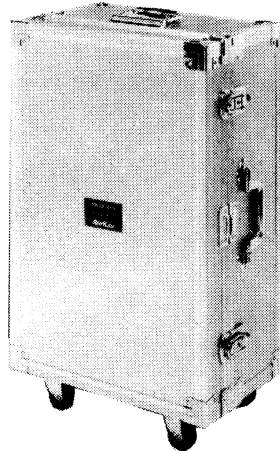

With Casters

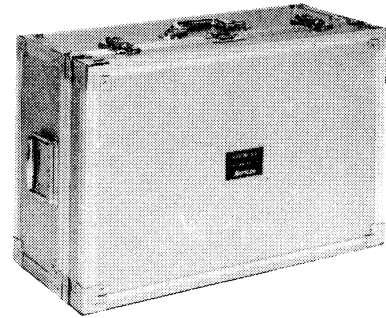

Without Casters

Name	Part Code	Remarks
Carrying case with casters	B 0077	Front and rear protection covers included
Carrying case without casters	B 0078	Front and rear protection covers included

Dimensions: 290H x 650W x 410D mm
(Excluding casters, handle, etc.)

SECTION 3

OPERATION

3.1 Handling Precautions

3.1.1 Power supply

The MS610B/J operates on 50 Hz/60 Hz ac voltage of $\pm 10\%$ of the value shown on the rear panel.

WARNING

1. To avoid accidental electric shock, when using a 2-pin power outlet, always ground the rear panel \perp terminal or the power cord ground terminal.
 2. Make sure the power switch is off and power supply cord unplugged when replacing fuses.
-

3.1.2 Installation site environment conditions

The MS610B/J operates normally at an ambient temperature of 0° to 50°C. However, do not use it in locations

1. where vibrations are severe
2. where it is damp and dusty
3. where there is exposure to direct sunlight
4. where there is exposure to active gases

CAUTION

If this instrument is operated at room temperature after being used or stored for a long period at low temperatures, condensation may occur and cause short-circuiting. To prevent this do not turn the power on until the instrument is completely dry.

3.1.3 Maximum input level

Do not input a level higher than +25 dBm because the internal circuits will be damaged.

3.2 Front and Rear Panel Controls

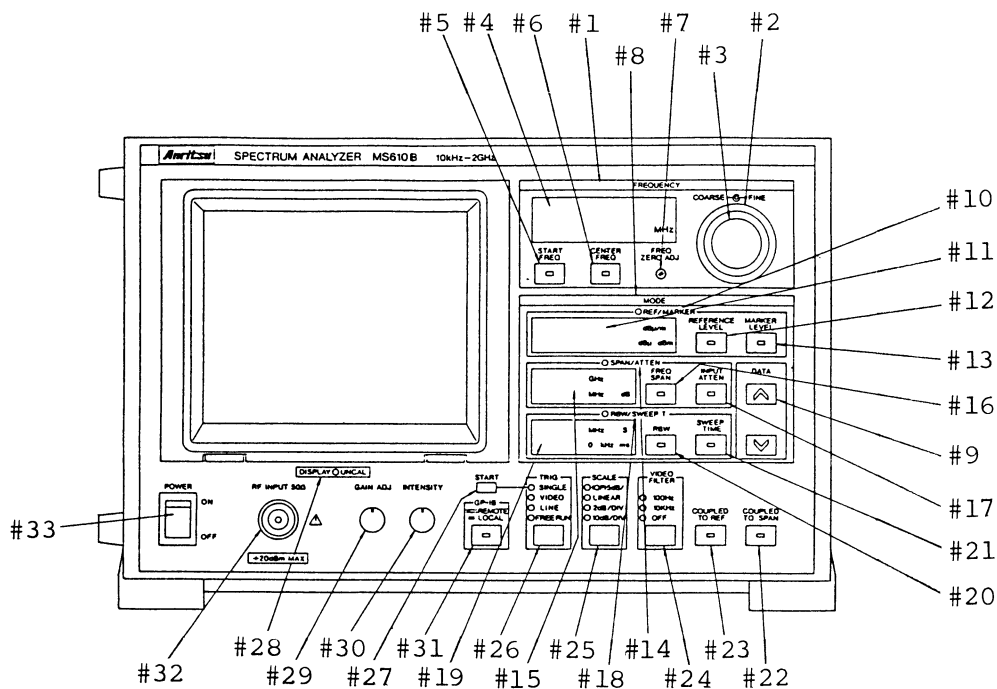

(a) Front

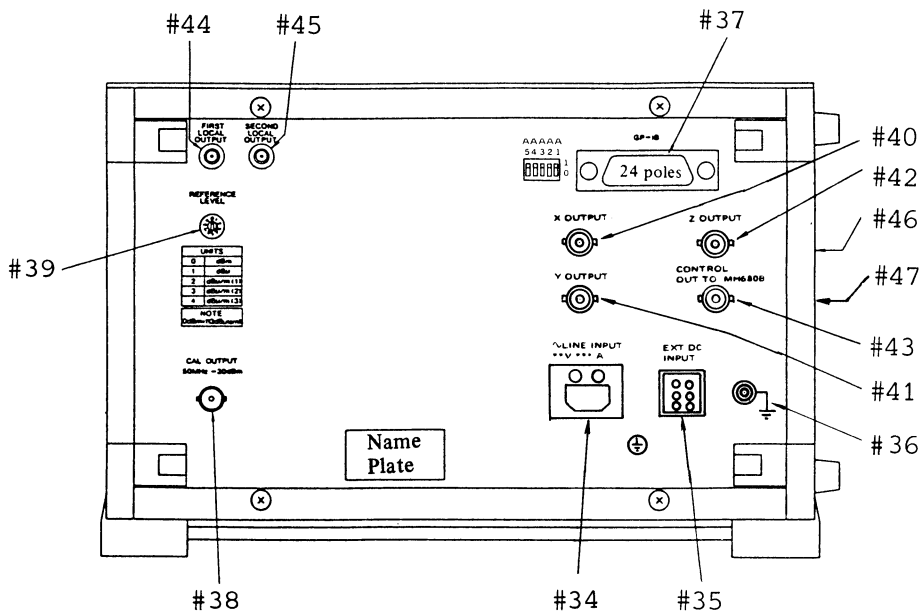

(b) Rear

Fig. 3-1 Front and Rear Panel Layouts

Table 3-1 Front and Rear Panel Control Functions

Section	Control	Function
FREQUENCY #1		This section contains the frequency-related functions.
	COARSE #2	Frequency coarse dial. 10 turns. All frequencies within 0 to 2 GHz settable.
	FINE #3	Frequency fine dial. 10 turns. Shifts the spectrum on the CRT within the 2 MHz range.
	(Frequency display) #4	Displays the frequency set by the COARSE dial. No relation to the FINE dial.
	START FREQ #5	Sets the displayed frequency at the screen START position.
	CENTER FREQ #6	Sets the displayed frequency at the screen CENTER position.
	FREQ ZERO ADJ #7	Calibrates the displayed frequency.
MODE #8		This section contains the screen-setting functions.
	DATA #9	Sets the measurement condition of the selected key in MODE.
	REF/MARKER #10	REFERENCE LEVEL LED, lights when REFERENCE LEVEL set.
	(Level display) #11	REFERENCE LEVEL or MARKER LEVEL display.
	REFERENCE LEVEL #12	Displays and sets the REFERENCE LEVEL.
	MARKER LEVEL #13	Outputs a brightened marker at the center of the screen. The peak level is displayed.
	SPAN/ATTEN #14	FREQ SPAN or INPUT ATTEN LED, lights when either key set.

Table 3-1 (Continued)

Section	Control	Function
MODE (cont.)	#8 (Span or atten. display)	#15 FREQ SPAN or INPUT ATTEN display.
	FREQ SPAN	#16 Sets and displays FREQ SPAN.
	INPUT ATTEN	#17 Sets and displays input attenuator set value.
	RBW/SWEEP T	#18 RBW or SWEEP TIME LED, lights when either key set.
	(RBW or sweep time display)	#19 Displays RBW or SWEEP TIME.
	RBW	#20 Sets and displays RBW 3 dB IF bandwidth.
	SWEEP TIME	#21 Sets and displays sweep time.
	COUPLED TO SPAN	#22 Automatically sets RBW and SWEEP T. to the optimum value corresponding to FREQ SPAN setting. The LED lights while this function is set.
	COUPLED TO REF	#23 Automatically sets INPUT ATTEN to the optimum value corresponding to REF level setting. The LED lights while this function is set.
	VIDEO FILTER	#24 Selects the VIDEO FILTER, the setting is indicated by the lit LED.
	SCALE	#25 Selects the screen vertical scale, the setting is indicated by the lit LED (5 dB can be set only when the QP [Quasi Peak] option is installed).
	TRIG	#26 Selects the trigger mode. The selected mode is indicated by the lit LED.
	START	#27 Starts the sweep when SINGLE is selected in TRIG mode.

Table 3-1 (Continued)

Section	Control	Function
MODE (cont.)	#8 DISPLAY UNCAL #28	Lights when the measured value (screen display) does not satisfy the measurement specifications.
	GAIN ADJ #29	Fine-adjusts the vertical gain (used in level calibration).
	INTENSITY #30	Adjusts the screen brightness (the marker brightness does not change).
	GP-IB #31	Changes the MS610B/J from the remote (controlled via the GP-IB) to the local state. The LED lights in the remote state (only when GP-IB option is installed).
	RF INPUT #32	Input terminal for measured signal
	POWER #33	Power switch
	~LINE INPUT #34	Ac power input with ac fuses
	EXT DC INPUT #35	Dc power supply input for dc operation
	 #36	Ground terminal
	GP-IB #37	Connector and address switch for GP-IB option
	CAL OUTPUT #38	Calibration signal output (50 MHz, -30 dBm)
	REFERENCE LEVEL #39	Switch for changing the REFERENCE LEVEL display units.
	X OUTPUT #40	X-axis output terminal
	Y OUTPUT #41	Y-axis output terminal
	Z OUTPUT #42	Z-axis output terminal
CONTROL OUT TO MH680B #43	Control signal output terminal to MH680B (used in frequency measurement).	

Table 3-1 (Continued)

Section	Control	Function
MODE (cont.)	#8 FIRST LOCAL OUTPUT #44	First local output terminal for the optional MH680A/B Tracking Generator
	SECOND LOCAL OUTPUT #45	SECOND LOCAL output terminal for the optional MH680A/B Tracking Generator. (The connectors corresponding to #44 and #45 are provided with the MH680A/B.)
	TRACE ROTATION #46	Adjusts the waveform tilt on the screen.
	V. POSITION #47	Adjusts the waveform VERTICAL POSITION on the screen.

3.3 Description of Controls

3.3.1 FREQUENCY

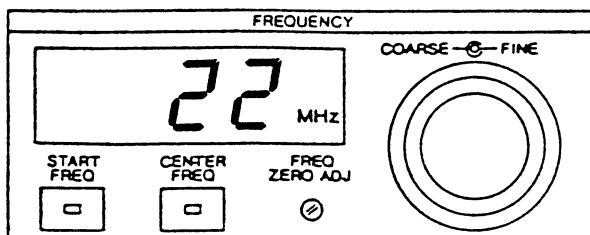

Fig. 3-2 COARSE and FINE Dials

(1) COARSE and FINE dials

(a) Function

Sets the frequency.

(b) Setting range

COARSE 0 to 2 GHz (all frequencies)
coarse adjustment dial

The complete frequency range can be set by 10 rotations of the dial. The frequency resolution is 1 MHz.

FINE

Fine adjustment dial

A 2 MHz range on the CRT display can be set by 10 rotations of the dial.

Displayed frequency is not changed by this dial.

(2) START FREQ and CENTER FREQ

(a) Function

Determines the display frequency position on the screen.

START FREQ Sets the displayed frequency at the screen START position.

CENTER FREQ Sets the displayed frequency at the screen CENTER position.

In FULL SCAN, both START FREQ and CENTER FREQ do not function.

(3) FREQ ZERO ADJ

(a) FUNCTION

Calibrates the display frequency.

(b) Adjustment method

In the CENTER FREQ mode, the zero beat is set to the screen center and this control is adjusted to the point at which the indicated frequency changes from 1 to 0 MHz.

3.3.2 MODE

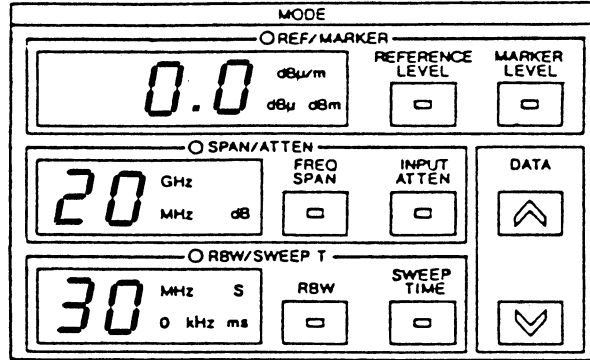

Fig. 3-3 MODE Keys

(1) Function

The display is divided into three areas designated REF/MARKER, SPAN/ATTEN, and RBW/SWEEP T each with an LED. Each area has two setting keys. When one key is pressed, an area lamp and key lamp lights. The DATA key mode is displayed along with the value.

(2) DATA

(a) Function

Sets the item of the pressed MODE key.
(Unrelated to MARKER LEVEL selection.)

(3) REFERENCE LEVEL

(a) Function

Displays the REFERENCE LEVEL; the value can be sequentially changed by DATA keys. (When the DATA key is held, the set value changes continuously.)

(b) Setting range

When SCALE 10 dB/DIV set -50.0 to +20.0 dBm,
57 to 127 dB μ
(MS610B), 59 to
129 dB μ (MS610J),
variable in 1 dB
steps

When SCALE 2 dB/DIV set -50.0 to +20.0 dBm,
57 to 127 dB μ
(MS610B), 59 to
129 dB μ (MS610J),
variable in 0.5 dB
steps

When LINEAR set (QP set) -60.0 to +20.0 dBm,
47 to 127 dB μ
(MS610B), 49 to
129 dB μ (MS610J),
variable in 0.5 dB
steps

(dBm and dB μ units can be exchanged by switching
the rear panel REFERENCE LEVEL switch.)

(4) MARKER LEVEL

(a) Function

Brightens the marker at the screen center and
displays the maximum level in the brightened portion.

(b) Setting range

The marker (brightened) should be set in the range below +1.9 dB of the REF LEVEL on the CRT when SCALE is 10 dB/DIV, and in the range from -19.9 to +0.3 dB of the REF LEVEL when SCALE is 2 dB/DIV. When this range is exceeded, the unit display flashes to indicate that the level display is unsuitable.

Notes:

1. Not operative in the LINEAR SCALE, FULL SPAN setting, when the REF/MARKER lamp is not lit.
2. Differs from FULL SPAN MARKER function.
3. Marker brightness is fixed; if INTENSITY is set too high, the marker cannot be seen.

(c) Other functions Field strength and interference measurements

When the rear panel rotary switch is set to dB μ /m (1), (2), (3), the measurement result for the field strength and interference, which is the maximum level on the brightest marker portion, is directly displayed in dB μ /m. For each antenna coefficient, when the \wedge key is pressed while the MARKER LEVEL key is pressed, only the antenna coefficient of the display frequency is displayed. When the \vee key is pressed, the display returns to the dB μ /m measurement display.

(5) FREQ SPAN

(a) Function

Displays the FREQ SPAN width which can be sequentially set with the DATA keys.

(b) Setting range

F (FULL SPAN 2 GHz), 1 GHz, 0.5 GHz, 0.2 GHz, 0.1 GHz, 50 MHz, 20 MHz, 10 MHz, 5 MHz, 2 MHz, 1 MHz, 0.5 MHz, 0.2 MHz, 0.1 MHz, and 0 MHz

(c) FULL SPAN MARKER

When set to F (FULL SPAN), a bright marker appears on the screen. This marker indicates the frequency (display frequency) set with the COARSE dial. When the center of the marker is set to the spectrum to be analyzed and SPAN is narrowed, the spectrum can be easily set at the screen center.

(6) INPUT ATTEN

(a) Function

Displays the input attenuator set value which can be set with the DATA keys incrementally or decrementally.

(b) Setting range

0, 10, 20, 30, 40, and 50 dB

The setting conditions depend on REF LEVEL and SCALE. Settable ranges are shown in the next page.

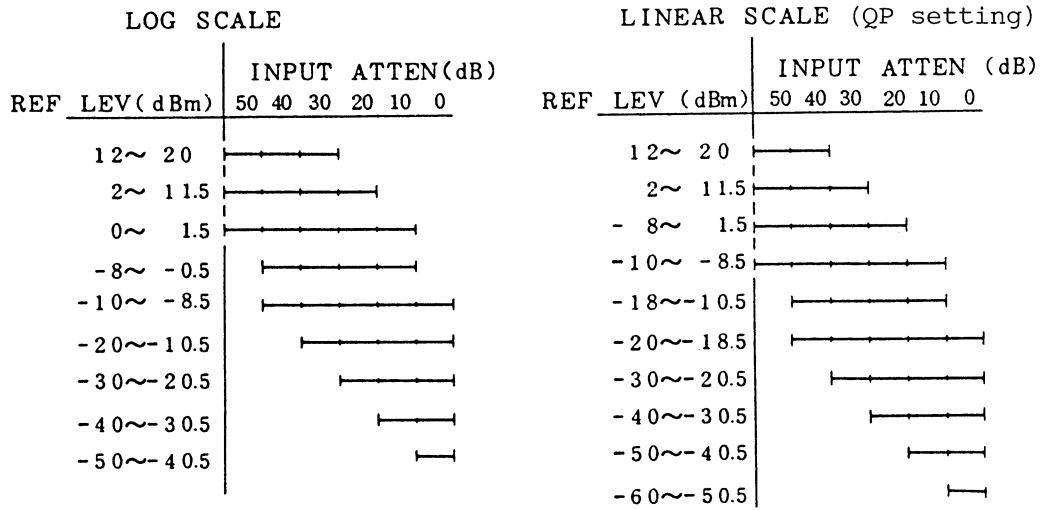

Fig. 3-4 INPUT ATTEN Range

0 dBm is 107 dBμ for the MS610B (50 Ω), and
109 dBμ for the MS610J (75 Ω)

(7) RBW

(a) Function

Displays RBW (IF 3 dB bandwidth) which can be sequentially set with the DATA keys.

(b) Setting range

1 MHz, 0.3 MHz, 120 kHz, 0.1 MHz, 30 kHz, 10 kHz, 9 kHz, 3 kHz, and 1 kHz (For 9 and 120 kHz, 60 dB/6 dB bandwidth ratio.)

(8) SWEEP TIME

(a) Function

Displays SWEEP TIME which can be sequentially set with the DATA keys.

(b) Setting range

99 s, 70 s, 60 s, 50 s, 40 s, 30 s, 20 s,
10 s, 5 s, 2 s, 1 s, 0.5 s, 0.2 s, 0.1 s, 50 ms,
20 ms, and 10 ms

At FULL SPAN and MARKER LEVEL, SWEEP TIME
≤50 ms cannot be set.

3.3.3 COUPLED TO SPAN



Fig. 3-5 COUPLED TO SPAN Key

(1) Function

RBW and SWEEP TIME are automatically set to the optimum state corresponding to the FREQ SPAN setting.

The SWEEP TIME is also set to the optimum state when the VIDEO FILTER is set.

(2) Setting

To make the setting, press the key so the key lamp is lit.

Even if the RBW or SWEEP TIME DATA keys have been previously set, pressing COUPLED TO SPAN sets them to the FREQ SPAN setting. RBW and SWEEP TIME are automatically changed corresponding to FREQ SPAN by the DATA keys; the SPAN/ATTEN area lamp lights. This function is reset and the lamp is turned off by pressing the set key again or by pressing the RBW or SWEEP TIME key.

Table 3-2 FREQ SPAN, RBW, and SWEEP TIME Relationships

FREQ SPAN	R.B.W	SWEEP TIME		
		V.F = OFF	V.F = 10 kHz	V.F = 100 Hz
F (2 GHz)	0.3 MHz	0.1 s	2 s	99 s
1 GHz	0.1 MHz	0.2 s	2 s	99 s
0.5 GHz	0.1 MHz	0.1 s	1 s	99 s
0.2 GHz	0.1 MHz	0.1 s	0.5 s	50 s
0.1 GHz	30 kHz	0.2 s	1 s	50 s
50 MHz	30 kHz	0.1 s	0.5 s	20 s
20 MHz	30 kHz	0.1 s	0.2 s	10 s
10 MHz	10 kHz	0.2 s	0.2 s	20 s
5 MHz	10 kHz	0.1 s	0.1 s	10 s
2 MHz	10 kHz	0.1 s	0.1 s	5 s
1 MHz	3 kHz	0.2 s	0.2 s	5 s
0.5 MHz	3 kHz	0.1 s	0.1 s	2 s
0.2 MHz	3 kHz	0.1 s	0.1 s	1 s
0.1 MHz	1 kHz	0.2 s	0.2 s	2 s
0 MHz	30 kHz	0.1 s	0.1 s	2 s

3.3.4 COUPLED TO REF



Fig. 3-6 COUPLED TO REF Key

(1) Function

INPUT ATTEN is automatically set to the optimum corresponding to REF LEVEL setting.

(2) Setting

To make the setting, press the key so the lamp is lit.

Even if the INPUT ATTEN DATA key has been previously set, pressing COUPLED TO REF sets REF LEVEL and INPUT ATTEN is automatically changed corresponding to REF LEVEL by the DATA keys; the REF/MARKER area lamp lights.

This function is reset and the key lamp is turned off by pressing the set key again or by pressing the INPUT ATTEN key.

Table 3-3 Relationship between REF LEVEL and INPUT ATTEN

REF LEVEL (dBm)	INPUT ATTEN (dB)	
	LOG SCALE	LINEAR SCALE
12 to 20	40	40
2 to 11.5	30	30
-8 to 1.5	20	20
-18 to -8.5	10	10
-28 to -18.5	0	0
-50 to -28.5	0	
-60 to -28.5		0

0 dBm is 107 dB μ for MS610B (50 Ω), and
109 dB μ for MS610J (75 Ω).

3.3.5 VIDEO FILTER

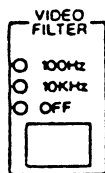

Fig. 3-7 VIDEO FILTER Key

(1) Function

Smooths noise and improves quality of waveform visibility.

(2) Setting

When the key is pressed, the video filter is set to OFF → 10 kHz → 100 Hz → OFF, in order, and the set value is indicated by the lamp.

OFF	Video filter not used.
10 kHz	10 kHz video filter used.
100 Hz	100 Hz video filter used.

3.3.6 SCALE

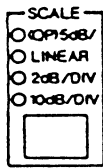

Fig. 3-8 SCALE Key

(1) Function

Sets the screen vertical axis scale.

(2) Setting

The scale is set in 10 dB/DIV → 2 dB/DIV → LINEAR → 10 dB/DIV, in order, and the set value is indicated by the lamp when the keys are pressed.

10 dB/DIV Screen full scale of 80 dB in the
10 dB/DIV scale

The top horizontal line is the reference level. The screen display range of 0 to -72 dB is calibrated. (0 dB is top horizontal line of screen display.)

2 dB/DIV Screen full scale of 16 dB in the
2 dB/DIV scale

LINEAR 1 to 0 display

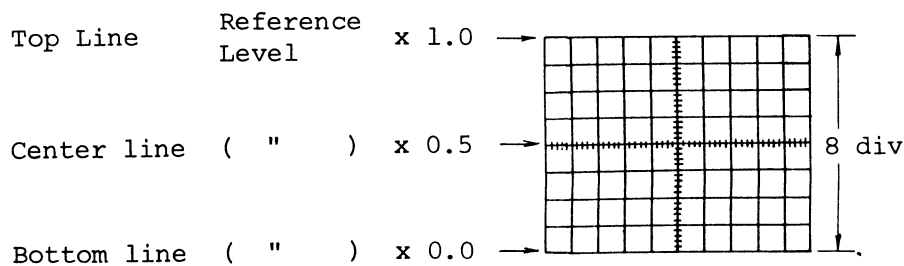

(QP) 5 dB/ Can be used in the EMI measurement (QP) option. Screen full scale of 40 dB in 5 dB/DIV scale.

3.3.7 TRIG

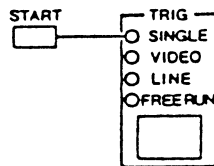

Fig. 3-9 TRIG Keys

(1) Function

Selects the sweep trigger mode.

The mode is set to FREE RUN → LINE → VIDEO → SINGLE → FREE RUN, in order, and the set mode is indicated by the lamp when the key is pressed.

When single mode is selected, sweep is performed by pressing the START key.

(2) Setting

FREE RUN	Sweep is repeated by the timing set internally.
LINE	Sweep is synchronized to the frequency of the ac line (power supply).
VIDEO	Sweep is synchronized to the video signal.
SINGLE	One sweep is performed by pressing the START key.

3.3.8 DISPLAY UNCAL



Fig. 3-10 DISPLAY UNCAL Lamp

(1) Function

When sweep is performed at a time shorter than the optimum SWEEP TIME determined by the FREQ SPAN, RBW, and VIDEO FILTER, the lamp lights to indicate that there is an error in the measured display value.

3.3.9 GAIN ADJ

GAIN ADJ



Fig. 3-11 GAIN ADJ Knob

(1) Function

Adjusts the gain. This is used to calibrate the absolute gain value and is also used when setting the displayed signal level to the scale on the screen, etc.

3.3.10 INTENSITY

INTENSITY



Fig. 3-12 INTENSITY Knob

(1) Function

Adjusts the image brightness on the screen.
The marker brightness does not change.

3.3.11 GP-IB



Fig. 3-13 GP-IB Key

(1) Function

Changes the remote state to the local state when the GP-IB option is installed and the GP-IB is used. In the remote state, the key lamp lights to indicate that GP-IB is being used. When set to the local state by pressing the key, the lamp goes out and the instrument can be used by manual key operation.

3.3.12 REFERENCE LEVEL (rear panel)

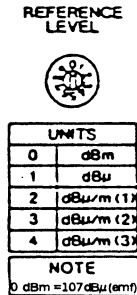

Fig. 3-14 REFERENCE LEVEL Switch

(1) Function

Changes the REFERENCE LEVEL display units.

(2) Setting

dBm	Displayed in dBm units.
dBμ	Displayed in dBμ units.
dBμ/m(1), (2), (3)	When the MARKER LEVEL is set to ON, the maximum level of the marker portion at the screen center is directly displayed in dBμ/m. After compensation corresponding to each standard antenna coefficient, the REFERENCE LEVEL is displayed in dBμ units.

3.4 Measurement

3.4.1 Measurement preparation

(1) Power-ON

After checking that the ac voltage of the power supply is within the specified value, insert the rear panel power cord into the power socket. When the power switch is set to ON, the LED on the display lights.

The display and setting are shown below:

Frequency Display	Frequency Dial Setting
START FREQ	OFF
CENTER FREQ	OFF
REFERENCE LEVEL display	0 dBm
FREQ SPAN	F (FULL)
INPUT ATTEN	20 dB
RBW	0.3 MHz
SWEEP T	0.1 s
COUPLED TO REF	ON
COUPLED TO SPAN	ON
VIDEO FILTER	OFF
SCALE	10 dB/DIV
TRIG	FREE RUN
GP-IB	OFF

Check these settings.

After several seconds, slowly turn the INTENSITY knob clockwise and adjust the brightness so that the display is easy to see.

(2) Gain calibration

To measure absolute level, calibrate the gain before making any measurements.

(a) Settings

CENTER FREQ	ON
COUPLED TO REF	ON
COUPLED TO SPAN	ON
REFERENCE LEVEL	-30 dBm
FREQ SPAN	5 MHz
VIDEO FILTER	OFF
SCALE	2 dB/DIV
TRIG	FREE RUN

(b) Connect the rear panel [CAL OUTPUT] connector to the front panel [RF INPUT] connector with the cable supplied. Set the center frequency display value to 50 MHz with the COARSE dial and adjust with the FINE dial to get a fundamental calibration signal wave at the center of the screen.

Next, turn the GAIN ADJ knob and set the top of the 50 MHz spectrum to the LOG reference line (the top horizontal scale line of the screen). This completes gain calibration.

(3) Frequency display zero calibration

Set the measurement parameters as follows:

(a) Settings

CENTER FREQ	ON
COUPLED TO REF	ON
COUPLED TO SPAN	ON
REFERENCE LEVEL	+10 dBm
FREQ SPAN	5 MHz
VIDEO FILTER	OFF
SCALE	10 dB/DIV
TRIG	FREE RUN

(b) Frequency display zero calibration

Set the FINE dial to five turns from the beginning. Then, turn the COARSE dial and display the zero frequency spectrum at the center of the screen.

Turn the FREQ ZERO ADJ semifixed variable resistor with a screwdriver and set it so that the frequency display changes from 1 to 0. This completes frequency display zero calibration.

(4) TRACE ROTATION and V. POSITION adjustments

(a) Setting

REFERENCE LEVEL	0 dBm
INPUT ATTEN	20 dB
FREQ SPAN	0 MHz
SCALE	LINEAR

(b) Adjustment

Adjust the TRACE ROTATION using a screwdriver to set the display line horizontally, then adjust V. POSITION to set it on the bottom horizontal scale line of the screen.

3.4.2 Fundamental measurement

The MS610B/J Spectrum Analyzer is equipped with coupled functions designed to enhance simplified operation and signal levels can be measured by simply setting the frequency, frequency span, and reference level, as follows:

Step	Procedure
1	Connect DUT X to the MS610B/J.
2	Turn the power switch on.
3	Select frequency as follows; At power-on initial setting, the frequency span is set automatically to FULL SPAN (F) and the full span marker will be displayed. Adjust the full span marker to meet the desired received signal by turning the COARSE and FINE dials.
4	Select frequency span as follows; COUPLED TO SPAN is automatically set to ON at power-on initial setting. Confirm that the FREQ SPAN lamp is lit. Then set to the desired frequency span by pressing the DATA key \wedge ; the resolution bandwidth (RBW) and sweep time are automatically set to the optimum value for the signal to be observed.
5	Select the reference level as follows; Press the REFERENCE LEVEL key. Then press the DATA key \wedge or \vee so that the top of the received signal trace is aligned with the reference level line (horizontal graticule line) at the top of the screen. At this time, COUPLED TO REF is set to ON. Therefore, a distortion of ≥ 70 dB can be measured.

(Cont.)

Step	Procedure
6	<p data-bbox="395 395 1209 425">Read the received signal level as follows;</p> <p data-bbox="395 459 1310 538">Press the MARKER LEVEL key. The zone marker is displayed at the center of the screen.</p> <p data-bbox="395 572 1430 651">Adjust the zone marker to meet the received signal by turning the COARSE and FINE dials.</p> <p data-bbox="395 685 1465 761">The signal level is digitally displayed in 0.1 dB steps on the REF/MARKER LED.</p>

3.4.3 Measurement with improved frequency accuracy

- (1) Measurement with improved frequency accuracy using CAL OUT signal

The specified center frequency accuracy of the MS610B/J is ± 10 MHz. However, frequency can be more accurately measured by using the CAL OUT signal.

The CAL OUT signal is connected to the RF INPUT by cable.

The n th harmonic spectrum of 50 MHz appears on the screen. When frequency deviation between the harmonic and the unknown signal is Δf , the frequency of the unknown signal is calculated to $50 n \pm \Delta f$.

The frequency accuracy of the harmonics of the CAL signal is ($n \times \pm 150$ kHz) for the n th harmonic; FREQ SPAN accuracy is $\pm 5\%$.

(2) Measurement with improved frequency accuracy using MH680B and frequency counter

By using the MH680B and an Anritsu counter, frequency can be measured with improved accuracy. When correctly calibrated, the frequency accuracy is within 3% of the frequency span width. The setup is shown in Fig. 3-15.

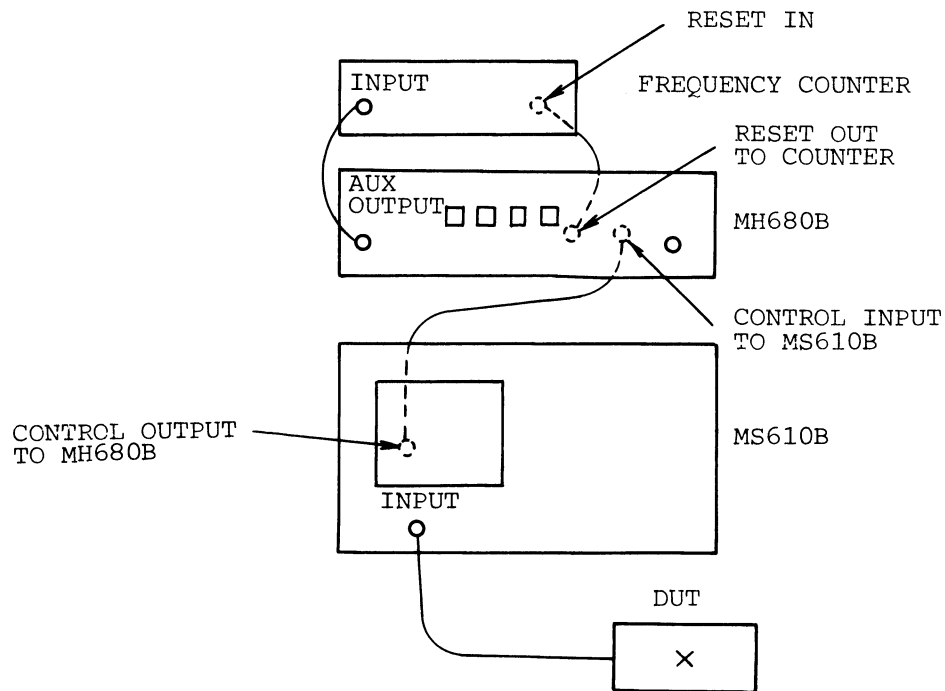

Fig. 3-15 Setup

(a) Frequency calibration

The frequency must be calibrated for each RBW setting of the MS610B. When RBW exceeds 100 kHz, calibrate at an RBW of 10 kHz.

Step	Procedure
1	Connect the MS610B RF INPUT connector to the MH680B OUTPUT connector using the supplied coaxial cable.
2	Set the MS610B as follows: FREQ SPAN 0 Hz RBW Set 10 kHz when the setting of the RBW to be measured exceeds 100 kHz. Otherwise, set to the RBW to be measured. SCALE 2 dB/DIV
3	Adjust the MH680B LEVEL VERNIER and the MS610B REFERENCE LEVEL as required so that the signal is displayed at the screen center.
4	Turn the MH680B TRACKING ADJ volume so that the displayed signal is at the maximum value.

(b) MH680B setting

Set the GATE TIME (ms) so that it matches the counter gate time.

GATE TIME range: 0.1, 1, 4, and 10 ms

When using an Anritsu counter, set as shown in the table below.

Table 3-4 Gate Time Setting

Type	Frequency Range	Counter Resolution Setting		MH680B GATE TIME setting
		Resolution	Gate Time	
MF57A/58A	10 Hz to 600 MHz	1 kHz	1 ms	1 ms
		100 Hz	10 ms	10 ms
MF63A/64A	Input 1 10 Hz to 60 MHz	1 kHz	1 ms	1 ms
		100 Hz	10 ms	10 ms
	Input 2 30 to 1000 MHz	1 kHz	4 ms	4 ms

When using another counter type, the MH680B volume must be adjusted.

(c) Frequency measurement

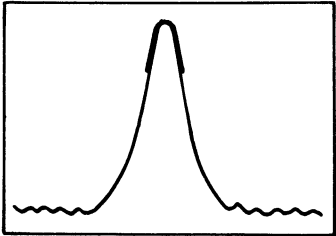
Step	Procedure
1	Receive the unknown signal at the MS610B screen center.
2	Set the sweep time to 0.1, 0.2, 0.5, or 1 s. If another sweep time is set, the counter will not operate. Note: Frequency measurement is more stable if a longer sweep time is set.
3	Set the MARKER on. The counter starts operating.
4	Turn the COARSE and FINE dials so that the received signal is set at the zone marker center as shown in Fig. 3-16.
	
Fig. 3-16 Zone Marker	
The accurate frequency of this signal is at the zone marker center.	
5	Read the counter displayed frequency.

3.4.4 Spurious measurement

Spurious signals can be measured with the COUPLED TO REF function, when INPUT ATTEN is correctly set and internal distortion is less than 70 dB. When not using the COUPLED TO REF function, the input signal and the spurious signals generated by the MS610B/J can be discriminated as follows.

The input signal displayed on the CRT does not change when INPUT ATTEN is changed. (INPUT ATTEN does not affect the value of REF LEVEL, but it automatically changes the IF gain.)

The internal spurious signals due to secondary distortion, displayed on the CRT, change equal to the amount of change (dB) of INPUT ATTEN; the internal spurious signals due to tertiary distortion, displayed on the CRT, change by twice the amount of change (dB) of INPUT ATTEN.

(1) Harmonics measurement with fast operation

By using the COUPLED TO REF function, harmonics ≥ 70 dB can be measured much faster than is normally possible. (When the COUPLED TO REF function is on, the mixer input level is automatically set to ≤ -20 dBm.) For harmonic distortion at this setting, ≥ 70 dB is confirmed at the frequency range of 5 to 800 MHz.)

- (a) Since the frequency is often known for this kind of measurement, the instrument is initially set as shown below; the unknown signal spectrum is displayed on the screen.

FREQ COARSE and FINE dials	Tuned to the fundamental wave of the unknown signal.
START FREQ	Set to ON.
COUPLED TO REF	Set to ON.
SPAN (COUPLED TO SPAN)	Set to the FREQ SPAN so that the fundamental wave and harmonics of the unknown signal can be displayed at the same time.

However, the sweep time should be decreased and the span should be made as narrow as possible to allow an easy-to-see display.

A narrower RBW than the specified RBW of COUPLED TO SPAN can be set as follows:

RBW	Set an optimum RBW to measure the unknown spurious signal.
SWEEP T	Set so that DISPLAY UNCAL lamp does not light.

- (b) The fundamental wave spectrum of the unknown signal is adjusted using REFERENCE LEVEL as shown in Fig. 3-17. When the fundamental wave and harmonics cannot be displayed simultaneously, measure the fundamental wave and the harmonics separately.

Calculate the distortion of all harmonics from the level difference between the fundamental wave and harmonics.

(2) Inter modulation product measurement

In this case, the screen display shown in Fig. 3-18 is obtained by the display expansion measurement procedure (1) of paragraph 3.4.5 and the level of each spectrum is measured.

(3) Random spurious signal measurement

There are many occasions when the frequency and level of spurious signals, such as parasitic oscillation, etc., are unknown; the signal is displayed on the screen and measured as described in paragraph 3.4.2.

(4) Spectrum purity measurement (sideband noise)

Sideband noise is measured by expanding the spectrum as in procedure (1) of paragraph 3.4.5.

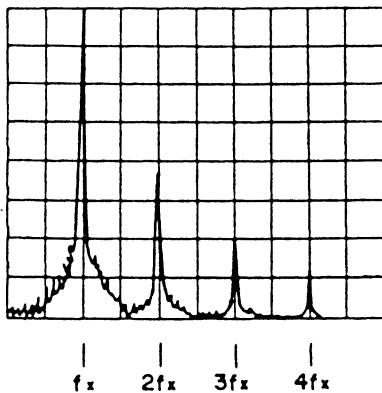

Fig. 3-17 Harmonics Spectrum

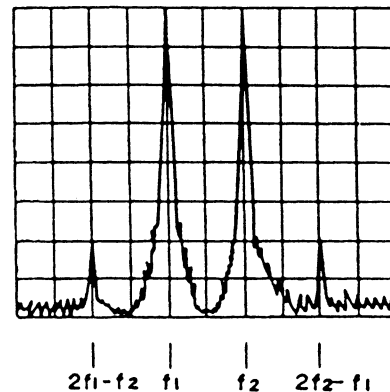

Fig. 3-18 Inter Modulated Wave Spectrum

3.4.5 Modulated wave measurement

The sideband spectrum of AM, PAM (Pulse amplitude modulation), FM, and other modulated waves is distributed above and below the carrier so the spectrum is measured by expanding the display on the screen with almost the same procedure as follows.

(1) Procedure

Step	Procedure
1	Set the instrument to the FULL SPAN mode, and receive the unknown signal.
2	Set the FULL SPAN MARKER to the spectrum to be measured using the COARSE dial.
3	Set COUPLED TO SPAN. Narrow the FREQ SPAN and expand the spectrum while setting the spectrum center to the screen center using the COARSE and FINE dials.
4	REF LEVEL is adjusted so that the amplitude of the spectrum is on the screen.

(2) AM wave measurement

When an AM wave is displayed, as shown in Fig. 3-19, the carrier frequency f_c , modulation frequency f_m , and their levels P_c , P_1 , and P_2 (dBm or dBμ) can be measured by the measurement procedure described in (1).

The 2nd harmonic distortion of the modulation wave is given as $(P_1 - P_2)$.

The modulation factor is calculated by using the equation:

$$20 \log m/2 = P_c - P_1$$

This relationship is shown in Fig. 3-20. When SCALE 10 dB/DIV is used, since the highest 70 dB level difference is read directly from the screen, a low modulation percentage (as low as 0.06%) can be measured.

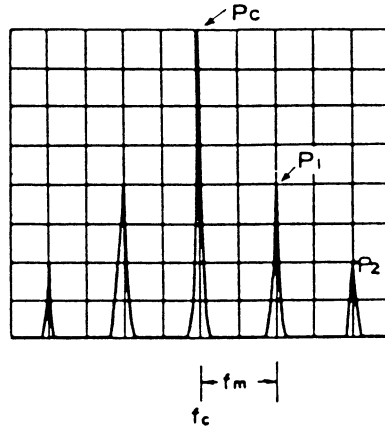

Fig. 3-19 AM Wave Spectrum

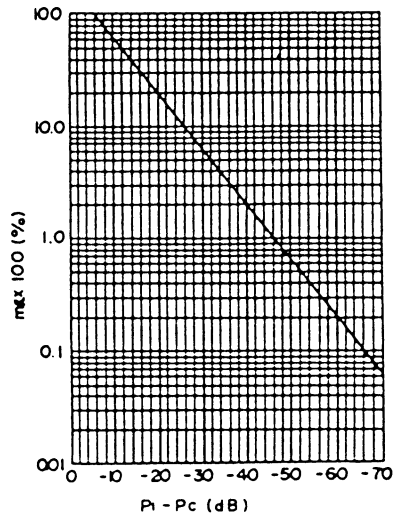

Fig. 3-20 AM Wave Modulation Factor and Sideband dB Display Level

(3) AM wave measurement when modulation frequency is low

When the modulation frequency is low and AM wave measurement analysis (2) is impossible, the **FREQ SPAN** setting is set to **ZERO SPAN** and the spectrum analyzer is operated as a fixed frequency receiver.

Set the following in addition to those of item (1):

SCALE	LIN
SPAN	0 (COUPLED TO SPAN)

When **REF LEVEL** is set to a suitable value and tuned with the **FINE** dial, the modulated signal waveform will appear on the screen. When the **TRIG** key is then set to **VIDEO**, the instrument is synchronized to the received signal and a static waveform appears as shown in Fig. 3-21.

Since the horizontal axis is determined by **SWEEP TIME**, the display becomes a time domain display from which the period **T** (seconds) of the received signal can be directly read.

The modulation frequency f_m is given by
 $f_m = (1/T) \text{ (Hz)}$. The modulation factor m is obtained
 from E_{max} , E_{min} , and E_c of Fig. 3-21 as follows:

$$m = (E_{max} - E_c) / E_c = (E_c - E_{min}) / E_c$$

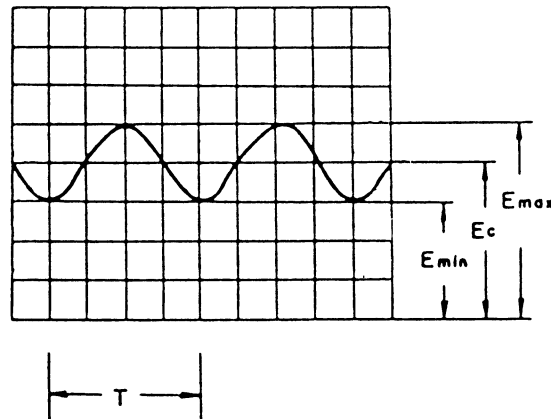

Fig. 3-21 AM Wave Time Domain Display

(4) FM wave measurement

The carrier frequency f_c , modulation frequency f_m , and the level of each sideband spectrum can be measured, when displayed as shown in Fig. 3-22 by the display expansion measurement procedure of item (1).

Since the FM wave zero carrier amplitude can be checked from the spectrum displayed on the screen, the FM wave modulation index can be calibrated.

The modulation index at which the carrier amplitude becomes zero is shown in Table 3-5.

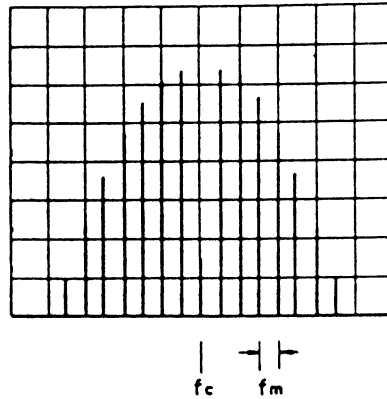

Fig. 3-22 FM Wave Spectrum

Table 3-5 Modulation Index When Carrier Amplitude Becomes Zero

Carrier Zero Order	Modulation Index
1	2.40
2	5.52
3	8.65
4	11.79
5	14.93
6	18.07
$n (n > 6)$	$18.07 + \pi (n - 6)$

(5) PAM wave measurement

The spectrum display of a PAM wave like that shown in Fig. 3-23 is obtained by the measurement display expansion procedure of item (1). The pulse width τ of the modulation pulse is obtained from the difference frequency f_r between the discontinuous points of the main lobe and side lobe of the pulse spectrum shown in Fig. 3-23 (a) ($\tau = 1/f_r$).

Furthermore, when each sideband spectrum is analyzed by expanding the spectrum, the spectrum display shown in Fig. 3-23 (b) is obtained and the carrier frequency f_c and pulse repetition frequency f_m are measured.

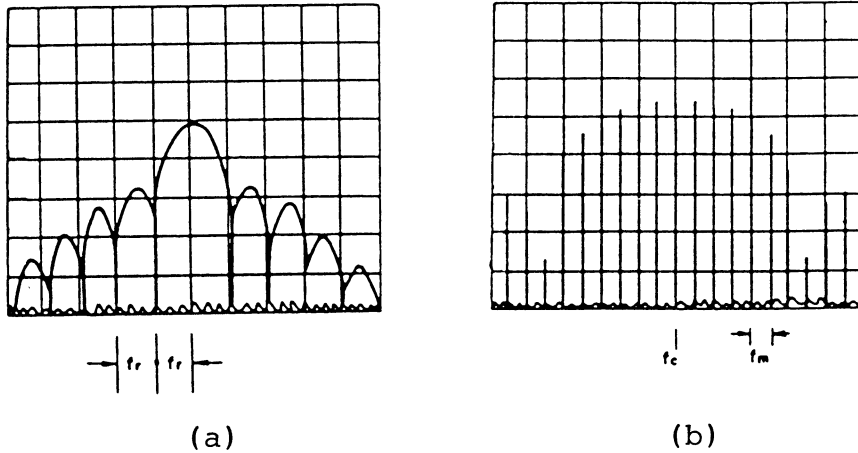

Fig. 3-23 PAM Wave Spectrum

(6) Audio modulation signal monitoring

Audio modulation signals of AM and FM waves can be monitored by using the Y-axis output and a speaker equipped with sound adjusting volume (recommended model: SC-A5).

(a) AM wave monitoring

Demodulate the AM wave by the 0 Hz Span linear mode as follows;

Step	Procedure
1	Receive the signal to be monitored at the screen center.

(Cont.)

Step	Procedure
2	Adjust the received signal at the 6 dB lower position from the reference level line by changing the reference level setting at 10 dB/DIV scale.
3	Set the Span to 0 (about 10 kHz is an adequate value for the resolution bandwidth).
4	Set SCALE to LIN.
5	Confirm that the demodulated AM wave is displayed on the screen.
6	Monitor the audio AM modulation signal by adjusting the speaker volume.

(b) FM wave monitoring

Demodulate the FM wave by the slope of the internal filter that determines resolution bandwidth as follows;

Step	Procedure
1	Receive the signal to be monitored at the screen center.
2	Adjust the received signal at the reference level line by changing the reference level setting at the 10 dB/DIV scale.
3	Set the Span to 0 (3 to 30 kHz is an adequate value for the resolution bandwidth).

(Cont.)

Step	Procedure
4	Set SCALE to LIN.
5	Confirm that the demodulated FM wave is displayed on the screen by tuning the COARSE and FINE dials.
6	Monitor the audio FM modulation signal by adjusting the speaker volume.

3.4.6 Field strength measurement

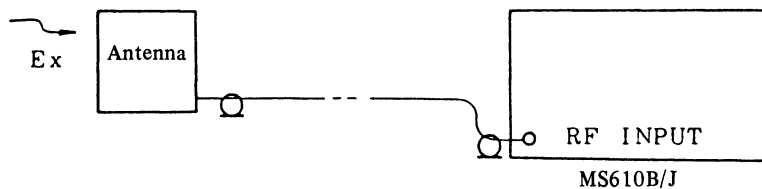

Fig. 3-24 Field Strength Measurement

In field strength measurement, the antenna (application parts) and the MS610B/J RF INPUT are connected with the cable as shown in Fig. 3-24 and an incoming electromagnetic wave is received.

In field strength measurement, the following conversion is necessary. But, if the antenna specified in Table 3-6 is used, the field strength can be read directly, without compensation.

$$E_x = P_x - K_o$$

P_x : Measured value

K_o : Antenna coefficient

- (1) Measurement in dB μ units
 - (a) The incoming electromagnetic wave is measured in dB μ units by using the REFERENCE LEVEL switch setting on the rear panel.
 - (b) The field strength is determined from the equation above and from the table supplied with the antenna.
- (2) Direct reading measurement of field strength using specified antenna

Step	Procedure
1	Set the REFERENCE LEVEL switch on the rear panel to the position matched to the specified antenna being used as indicated in Table 3-6.
2	Set the incoming electromagnetic wave to be measured to the screen center using the REFERENCE LEVEL and COARSE and FINE dials.
3	Set the MARKER LEVEL key to ON.
4	The field strength, compensated for by the antenna coefficient for the marker frequency, is displayed in dB μ /m.
5	To reduce measurement error, displayed frequency calibration is necessary. Calibrate the displayed frequency by using an external oscillator or internal calibration signal output.

(3) Antenna coefficient display

When \wedge of the DATA keys is pressed when the MARKER LEVEL key is set to ON, only the antenna coefficient for the marker frequency is displayed.

To return to the dB μ /m measurement display, press the \vee key.

Table 3-6 Relationship between REFERENCE LEVEL Switch (rear panel) and Antenna

Switch	2	3	4
	dB μ /m(1)	dB μ /m(2)	dB μ /m(3)
Antenna	MP534A	MP635A	MP636A
Type	Dipole antenna	Log-periodic antenna	Log-periodic antenna
Frequency Range	25 to 520 MHz	80 to 1000 MHz	300 to 1700 MHz

3.4.7 Radio interference (EMI) measurement (Option 02)

The QP detector, which conforms to the CISPR specifications, is built-in to the MS610B/J, so radio interference (EMI) measurements that conform to the CISPR specifications can be made.

Refer to the Radio Interference Measuring Option Operation Manual for details of radio interference measurements.

3.4.8 Measurement using GP-IB (Option 01)

Data on the screen can be read by using the external control and marker functions of the MS610B/J with the GP-IB.

Refer to the GP-IB Interface Operation Manual for details of GP-IB operation.

SECTION 4

DAILY MAINTENANCE AND STORAGE

4.1 Daily Maintenance

Daily maintenance of the MS610B/J consists mainly of cleaning and exterior inspection.

Table 4-1 Daily Maintenance Schedule

Problem	Occurrence	Procedure
Dirt (external)	Before long-term storage.	Wipe with neutral detergent, etc.
Dust	When used in a dusty place; when dust is noticeable.	Open the cover and blow away the dust with compressed air, etc.
Loose screws	When found.	Tighten with a screwdriver or other tools.

4.2 Storage

4.2.1 Storage precautions

When storing the instrument for an extended period of time;

1. Always clean it thoroughly before storage.
2. Do not store it at high temperatures ($\geq 55^{\circ}\text{C}$), high humidity ($\geq 90\%$), or excessively low temperatures ($\leq -25^{\circ}\text{C}$).
3. Do not store it in direct sunlight or in a dusty place.
4. Do not store it where it may be affected by condensation or corrosive gases.

4.2.2 Recommended storage conditions

In addition to the conditions listed above, the following environmental conditions are recommended when storing the instrument for an extended period of time.

Temperature: 0° to 30°C

Humidity: 40% to 80%

The storage area should not be subject to large fluctuations in temperature and humidity during a 24-hour period.

SECTION 5

PRINCIPLES OF OPERATION

5.1 Introduction

The MS610B/J is a superheterodyne type scanning spectrum analyzer. The block diagram is shown in Fig. 5-1. (The detailed block diagram is shown at the end of this manual, as APPENDIX A.)

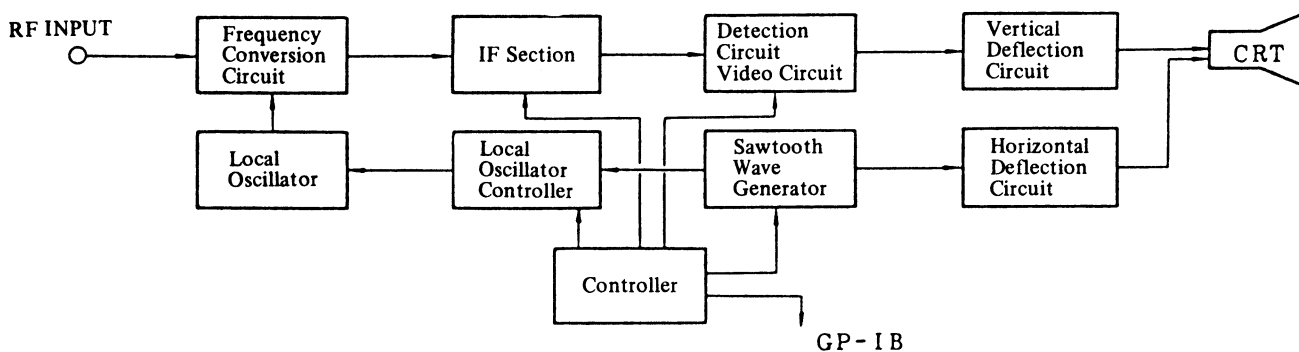

Fig. 5-1 MS610B/J Block Diagram

The input signal is converted to an IF signal by the frequency conversion circuit mixer. This IF signal is detected and is applied to the vertical deflection plate of the CRT. The sweep signal is generated by a sawtooth wave generator and is applied to the horizontal deflection plate of the CRT. This sweep signal simultaneously sweeps the local oscillator, and frequency sweep corresponding to the horizontal axis of the CRT is performed. Each section is controlled by a controller using a microcomputer.

5.2 Frequency Conversion Circuit

The MS610B/J is a triple superheterodyne system. The input signal is converted to a 3.5 MHz IF signal after triple frequency conversion as shown in Fig. 5-2. After the input signal is beat-up to 2.5214 GHz to prevent image response, it is converted to 21.4 MHz, and then converted to 3.5 MHz.

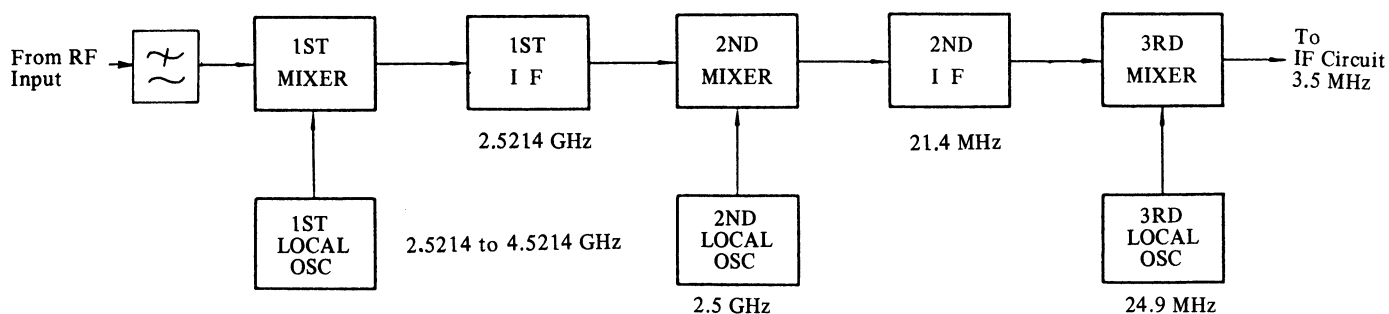

Fig. 5-2 MS610B/J Frequency Conversion Circuit

5.3 IF Circuit

The composition of the IF circuit is shown in Fig. 5-3.

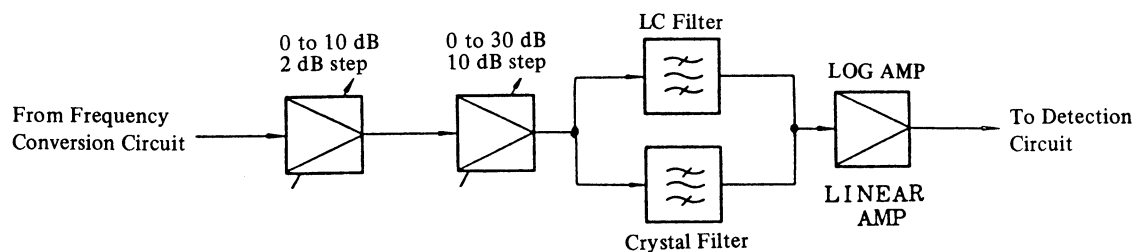

Fig. 5-3 MS610B/J IF Circuit

After the 3.5 MHz IF signal is passed through a 2 dB step 0 to 10 dB variable gain amplifier, and a 10 dB step 0 to 30 dB variable gain amplifier, it is sent through the LC filter and crystal filter.

The crystal filter determines the 1 to 3 kHz bandwidth and the LC filter determines the 10 kHz to 1 MHz bandwidth. The signals from these filters are amplified by the LOG and LINEAR amplifiers which determine the vertical axis scale.

5.4 Detection and Video Circuits

The 3.5 MHz signal from the IF circuit is detected by the detection circuit and amplified to 0 to 4 V by the video circuit.

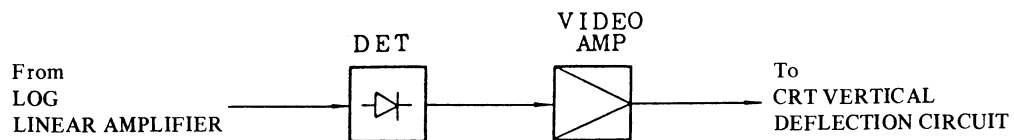

Fig. 5-4 MS610B/J Detection and Video Circuits

5.5 Sawtooth Generator and Local Oscillator Control Circuit

The sweep time is determined by the SWEEP TIME switch; the sawtooth wave signal sweeps the 1st local oscillator through the FREQ SPAN switch, which controls the FREQ SPAN. The SWEEP TIME switch and FREQ SPAN switch are controlled by the controller. The sawtooth wave signal also sweeps the CRT horizontal axis.

A YTO tuned coil is used in the 5 MHz to 2 GHz wide band sweep and a YTO FM coil is used in the 100 kHz to 2 MHz narrow band sweep.

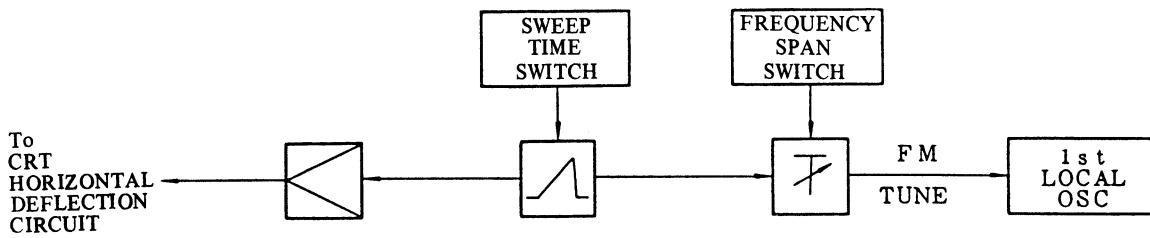

Fig. 5-5 MS610B/J Sawtooth Generator and Local Oscillator Control Circuit

5.6 Controller

The MS610B/J uses a CPU controller. Each circuit is controlled via an interface circuit for panel key inputs. GP-IB control is also performed.

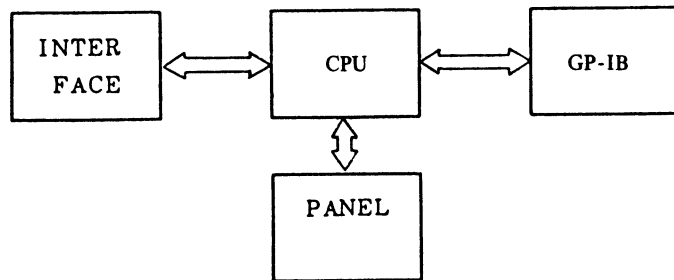

Fig. 5-6 MS610B/J Controller

SECTION 6
PERFORMANCE TEST

6.1 Introduction

This section describes the typical methods for testing the specified performance.

When the MS610B/J passes all the performance tests described in this section, it is operating normally. If any items do not satisfy the specifications, repair and adjust according to the separate Service Manual.

Table 6-1 List of Performance Test Items

Test Item Reference Paragraph	Test Contents
6.4.1	CAL Output
6.4.2	Frequency display accuracy
6.4.3	Frequency span accuracy
6.4.4	Resolution bandwidth selectivity
6.4.5	Frequency stability
6.4.6	Residual FM
6.4.7	Sideband noise
6.4.8	LOG scale linearity
6.4.9	Reference level accuracy
6.4.10	Frequency response
6.4.11	Average noise level
6.4.12	2nd and 3rd harmonics distortion
6.4.13	Residual spurious response
6.4.14	Resolution bandwidth gain variation
6.4.15	RF input impedance (terminal)
6.4.16	Power consumption
6.4.17	Data sheets

6.2 Equipment Required for Performance Test

Note:

Minimum specifications are the main parameters required for performance tests.

They are included to help select alternative equipment. Performance of alternative equipment should be checked before use.

Table 6-2 Equipment Required for Performance Test

No.	Equipment	Minimum Specifications	Recommended Model (Anritsu)
1	Signal Generator	Frequency range 100 kHz to 1 GHz Output level range -50 to +10 dBm Second harmonic ≤ -30 dBc	MG655A (50 Ω) MG645B (50 Ω)
2	Signal Generator	Frequency range 1.7 to 2.3 GHz Output level range ≥ 0 dBm	MG724A1 (50 Ω)
3	Signal Generator	Frequency range 10 MHz to 2 GHz Output level range ≥ 0 dBm	
4	Attenuator	Frequency range Dc to 500 MHz Impedance 50 Ω /75 Ω Step dial 10 dB x 8, 1 dB x 10 0.1 dB x 10, 3 dials With attenuator calibration data	MN510C/D

Table 6-2 (Continued)

No.	Equipment	Minimum Specifications	Recommended Model (Anritsu)
5	Frequency Counter	Measurement frequency 100 kHz to 1000 MHz Display 9 digits Accuracy ± 1 count + time base accuracy	MF63A
6	Frequency Counter	Measurement frequency 100 kHz to 18 GHz Accuracy ± 1 count + time base accuracy	MF76A
7	Power Meter with Power Sensor	Frequency Range 10 MHz to 2 GHz Measuring power range -20 to 0 dBm/ 50 Ω or 75 Ω Calibration accuracy 0.15 dB Recorder output	ML83A with MA72A (50 Ω)
8	Synthesizer/Level Generator	Frequency range 100 kHz to 10 MHz Maximum output level >0 dBm Digital sweep Start-stop sweep mode	MG443B (50 Ω /75 Ω)
9	Logarithmic Level Meter	(Wiltron, Model 501)	
10	VSWR Auto Tester	Frequency range 100 MHz to 2 GHz Impedance 50 Ω or 75 Ω	
11	Ac Meter	Ac Ammeter 0 to 10 A, $\pm 1\%$ Ac Voltmeter 0 to 300 V, $\pm 1\%$	
12	Termination	Frequency range Dc to 2 GHz Impedance 50 Ω or 75 Ω	MP752A (50 Ω)

Table 6-2 (Continued)

No.	Equipment	Minimum Specifications	Recommended Model (Anritsu)
13	Isolation Bridge		MP659A (50 Ω)
14	Low Pass Filter	Cutoff frequency 100 kHz to 1 GHz Attenuation >50 dB at $f_c/3$ to $f_c/\sqrt{2}$	
15	Power Splitter	Frequency range 10 MHz to 2 GHz Insertion loss 6 dB Output tracking <0.15 dB	
16	T-type Adapter	BNC(J) - BNC(J) - BNC(J)	
17	N(P) - N(P) Adapter	(Type N male to type N male)	
18	N(J) - N(J) Adapter	(Type N female to type N female)	
19	Impedance Converter	50 Ω to 75 Ω 10 kHz to 2 GHz	

6.3 Preliminary Operations

- (1) Turn on the MS610B/J and test equipment power.
- (2) Warm up the MS610B/J and test equipment for 30 minutes or more.

Note:

In the frequency stability test, warm up the MS610B/J according to the performance check procedure.

6.4 Performance Test

Unless otherwise specified, verify the results of each test and troubleshoot whenever the test specification is not met.

6.4.1 CAL Output

- (1) Specification

Level: -30 dBm \pm 0.5 dB

Frequency: 50 MHz \pm 150 kHz

Data sheet: Table 6-4

(2) Setup

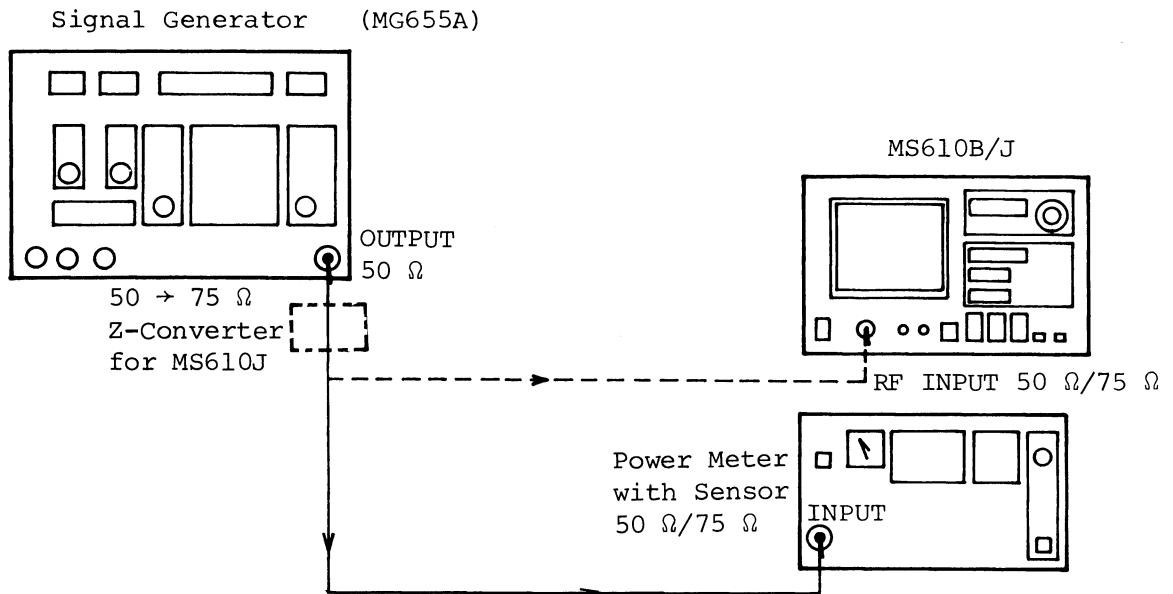

Fig. 6-1 CAL Output Level Test Setup

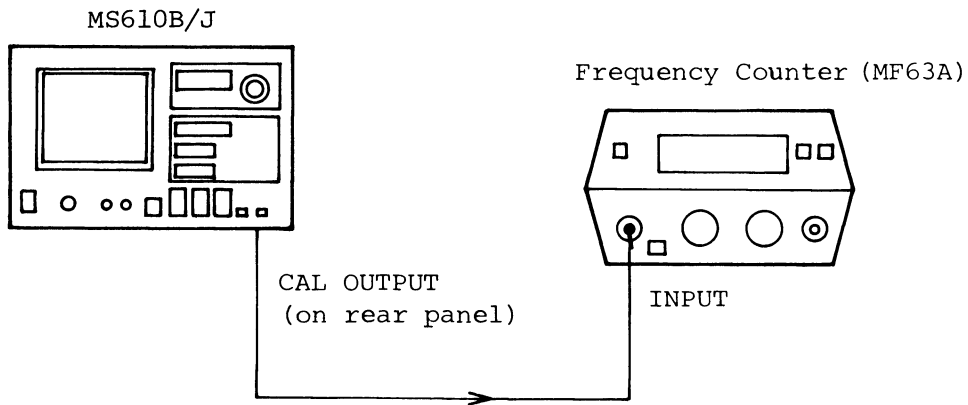

Fig. 6-2 CAL Output Frequency Test Setup

(3) Procedure

Procedure 1 (Output level)

Step	Procedure
1	Calibrate a 50 MHz -30 dBm output from the signal generator (MG655A) using a power meter.
2	Set the MS610B/J as follows: COUPLED TO REF ON COUPLED TO SPAN ON REFERENCE LEVEL -30 dBm FREQ SPAN 50 MHz SCALE 2 dB/div
3	Receive the calibrated 50 MHz, -30 dBm output (step 1) by the MS610B/J. Turn the MS610B/J GAIN ADJ volume to align the calibrated output spectrum with a proper horizontal scale line of the CRT.
4	Connect the MS610B/J CAL OUT output to the RF INPUT connector using the attached cable.
5	Read the level difference between the received spectrums of the MS610B/J CAL output and the calibrated 50 MHz output from the signal generator. Confirm that the level difference is less than ± 0.5 dB.

Procedure 2 (Output frequency)

Step	Procedure
1	Connect the MS610B/J CAL OUT to a frequency counter.
2	Read the CAL OUT frequency using the counter. Confirm that the CAL OUT frequency is within 50 MHz \pm 150 kHz.

6.4.2 Frequency display accuracy

(1) Specification

$$\leq \pm 10 \text{ MHz}$$

Data sheet: Table 6-5

(2) Setup

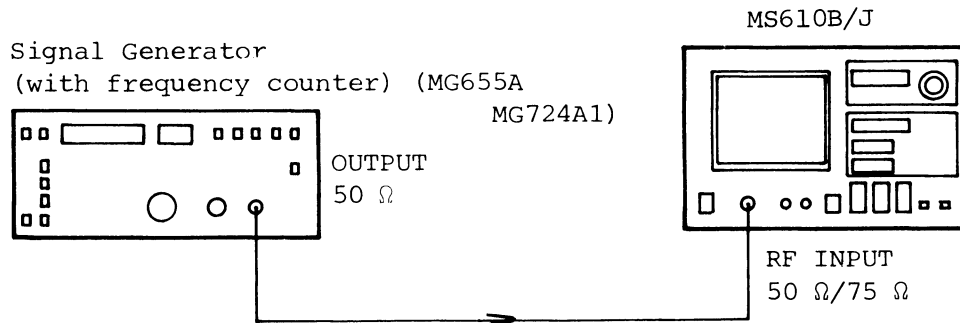

Fig. 6-3 Frequency Display Accuracy Test Setup

(3) Procedure

Step	Procedure
	(Frequency display zero calibration)
1	Set the MS610B/J as follows: CENTER FREQ ON COUPLED TO REF ON COUPLED TO SPAN ON REFERENCE LEVEL +10 dBm FREQ SPAN 5 MHz VIDEO FILTER OFF SCALE 10 dB/div TRIG FREE RUN
2	Turn the FINE dial clockwise to five rotations from the start. Then, turn the COARSE dial and display the zero frequency spectrum at the center of the screen.
3	Turn the FREQ ZERO ADJ semifixed variable resistor with a screwdriver and set it so that the frequency display LED changes from 1 to 0. This completes frequency display zero calibration.
	(Test)
4	Set the MS610B/J as follows: CENTER FREQ 1000 MHz FREQ SPAN 0.2 GHz
5	Set the signal generator output as follows: FREQUENCY (CW) approx. 1000 MHz (CENTER FREQ) LEVEL 0 dBm

(Continued)

Step	Procedure
6	Fine-adjust the signal generator frequency so that the peak of the spectrum trace is at the center of the CRT. Read the signal generator frequency as the actual measured value. Confirm that the frequency (CENTER FREQ) is within 1000 ± 10 MHz.
7	Change the frequency span to 10 MHz and again fine-adjust the signal generator frequency so that the peak of the spectrum trace is at the center of the CRT. Read the signal generator frequency at this time. Confirm that the frequency (CENTER FREQ) is within 1000 ± 10 MHz.
8	Change the center frequency of the MS610B/J and the output frequency of the signal generator to 100 MHz. Fine-adjust the signal generator frequency so that the peak of the spectrum trace is at the center of the CRT; read the frequency. Confirm that the frequency is within 100 ± 10 MHz.
9	Change the center frequency of the MS610B/J and the output frequency of the signal generator to 2 GHz. Fine-adjust the signal generator frequency so that the peak of the spectrum trace is at the center of the CRT; read the frequency. Confirm that the frequency is within 2000 ± 10 MHz.

6.4.3 Frequency span accuracy

(1) Specification

$$\leq \pm 5\%$$

Data sheet: Table 6-6

(2) Setup

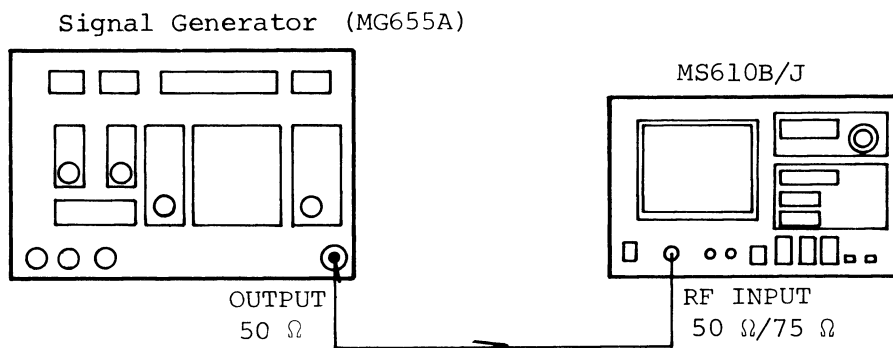

Fig. 6-4 Frequency Span Accuracy Test Setup

(3) Procedure

Step	Procedure						
1	Set the MS610B/J as follows: <table style="margin-left: 40px;"> <tr> <td>START/CENTER</td> <td>START</td> </tr> <tr> <td>FREQ SPAN</td> <td>1 GHz</td> </tr> <tr> <td>START FREQ</td> <td>500 MHz</td> </tr> </table>	START/CENTER	START	FREQ SPAN	1 GHz	START FREQ	500 MHz
START/CENTER	START						
FREQ SPAN	1 GHz						
START FREQ	500 MHz						
2	Setup as shown in Fig. 6-4 and set the signal generator as follows: <table style="margin-left: 40px;"> <tr> <td>Frequency</td> <td>1 GHz (The same frequency as the FREQ SPAN)</td> </tr> <tr> <td>Level</td> <td>0 dBm</td> </tr> </table>	Frequency	1 GHz (The same frequency as the FREQ SPAN)	Level	0 dBm		
Frequency	1 GHz (The same frequency as the FREQ SPAN)						
Level	0 dBm						

(Continued)

Step	Procedure
3	Turn the MS610B/J frequency dial to align the 1 GHz spectrum to the left-most vertical scale line of the CRT.
4	Read the frequency difference with the right-most vertical scale line (2 GHz in this case) of the CRT for the secondary harmonics spectrum of the 1 GHz signal. Confirm that the difference is less than $\pm 5\%$ of the FREQ SPAN.
5	Repeat Steps 2 to 4 according to the FREQ SPAN shown below.

0.1 MHz	0.2 MHz	0.5 MHz	1 MHz	2 MHz	5 MHz
10 MHz	20 MHz	50 MHz	0.1 GHz	0.2 GHz	0.5 GHz
1 GHz					

At this time, set the frequencies of the signal generator and MS610B/J setting at step 3 to the same frequency as the FREQ SPAN.

Frequency span = Signal generator output frequency = MS610B/J setting at step 3

6.4.4 Resolution bandwidth selectivity

(1) Specification

60 dB/3 dB ratio \leq 15:1

Data sheet: Table 6-7

(2) Setup

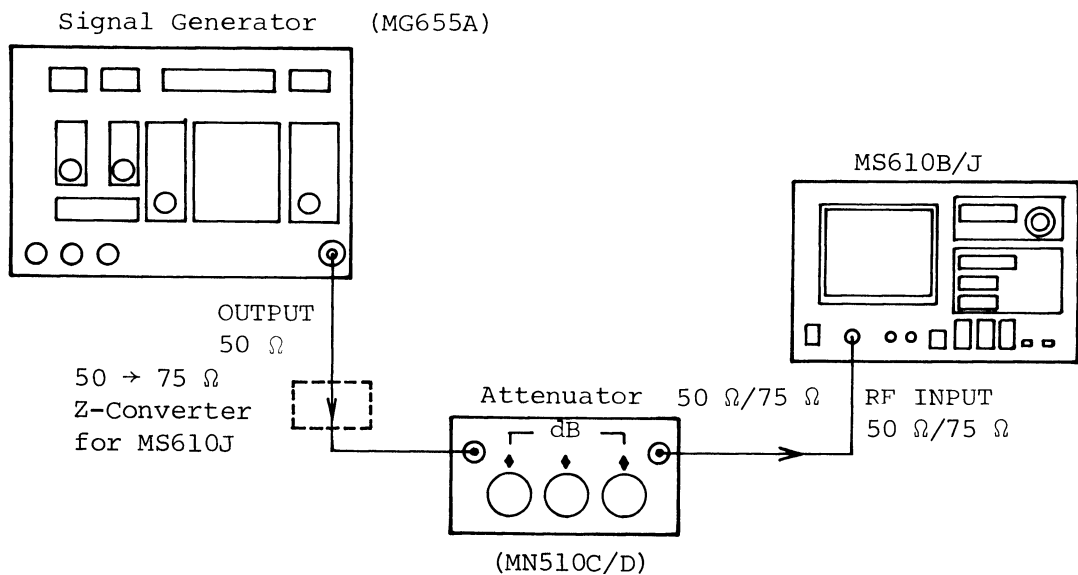

Fig. 6-5 Resolution Bandwidth Selectivity Test Setup

(3) Procedure

Step	Procedure
	(First, the 60 dB bandwidth is found in Steps 1 to 8.)
1	Set the MS610B/J as follows:
	CENTER FREQ 100 MHz
	FREQ SPAN ZERO SPAN
	REFERENCE LEVEL 0 dBm
	VERTICAL SCALE LOG 10 dB/div
	COUPLED TO SPAN ON (RBW = 30 kHz)
	INPUT ATTEN 10 dB

(Continued)

Step	Procedure
2	Set the attenuator to 60 dB.
3	Set the signal generator output as follows: Frequency 100 MHz Level approx. -10 dBm Set the receiving level trace to maximum by fine-adjusting the signal generator output frequency.
4	Fine-adjust the signal generator output level so that the trace of the receiving level coincides with the second horizontal scale line above the baseline.
5	Set the attenuator to 0 dB and check that the trace of the receiving level rises to the top horizontal scale line (REFERENCE LEVEL).
6	Lower the signal generator output frequency and read the frequency (f_L) at the point at which the trace of the receiving level has dropped by 60 dB to the second horizontal scale line above the base line.
7	Raise the signal generator output frequency and read the frequency (f_U) at the point at which the trace of the receiving level has passed the maximum value and has again dropped by 60 dB to the second horizontal scale line above the base line.

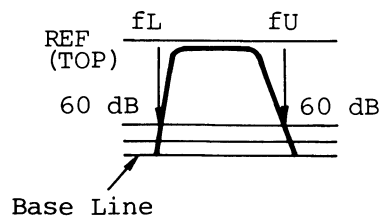

(Continued)

Step	Procedure
8	Find the 60 dB bandwidth as ($f_U - f_L$). (Next, the 3 dB bandwidth is found in Steps 9 to 16 as follows.)
9	Change the vertical scale of the MS610B/J to LOG 2 dB/div.
10	Set the attenuator to 3 dB.
11	Set the trace of the receiving level to maximum by fine-adjusting the signal generator output frequency.
12	Fine-adjust the signal generator output level so that the trace of the receiving level coincide with the one and half horizontal scale line under the top line.
13	Set the attenuator to 0 dB (3 dB reduction) and check that the trace of the receiving level rises to the top horizontal scale line (REFERENCE LEVEL).
14	Lower the signal generator output frequency and read the frequency (f_L') at the point at which the trace of the receiving level has dropped to the one and half horizontal scale line under the top line.
15	Raise the signal generator output frequency and read the frequency (f_U') at the point at which the trace of the receiving level has passed the maximum value and has again dropped to the one and half horizontal scale line under the top line.

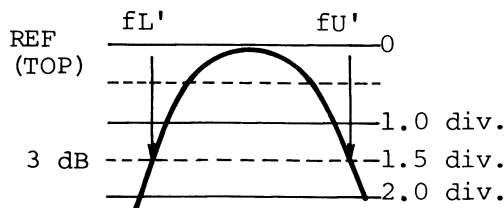

(Continued)

Step	Procedure
16	Find the 3 dB bandwidth as $(fU' - fL')$. (Next, 60 dB/3 dB ratio is found.)
17	Find the ratio of the 60 dB bandwidth to the 3 dB bandwidth $(fU - fL)/(fU' - fL')$. Confirm that 60 dB/3 dB ratio is less than 15:1. (Next, the ratio for other RBWs are found.)
18	Change the 30 kHz of RBW to another value of RBW (1 MHz to 1 kHz). Test the RBW as described in Steps 1 to 17. When the RBW is 300 kHz or 1 MHz, the measurement error becomes larger because of noise; set the VIDEO FILTER to 100 Hz, then start the measurement.

6.4.5 Frequency stability

(1) Specification

≤ 50 kHz/5 min. 1 hour after power-on for fixed frequency setting

Data sheet: Table 6-8

(2) Setup

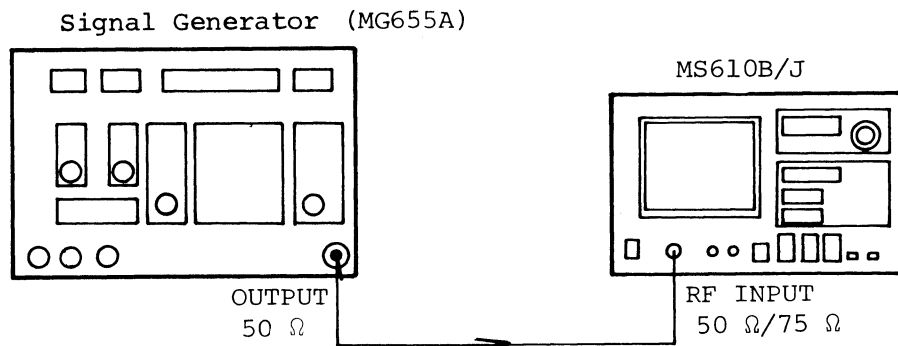

Fig. 6-6 Frequency Stability Test Setup

(3) Procedure

Step	Procedure
1	Set the signal generator as follows: Level 0 dBm Frequency 100 MHz
2	Connect the signal generator and MS610B/J as shown in the Fig. 6-6.
3	Before setting the POWER to ON, set the MS610B/J to POWER OFF for at least five hours. Set the MS610B/J to POWER ON. Start a stop watch to measure time, simultaneously.

(Continued)

Step	Procedure
4	Set the MS610B/J as follows: CENTER FREQ 100 MHz FREQ SPAN 100 kHz REF LEVEL 0 dBm COUPLED TO REF ON COUPLED TO SPAN ON
5	After one hour, turn the COARSE and FINE dials of the MS610B/J to adjust the 100 MHz spectrum trace to the center of the CRT.
6	Read the trace deviation from the center of the CRT after five minutes. Confirm that the trace deviation (frequency stability) is less than 50 kHz.

6.4.6 Residual FM

(1) Specification

≤ 2 kHzp-p at ≤ 0.1 s sweep time

Data sheet: Table 6-9

(2) Setup

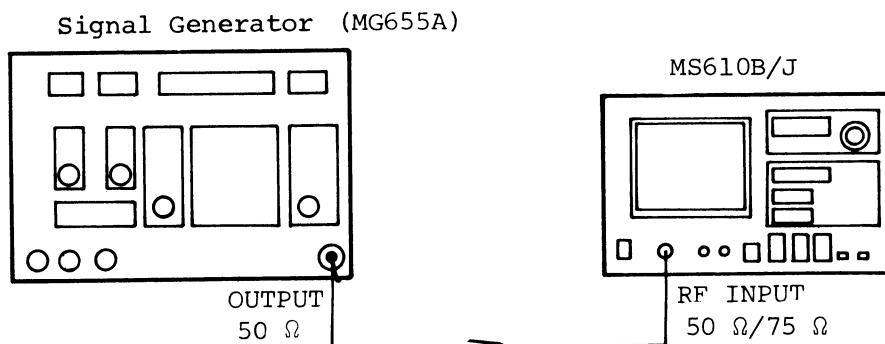

Fig. 6-7 Residual FM Test Setup

(3) Procedure

Step	Procedure
1	Set the signal generator as follows: Frequency 100 MHz Level 0 dBm
2	Set the MS610B/J as follows: CENTER FREQ 100 MHz REF LEVEL -4 dBm RBW 10 kHz FREQ SPAN 0.1 MHz SWEEP TIME 0.1 s COUPLED TO SPAN OFF
3	Connect the signal generator and the MS610B/J as shown in Fig. 6-7 and receive the 100 MHz signal as shown in Fig. 6-8. Read the number of vertical graticules for one horizontal graticule (10 kHz). Assume this to be A (Fig. 6-8).
4	Set the FREQ SPAN of the MS610B/J to 0 MHz. Read the number of graticules showing the signal peak to peak amplitude. Assume this to be B (Fig. 6-9).
5	Obtain the residual FM from the following equation. $\text{Residual FM} = \frac{10}{A} \times B \text{ (kHz)}$ Confirm that the residual FM is less than 2 kHzp-p at <u>≤</u> 0.1 s sweep time.

(Continued)

Step	Procedure
------	-----------

5
(cont.)

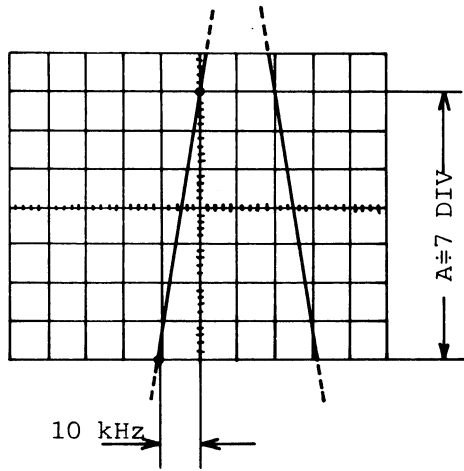

Fig. 6-8

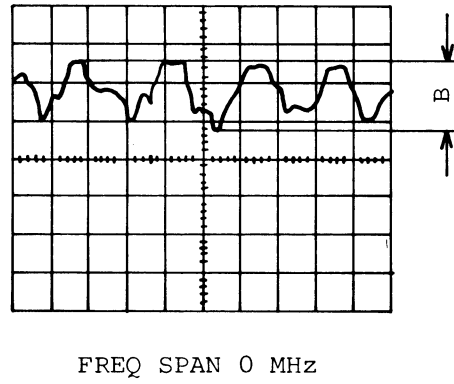

Fig. 6-9

6.4.7 Sideband noise

(1) Specification

≤ -70 dB (RBW 1 kHz, video filter 100 Hz,
20 kHz away from signal)

Data Sheet: Table 6-10

(2) Setup

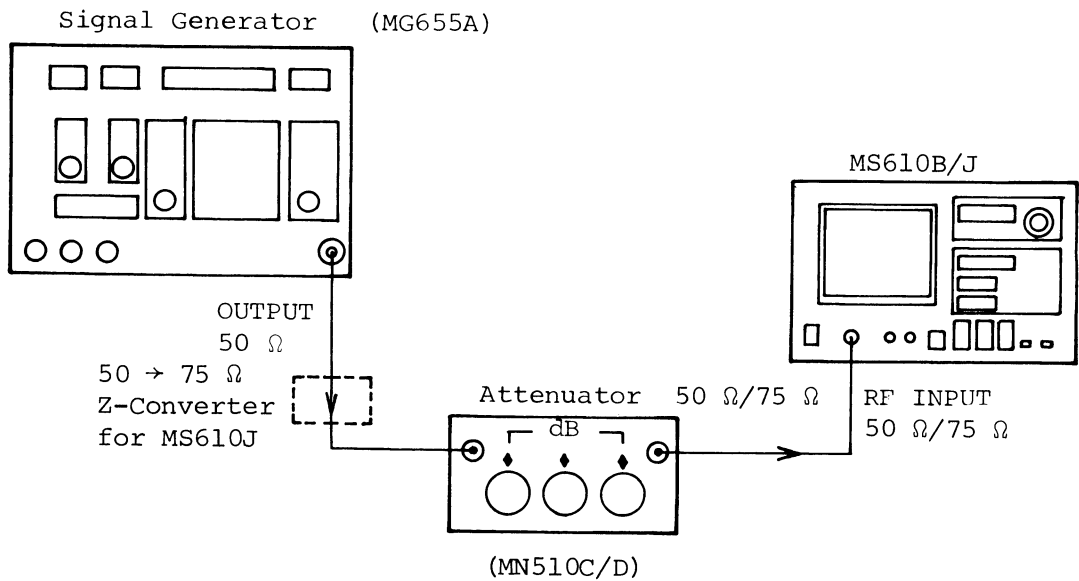

Fig. 6-10 Sideband Noise Test Setup

(3) Procedure

Step	Procedure
1	Set the MS610B/J as follows:
	CENTER FREQ 100 MHz
	FREQ SPAN 0.2 MHz
	REFERENCE LEVEL 0 dBm
	VERTICAL SCALE LOG 10 dB/div
	RBW 1 kHz

(Continued)

Step	Procedure
2	Set the attenuator to 0 dB. Set the signal generator output as follows:
	Frequency 100 MHz Level 0 dBm
3	Turn the COARSE and FINE dials to position the 100 MHz signal spectrum trace on the center of the CRT. Then, set FREQ SPAN to 0.1 MHz and turn the COARSE and FINE dials to position the trace on the center of the CRT again.
4	Set the attenuator to -30 dB.
5	Set the MS610B/J reference level to -30 dBm and position the 100 MHz signal spectrum trace peak on the center top horizontal scale line by fine-adjusting the signal generator output level.
6	Set the MS610B/J VIDEO FILTER to 100 Hz.
7	Set the attenuator to 0 dB, and measure the level at ± 20 kHz away from the center frequency. Confirm that it is below the center horizontal scale line (-70 dBm).

6.4.8 LOG scale linearity

(1) Specification

$\leq \pm 1$ dB/16 dB, $\leq \pm 1.5$ dB/72 dB

Data Sheet: Table 6-11

(2) Setup

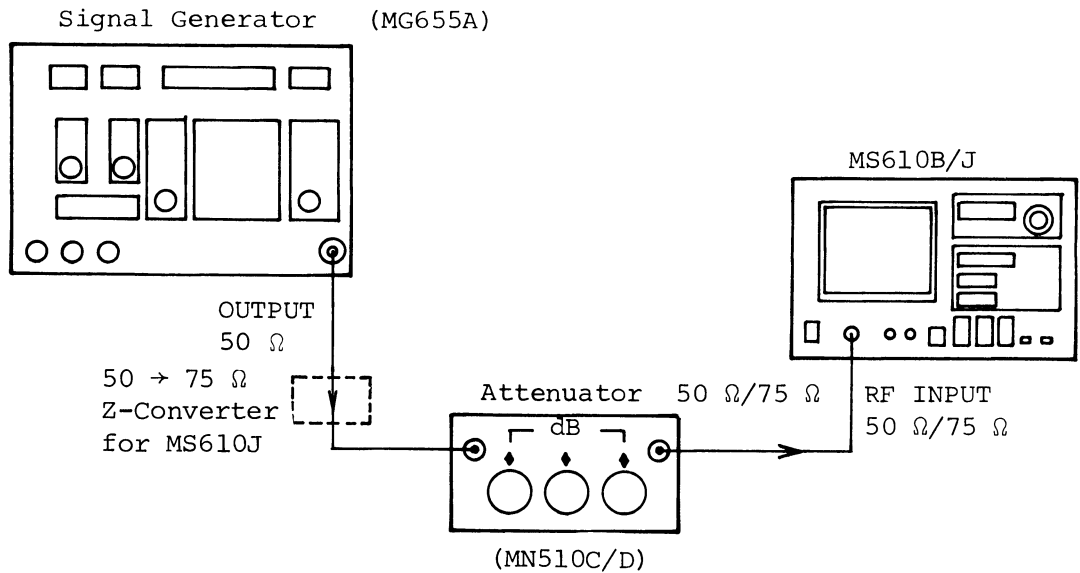

Fig. 6-11 LOG Scale Linearity Test Setup

(3) Procedure

Step	Procedure
1	Set the MS610B/J as follows:
	CENTER FREQ 100 MHz
	FREQ SPAN 0.1 MHz
	REFERENCE LEVEL 0 dBm
	VERTICAL SCALE 2 dB/div
	RBW 1 kHz
	VIDEO FILTER 100 Hz
	INPUT ATTEN 20 dB

(Continued)

Step	Procedure
2	Set the attenuator to 0 dB. Set the signal generator output as follows:
	Frequency 100 MHz Level approx. 0 dBm
3	Fine-adjust the signal generator output level so that the peak of the 100 MHz spectrum trace is on the horizontal top scale line.
4	Change the attenuation of the attenuator, so that the peak of the spectrum trace is on the Nth scale line (N = 1 up to 8) from the top horizontal scale line (No. 0), and then read the attenuator setting.
5	Calculate the accumulated error for each scale line No. from the attenuator setting (actual value) - attenuator nominal value (scale line No.). Confirm that the error is less than ± 1 dB/16 dB.
6	Change the MS610B/J setting as follows: VERTICAL SCALE LOG 10 dB/div
7	Set the attenuator to 0 dB, and check whether the peak of the 100 MHz spectrum trace coincides with the top horizontal scale line (REFERENCE LEVEL) (error within ± 1 dB).
8	Set the peak of the spectrum trace to the top horizontal scale line by fine-adjusting the signal generator output level.
9	Change the attenuation of the attenuator so that the peak of the spectrum trace is on the Nth scale line (N=1 up to 7) from the top horizontal scale line (No. 0), and then read the attenuator setting.

(Continued)

Step	Procedure
10	Change the attenuation of the attenuator and adjust the spectrum peak on the 1/5 graticule line below scale line No. 7 (72 dB).
11	Read the attenuation.
12	Calculate the accumulated error as described in Step 5. Confirm that the error is less than ± 1.5 dB/72 dB.

6.4.9 Reference level accuracy

(1) Specification

$\leq \pm 1.5$ dB (after calibration using CAL OUTPUT)

Data Sheet: Table 6-12

(2) Setup

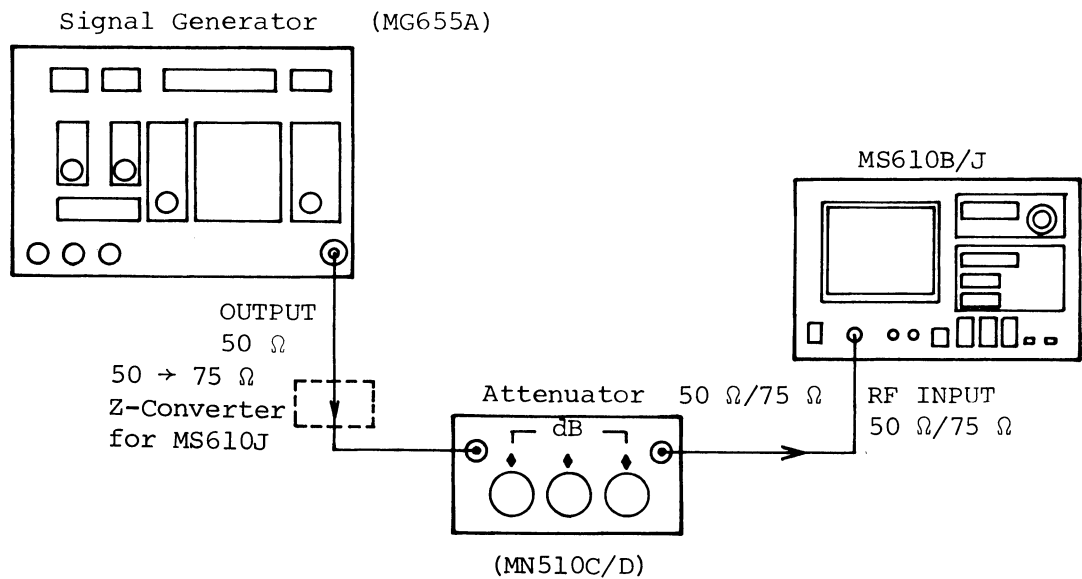

Fig. 6-12 Reference Level Accuracy Test Setup

(3) Procedure

Step	Procedure												
1	Set the MS610B/J as follows: <table><tr><td>CENTER FREQ</td><td>50 MHz</td></tr><tr><td>FREQ SPAN</td><td>1 MHz</td></tr><tr><td>RBW</td><td>3 kHz</td></tr><tr><td>REFERENCE LEVEL</td><td>-30 dBm</td></tr><tr><td>VERTICAL SCALE</td><td>LOG 2 dB/div</td></tr><tr><td>COUPLED TO REF</td><td>ON</td></tr></table>	CENTER FREQ	50 MHz	FREQ SPAN	1 MHz	RBW	3 kHz	REFERENCE LEVEL	-30 dBm	VERTICAL SCALE	LOG 2 dB/div	COUPLED TO REF	ON
CENTER FREQ	50 MHz												
FREQ SPAN	1 MHz												
RBW	3 kHz												
REFERENCE LEVEL	-30 dBm												
VERTICAL SCALE	LOG 2 dB/div												
COUPLED TO REF	ON												
2	Set the signal generator as follows: <table><tr><td>Frequency</td><td>50 MHz</td></tr><tr><td>Level</td><td>+10 dBm</td></tr></table>	Frequency	50 MHz	Level	+10 dBm								
Frequency	50 MHz												
Level	+10 dBm												
3	Set the attenuator to 40 dB.												
4	Fine-adjust the signal generator output level so that the peak of the 50 MHz spectrum trace is on the top horizontal scale line. (initial setting)												
5	Change the REFERENCE LEVEL setting and the attenuator settings by the same amount simultaneously. Find the reference level error from the difference between the attenuator nominal value (A) and actual value (B), when the peak of the spectrum trace is set to the top horizontal scale line by changing the attenuator setting. (See Table 6-13 Data Sheet) Confirm that the error is less than ± 1.5 dB.												

6.4.10 Frequency response

(1) Specification

$\leq \pm 1.5$ dB (100 kHz to 1.5 GHz), $\leq +2/-3$ dB (1.5 to 2 GHz) at input attenuator ≥ 10 dB

Data sheet: Table 6-13

(2) Setup

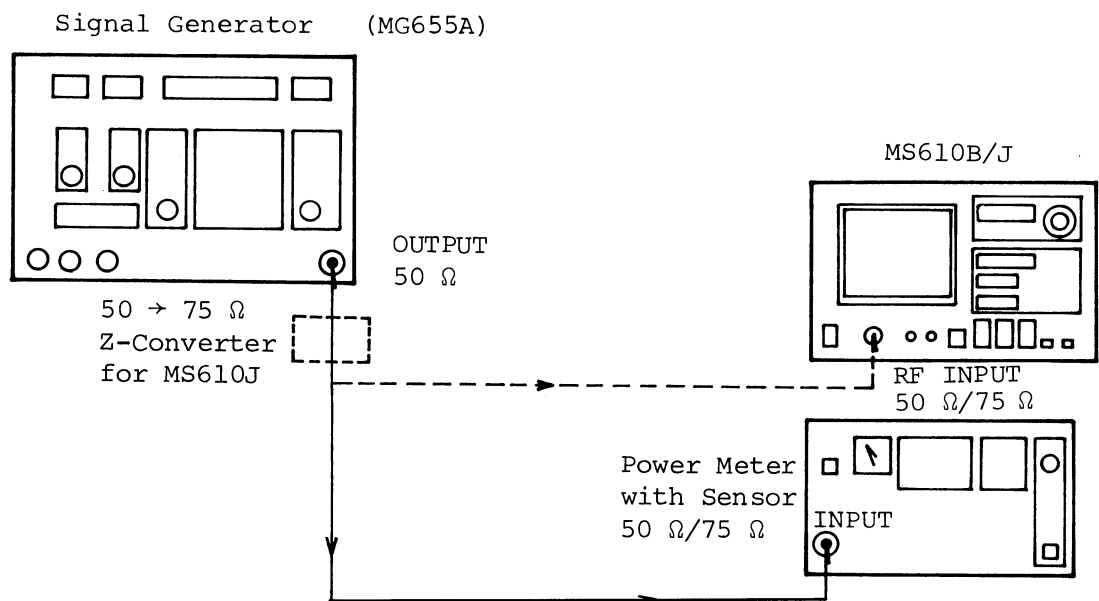

Fig. 6-13 Frequency Response Test Setup

(3) Procedure

Step	Procedure
1	Set the MS610B/J as follows: CENTER FREQ 10 MHz FREQ SPAN 1 MHz REFERENCE LEVEL 0 dBm SCALE LOG 2 dB/div COUPLED TO SPAN ON COUPLED TO REF ON
2	Set the signal generator output frequency to the CENTER FREQ frequency of the MS610B/J.
3	Connect the signal generator output to the power meter and adjust the signal generator output level to -8 dBm.
4	Input the signal generator output to the MS610B/J.
5	Turn the GAIN ADJ volume knob of the MS610B/J and adjust the 10 MHz signal spectrum to the center horizontal line as shown in Fig. 6-14. (10 MHz signal becomes reference level.)
6	Set the signal generator output frequency and the CENTER FREQ of the MS610B/J to 100 kHz, 1 MHz, 10 MHz, 100 MHz, 1000 MHz, 1.5 GHz, and 2 GHz, respectively, and perform steps 1 to 4. Read the deviation between the spectrum and the center horizontal line. Confirm that the deviation (frequency response) satisfies the specification.

(Continued)

Step	Procedure
------	-----------

6
(cont.)

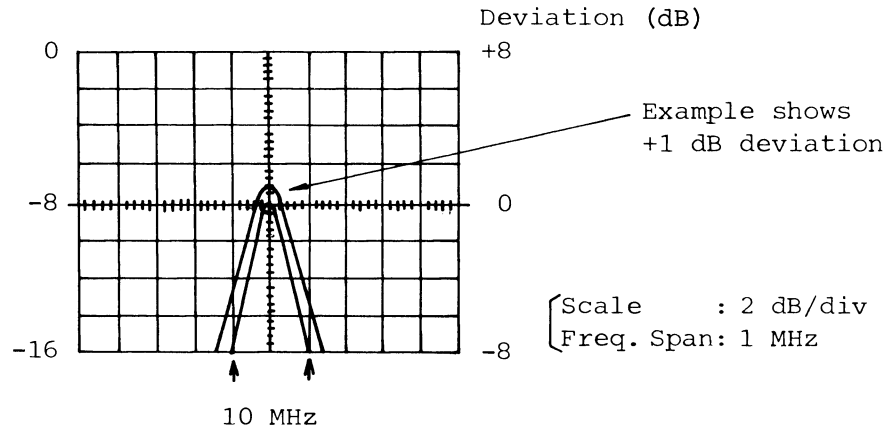

Fig. 6-14

6.4.11 Average noise level

(1) Specification

≤ -115 dBm (MS610B) / ≤ -107 dBm (MS610J), at RBW
1 kHz, video filter 100 Hz, and frequency ≥ 1 MHz

Data sheet: Table 6-14

(2) Setup

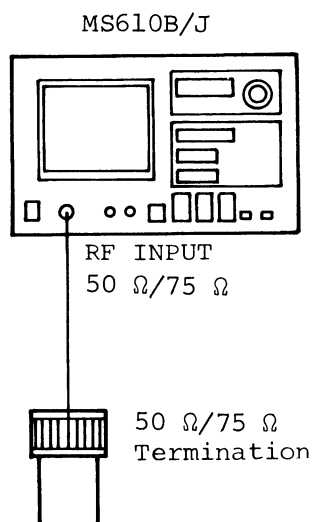

Fig. 6-15 Average Noise Level Test Setup

(3) Procedure

Step	Procedure
1	Set the MS610B/J as follows: CENTER FREQ 100 MHz FREQ SPAN 0.1 MHz REFERENCE LEVEL -50 dBm SCALE LOG 10 dB/div VIDEO FILTER 100 Hz COUPLED TO SPAN ON (RBW = 1 kHz) COUPLED TO REF ON

(Continued)

Step	Procedure
2	Read the average noise level on the CRT screen. Confirm that it is less than -115 dBm for MS610B or -107 dBm for MS610J.
3	Change the center frequency to 1 MHz and 2 GHz and repeat Step 2.

6.4.12 2nd and 3rd harmonics distortion

(1) Specification

≤ 70 dB (100 kHz to 1000 MHz)/ ≤ 80 dB (5 to
800 MHz) at input level -30 dBm,
input attenuator 0 dB

Data sheet: Table 6-15

(2) Setup

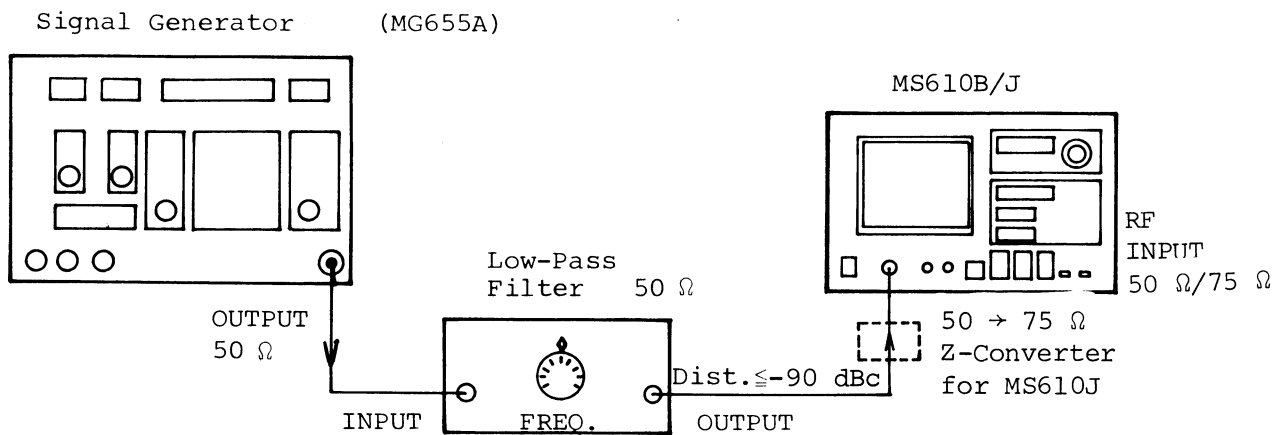

Fig. 6-16 2nd and 3rd Harmonic Distortion Test Setup

(3) Procedure

Step	Procedure
1	Set the signal generator as follows: LEVEL Approx. -30 dBm FREQUENCY 100 kHz (distortion test frequency)
2	Set the cut off frequency of the low pass filter so that the second and third harmonics of the test frequency signal are attenuated to 90 dB or more.
3	Set the MS610B/J as follows: CENTER FREQ 100 kHz (distortion test frequency) FREQ SPAN 500 kHz (distortion test frequency x 5) INPUT ATTEN 0 dB REF LEVEL -30 dBm
4	Receive the test frequency signal from the signal generator and adjust the signal generator output level so that the fundamental component of the signal is on the top line of the CRT.
5	Increase the signal generator output level by 10 dB. (-20 dBm)
6	Receive the second and third harmonics, and read the level difference between the fundamental and higher harmonics signals. At this time, the second line from the base line becomes 80 dB for the level difference of the second higher harmonic. For the level difference of the third higher harmonic, the third line from the base line becomes 80 dB (Fig. 5-17).

(Continued)

Step	Procedure
7	Repeat Steps 1 to 6 for 1 MHz, 5 MHz, 10 MHz, 100 MHz, 800 MHz, and 1 GHz distortion test frequencies. Confirm that the 2nd and 3rd harmonics distortion is less than 80 dB for 5 to 800 MHz and 70 dB for 100 kHz to 1000 MHz.

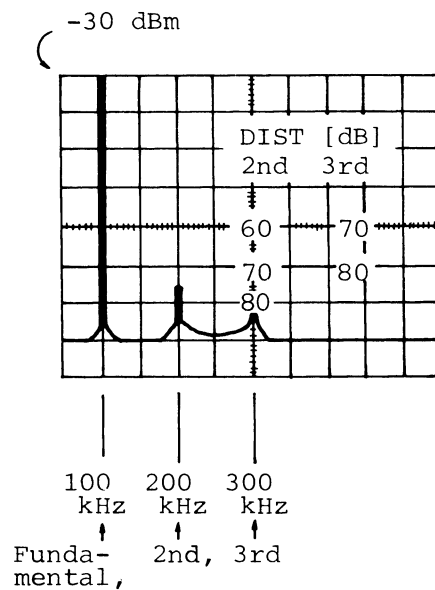

Fig. 6-17 Distortion Level

6.4.13 Residual spurious response

(1) Specification

≤ -100 dBm, for $50\ \Omega/75\ \Omega$ input termination, at input attenuator 0 dB, and frequency ≥ 100 kHz

Data sheet: Table 6-16

(2) Setup

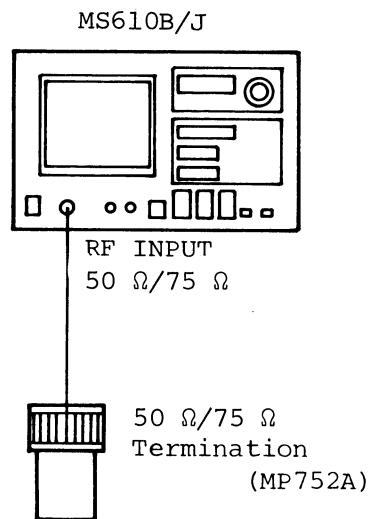

Fig. 6-18 Residual Spurious Response Test Setup

(3) Procedure

Step	Procedure
1	Set the MS610B/J as follows: CENTER FREQ 3 MHz FREQ SPAN 5 MHz REFERENCE LEVEL -50 dBm VERTICAL SCALE LOG 10 dB/div COUPLED TO REF ON COUPLED TO SPAN ON VIDEO FILTER 100 Hz

(Continued)

Step	Procedure
2	Observe the spectrum trace after one or more complete sweeps have ended and check to ensure there is no spectrum trace (residual response) of -100 dBm or more.
3	Change the center frequency of the MS610B/J to "present frequency +5 MHz".
4	Repeat Steps 2 and 3 until the upper frequency limit (2 GHz) is reached. Confirm that the residual response is less than -100 dBm.

6.4.14 Resolution bandwidth gain variation

(1) Specification

$$\leq \pm 1 \text{ dB}$$

Data sheet: Table 6-17

(2) Setup

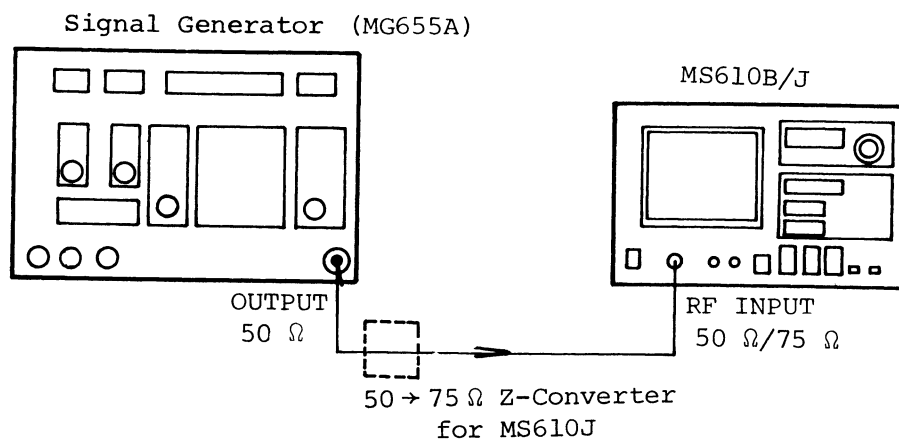

Fig. 6-19 Resolution Bandwidth Gain Variation Test Setup

(3) Procedure

Step	Procedure
1	Set the MS610B/J as follows: CENTER FREQ 100 MHz FREQ SPAN 0.1 MHz REF LEVEL 0 dBm SCALE 2 dB/div RBW 30 kHz
2	Set the signal generator as follows: Level -8 dBm Frequency 100 MHz
3	Turn the COARSE and FINE dials of the MS610B/J and adjust the 100 MHz signal trace to the center of the CRT.
4	Turn the GAIN ADJ volume knob and adjust the signal peak to the vertical center line of the CRT.
5	Vary the RBW from 1 kHz to 1 MHz and read the level deviation from the 30 kHz RBW reference level. Confirm that it is less than ± 1 dB.

6.4.15 RF input impedance (terminal)

(1) Specification

50 Ω , VSWR ≤ 1.5 at input attenuator ≥ 10 dB,
N type connector (MS610B),
75 Ω , VSWR ≤ 1.5 at input attenuator ≥ 10 dB,
NC type connector (MS610J)

Data sheet: Table 6-18

(2) Setup

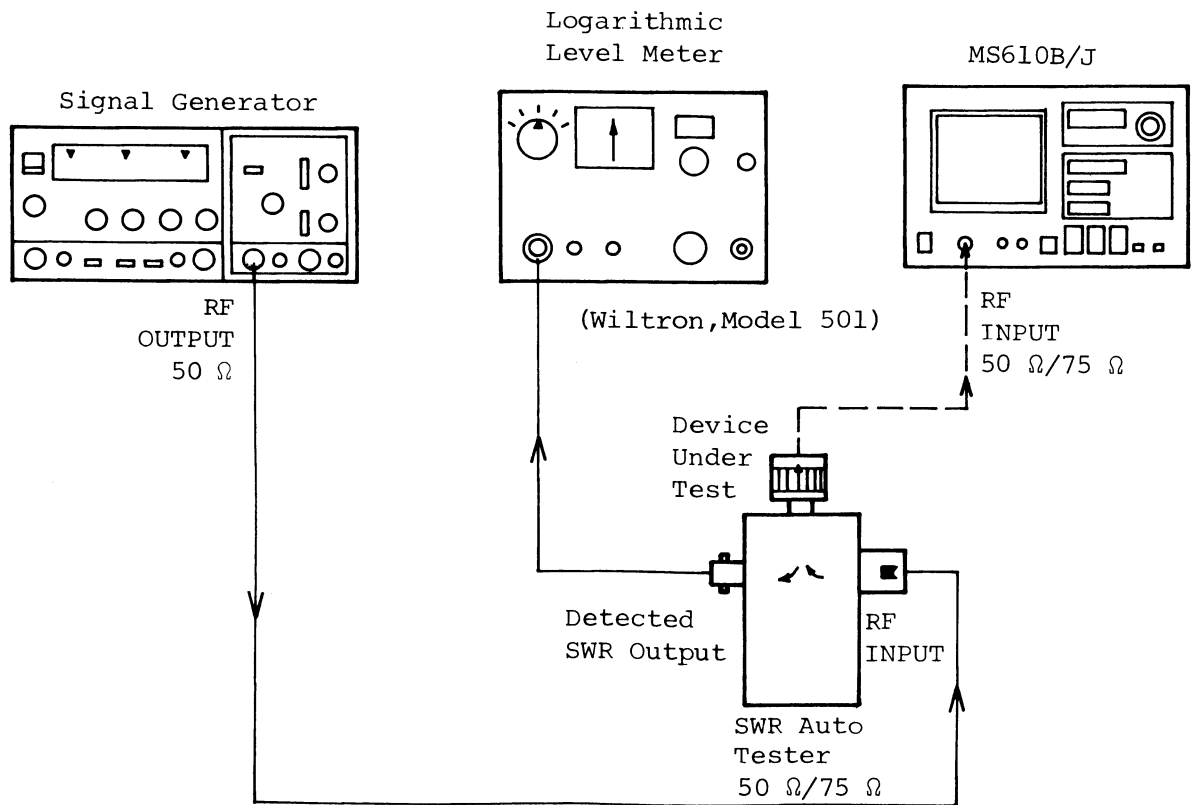

Fig. 6-20 RF Input Impedance (Terminal) Test Setup

(3) Procedure

Step	Procedure
1	Set the MS610B/J as follows: COUPLED TO REF OFF INPUT ATTEN 10 dB
2	Set up as shown in Fig. 6-20.
3	Set the signal generator as follows: Frequency 2 GHz Level 0 dBm
4	Set the logarithmic level meter (Wiltron, Model 501) as follows: Sensitivity 2 dB/major div Meter ON
5	Disconnect the DEVICE UNDER TEST port of the VSWR auto tester from the RF INPUT of the MS610B/J.
6	Set the offset control of the level meter to 0 dB.
7	Adjust the zero dB set control of the level meter so that the meter indicates 0 dB (center).
8	Connect the DEVICE UNDER TEST port of the VSWR auto tester directly to the RF INPUT of the MS610B/J.
9	Adjust the offset control of the level meter so that the level meter indicates 0 dB (center). Read the offset value, which is the return loss value.

(Continued)

Step	Procedure
10	Vary the input attenuation of the MS610B/J to 20, 30, 40, and 50 dB and read the corresponding offset values.

Note:

The specified attenuation may not be set by pressing the INPUT ATTEN key; change REF LEVEL, then set INPUT ATTEN. (See Fig. 3-4 in Section 3.)

- 11 Change the signal generator output frequency to 1.5 GHz, 1 GHz, and 100 MHz. At each frequency, follow steps 5 to 10.

Note:

The relationship between return loss and VSWR is shown in Table 6-3.

Table 6-3 Relationship Between Return Loss and VSWR

Return Loss (dB)	VSWR
10	1.93
11	1.78
12	1.67
13	1.58
14	1.50
15	1.43
16	1.38
17	1.33
18	1.29
19	1.25
20	1.22
25	1.12
30	1.07

Formula:

$$VSWR = \frac{10^{\frac{x}{20}} + 1}{10^{\frac{x}{20}} - 1}$$

where x : return loss (dB)

6.4.16 Power consumption

(1) Specification

** Vac $\pm 10\%$, 50/60 Hz, ≤ 85 VA

Data sheet: Table 6-19

(2) Setup

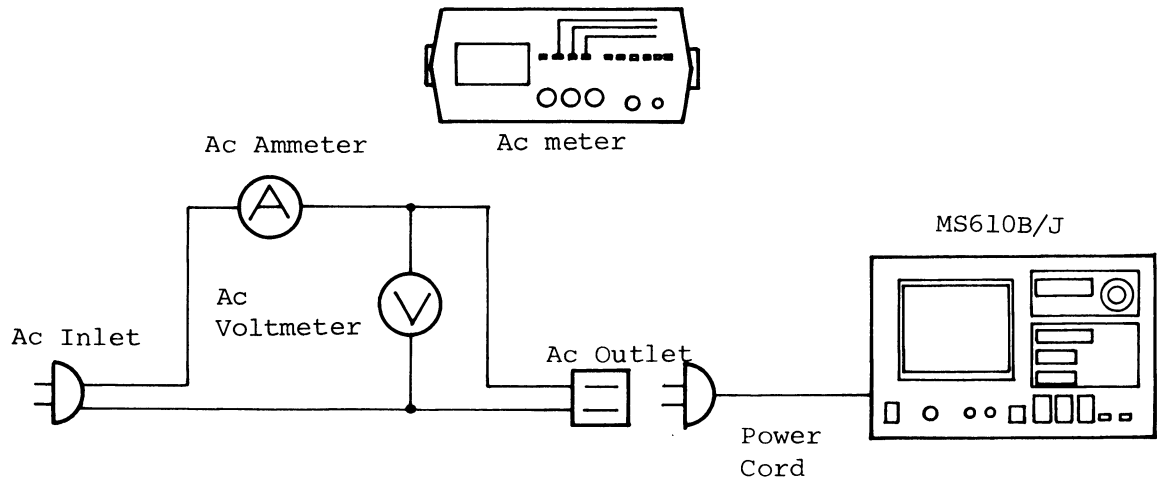

Fig. 6-21 Power Consumption Test Setup

(3) Procedure

Step	Procedure
1	Connect the measuring ac inlet to the commercial ac voltage supply inlet through the ac ammeter and ac voltmeter, as shown in Fig. 6-21.
2	Connect the MS610B/J accessory power supply cord to the ac outlet.
3	Set the MS610B/J power switch to ON. Read the value of the ac voltmeter and the ac ammeter. The power consumption value is calculated from the following formula: $VA = (\text{reading of the ac voltmeter}) \times (\text{reading of ac ammeter})$

6.4.17 Data sheets

Table 6-4 CAL Output Test Data Sheet

Test Item	Min.	Actual	Max.
Output level (dBm)	-30.5	\leq _____ \leq	-29.5
Frequency (MHz)	49.85	\leq _____ \leq	50.15

Table 6-5 Frequency Display Accuracy Test Data Sheet

Measurement Conditions	Frequency Reading (MHz)		
Center Frequency (MHz)	Min.	Actual	Max.
1000	990	\leq _____ \leq	1010
100	90	\leq _____ \leq	110
10	0	\leq _____ \leq	20
2000	1990	\leq _____ \leq	2010

Table 6-6 Frequency Span Accuracy Test Data Sheet

Frequency Span	Min.	Actual	Max.
2 GHz	1900 MHz	< _____ <	2100 MHz
1 GHz	950 MHz	< _____ <	1050 MHz
0.5 GHz	475 MHz	< _____ <	525 MHz
0.2 GHz	190 MHz	< _____ <	210 MHz
0.1 GHz	95 MHz	< _____ <	105 MHz
50 MHz	47.5 MHz	< _____ <	52.5 MHz
20 MHz	19 MHz	< _____ <	21 MHz
10 MHz	9.5 MHz	< _____ <	10.5 MHz
5 MHz	4.75 MHz	< _____ <	5.25 MHz
2 MHz	1900 kHz	< _____ <	2100 kHz
1 MHz	950 kHz	< _____ <	1050 kHz
0.5 MHz	475 kHz	< _____ <	525 kHz
0.2 MHz	190 kHz	< _____ <	210 kHz
0.1 MHz	95 kHz	< _____ <	105 kHz

(Specification: $\leq \pm 5\%$)

Table 6-7 Resolution Bandwidth Selectivity Test Data Sheet

RBW	60 dB Bandwidth	3 dB Bandwidth	Selectivity (60 dB BW/3 dB BW)
1 MHz	_____	_____	_____ ≤ 15
300 kHz	_____	_____	_____ ≤ 15
100 kHz	_____	_____	_____ ≤ 15
30 kHz	_____	_____	_____ ≤ 15
10 kHz	_____	_____	_____ ≤ 15
3 kHz	_____	_____	_____ ≤ 15
1 kHz	_____	_____	_____ ≤ 15

Table 6-8 Frequency Stability Test Data Sheet

Frequency Stability: _____ kHz/5 min \leq 50 kHz/5 min.

Table 6-9 Residual FM Test Data Sheet

Residual FM: _____ kHz p-p/0.1 s \leq 2 kHz p-p/0.1 s

Table 6-10 Sideband Noise Test Data Sheet

Sideband Noise: _____ dB \leq -70 dB

Table 6-11 LOG scale Linearity Test Data Sheet

1. 2 dB/div

Scale Line No.	Input Attenuation Setting (dB)		Accumulated Error (dB)
	Nominal Value	Actual Value	
0	0	0	
1	2		-1 ≤ _____ ≤ +1
2	4		-1 ≤ _____ ≤ +1
3	6		-1 ≤ _____ ≤ +1
4	8		-1 ≤ _____ ≤ +1
5	10		-1 ≤ _____ ≤ +1
6	12		-1 ≤ _____ ≤ +1
7	14		-1 ≤ _____ ≤ +1
8	16		-1 ≤ _____ ≤ +1

Accumulated Error =
 (Actual value for scale line N) - (Nominal value for horizontal scale line N)

2. 10 dB/div

Scale Line No.	Input Attenuation Setting (dB)		Accumulated Error (dB)
	Nominal Value	Actual Value	
0	0	0	
1	10		-1.5 ≤ _____ ≤ +1.5
2	20		-1.5 ≤ _____ ≤ +1.5
3	30		-1.5 ≤ _____ ≤ +1.5
4	40		-1.5 ≤ _____ ≤ +1.5
5	50		-1.5 ≤ _____ ≤ +1.5
6	60		-1.5 ≤ _____ ≤ +1.5
7	70		-1.5 ≤ _____ ≤ +1.5
7.2	72		-1.5 ≤ _____ ≤ +1.5

Table 6-12 Reference Level Accuracy Test Data Sheet

REFERENCE LEVEL (dBm)	Attenuation Nominal Value A (dB)	Attenuation Actual Value B (dB)	Reference Level Error B-A (dB)
+10	0	_____	_____
0	10	_____	_____
-10	20	_____	_____
-20	30	_____	_____
-30	40	_____	_____
-40	50	_____	_____
-50	60	_____	_____
<hr/>			
-31	41	_____	_____
-32	42	_____	_____
-33	43	_____	_____
-34	44	_____	_____
-35	45	_____	_____
-36	46	_____	_____
-37	47	_____	_____
-38	48	_____	_____
-39	49	_____	_____
<hr/>			
(Specification: $\leq \pm 1.5$ dB)			

Table 6-13 Frequency Response Test Data Sheet

Measurement Frequency	Actual Value (dB)	Specification (dB)
100 kHz	_____	± 1.5
1 MHz	_____	± 1.5
10 MHz	<u>0 (Reference)</u>	
100 MHz	_____	± 1.5
1 GHz	_____	± 1.5
1.5 GHz	_____	± 1.5
2 GHz	_____	+2, -3

Table 6-14 Average Noise Level Test Data Sheet

Center Frequency	Actual Value	Specifications (dBm)
1 MHz	_____	≤ -115 (MS610B), -107 (MS610J)
100 MHz	_____	≤ -115 (MS610B), -107 (MS610J)
2 GHz	_____	≤ -115 (MS610B), -107 (MS610J)

Table 6-15 2nd and 3rd Harmonic Distortion Test Data Sheet

Measurement Frequency	2nd Harmonic Distortion	3rd Harmonic Distortion
100 kHz	_____ ≤ -70 dB	_____ ≤ -70 dB
1 MHz	_____ ≤ -70 dB	_____ ≤ -70 dB
5 MHz	_____ ≤ -80 dB	_____ ≤ -80 dB
10 MHz	_____ ≤ -80 dB	_____ ≤ -80 dB
100 MHz	_____ ≤ -80 dB	_____ ≤ -80 dB
800 MHz	_____ ≤ -80 dB	
1 GHz	_____ ≤ -70 dB	

Table 6-16 Residual Spurious Response Test Data Sheet

Measurement Frequency	Actual Value	Specification
_____ MHz	_____ dBm	≤ -100 dBm

Table 6-17 Resolution Bandwidth Gain Variation Test Data Sheet

RBW	Deviation (dB)
1 kHz	$-1 \leq \underline{\hspace{1cm}} \leq +1$
3 kHz	$-1 \leq \underline{\hspace{1cm}} \leq +1$
10 kHz	$-1 \leq \underline{\hspace{1cm}} \leq +1$
30 kHz	<u>0</u> (Reference Level)
100 kHz	$-1 \leq \underline{\hspace{1cm}} \leq +1$
300 kHz	$-1 \leq \underline{\hspace{1cm}} \leq +1$
1 MHz	$-1 \leq \underline{\hspace{1cm}} \leq +1$

Table 6-18 RF Input Impedance (Terminal) Test Data Sheet

Input Attenuation Setting (dB)	VSWR			
	100 MHz	1 GHz	1.5 GHz	2 GHz
10	_____	_____	_____	_____
20	_____	_____	_____	_____
30	_____	_____	_____	_____
40	_____	_____	_____	_____
50	_____	_____	_____	_____

(Specification: VSWR \leq 1.5)

Table 6-19 Power Consumption Test Data Sheet

VA : _____ VA \leq 85 VA (AC _____ V)

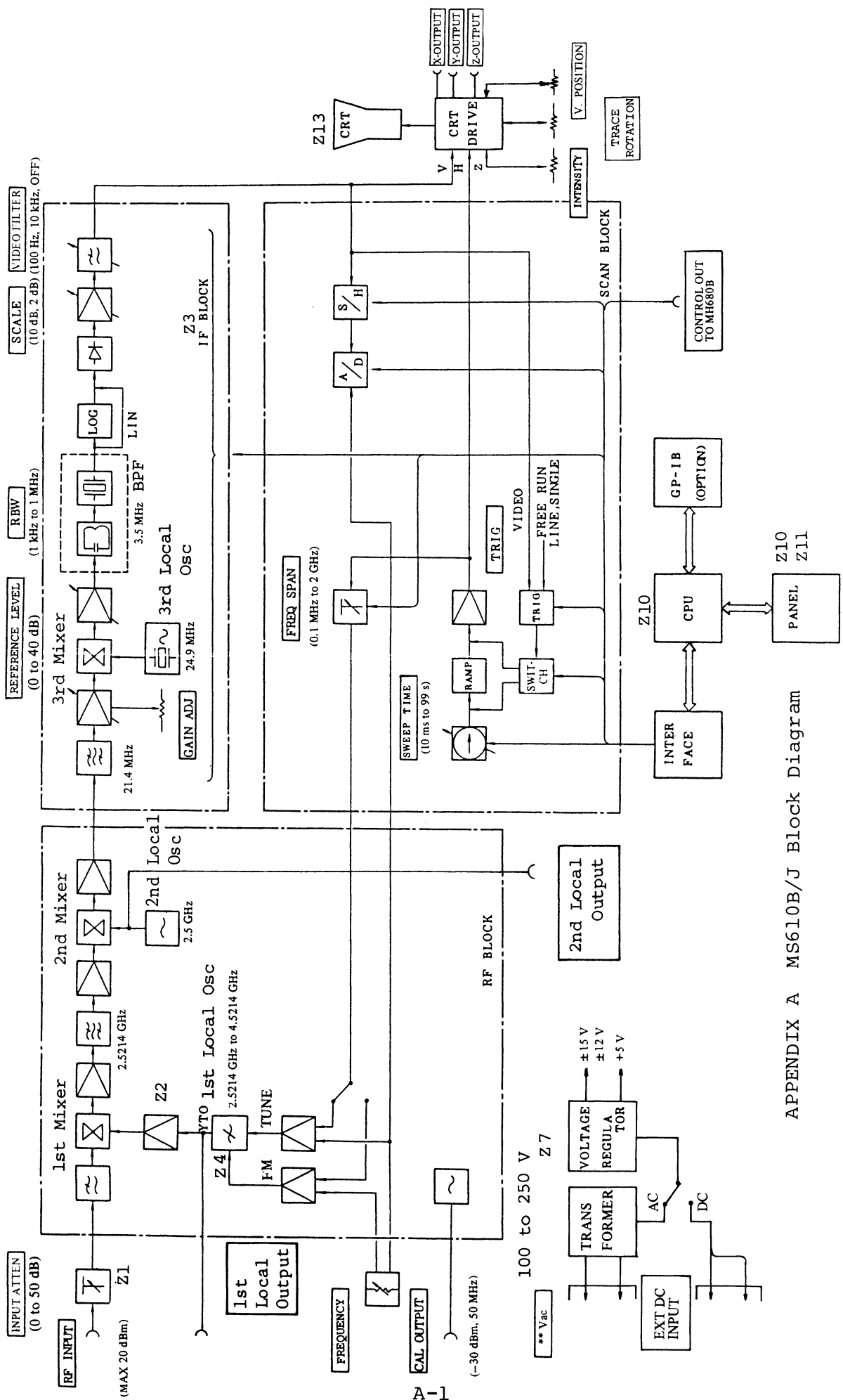

A-1

APPENDIX A MS610B/J Block Diagram

OPERATION MANUAL
SPECTRUM ANALYZER
MS610B/J GP-IB INTERFACE
(OPTION 01)

TABLE OF CONTENTS

		Page
SECTION 1	GENERAL	1-1
SECTION 2	FUNCTIONS	
2.1	GP-IB Interface Functions	2-1
2.2	Device Messages	2-2
SECTION 3	GP-IB ADDRESS	
3.1	Setting GP-IB Address	3-1
SECTION 4	DEVICE MESSAGES	
4.1	Outline of Device Messages	4-1
4.2	Control Message Formats	4-2
4.2.1	Format 1	4-2
4.2.2	Format 2	4-3
4.2.3	Format 3	4-4
4.2.4	Format 4	4-5
4.3	Data Request Message Format	4-6
4.4	Details of Device Messages	4-7
4.4.1	FDn (FDR) - CENTER FREQ/START FREQ	4-7
4.4.2	FQf (FQR) - FREQUENCY	4-7
4.4.3	RMn (RMR) - REF/MARKER	4-8
4.4.4	RLℓ (RLR) - REFERENCE LEVEL	4-9
4.4.5	* (MLR) - MARKER LEVEL	4-9
4.4.6	SAn (SAR) - SPAN/ATTEN	4-9

TABLE OF CONTENTS (Cont'd)

	Page
4.4.7	SPm (SPR) - FREQ SPAN 4-10
4.4.8	ATm (ATR) - INPUT ATTEN 4-10
4.4.9	RSn (RSR) - RBW/SWEEP T 4-11
4.4.10	RBm (RBR) - RBW 4-11
4.4.11	STm (STR) - SWEEP TIME 4-12
4.4.12	CSn (CSR) - COUPLED TO SPAN 4-12
4.4.13	CRn (CRR) - COUPLED TO REF 4-13
4.4.14	VFm (VFR) - VIDEO FILTER 4-13
4.4.15	SC (SCR) - SCALE 4-14
4.4.16	TGm (TGR) - TRIG 4-14
4.4.17	SS (*) - START (single) 4-14
4.4.18	LUm (LUR) - LEVEL UNIT 4-15
4.4.19	* (UCR) - DISPLAY UNCAL 4-15
4.4.20	MP P1,P2(*) - MARKER POINT 4-15
4.4.21	DC (*) - DEVICE CLEAR 4-16

SECTION 5 APPLICATION PROGRAM

5.1	Level measurement 5-1
5.2	Harmonic Spurious Signal Measurement 5-2
5.3	Frequency Characteristic Measurement (CRT Display Transfer to Packet III CRT) ... 5-3

SECTION 1

GENERAL

The MS610B/J spectrum analyzer can be controlled externally through a general purpose interface bus (GP-IB option OPT-01).

The GP-IB is a standardized interface bus for measurement applications, of which there are two models: one conforming to IEEE-488 standards (Institute of Electrical and Electronics Engineers) and one conforming to IEC-625 (International Electrotechnical Commission). The MS610B/J GP-IB conforms to IEEE-488 standards. All functions except the power switch, gain adjustment, intensity, zero adjustment, and frequency fine tuning can be controlled by an external computer. This remote capability makes it easier to carry out production automation plans and to reduce the time spent on system adjustment and inspection.

Notes

1. Please contact an ANRITSU for the publication titled "GP-IB Basic Guide".
 2. For details on MS610B/J functions, refer to "MS610B/J Spectrum Analyzer OPERATION Manual".
-

SECTION 2

FUNCTIONS

2.1 GP-IB Interface Functions

The interface functions of the MS610B/J spectrum analyzer are listed below in Table 2-1.

Table 2-1

Function	
SH1	Source handshake function provided
AH1	Accept handshake function provided
T8	Basic talker function provided Serial polling function not provided Talker only mode not provided Talker clear function by MLA provided
L4	Basic listener function provided Listen only mode not provided Listener clear function by MTA provided
SR0	Serial polling function not provided
RL1	All remote and local functions provided
PP0	Parallel polling function not provided
DC1	All device clear function provided
DT0	Device trigger function not provided
C0	Controller function not provided

2.2 Device Messages

The MS610B/J device messages are listed below in Table 2-2.

Table 2-2

Function	Control Message	Data request message
START/CENTER FREQ	FDn n: 0=CENTER, 1=START	FDR
FREQUENCY	FQf f: 0 to 2020 (MHz)	FQR
REF/MARKER	RMn n: 0=REF, 1=MARKER	RMR
REFERENCE LEVEL	RLℓ ℓ: -60.0 to +20.0 (dBm)	RLR
MARKER LEVEL	*	MLR
SPAN/ATTEN	SAn n: 0=SPAN, 1=ATTEN	SAR
FREQ SPAN	SPm m: 0=0Hz, 1=100kHz, 2=200kHz, 3=500kHz, 4=1MHz, 5=2MHz, 6=5MHz, 7=10MHz, 8=20MHz, 9=50MHz, 10=100MHz, 11=200MHz, 12=500MHz, 13=1GHz, 14=2GHz	SPR
INPUT ATTEN	ATm m: 0=0dB, 1=10dB, 2=20dB, 3=30dB, 4=40dB, 5=50dB	ATR
RBW/SWEEP T	RSn n: 0=RBW, 1=SWEEP T	RSR
RBW	RBm m: 0=1kHz, 1=3kHz, 2=9kHz, 3=10kHz, 4=30kHz, 5=100kHz, 6=120kHz, 7=300kHz, 8=1MHz	RBR
SWEEP TIME	STm m: 0=10ms, 1=20ms, 2=50ms, 3=100ms, 4=200ms, 5=500ms, 6=1s, 7=2s, 8=5s, 9=10s, 10=20s, 11=30s, 12=40s, 13=50s, 14=60s, 15=70s, 16=99s	STR

Table 2-2 (Cont.)

Function	Control Message	Data request message
COUPLED TO SPAN	CSn n: 0=OFF, 1=ON	CSR
COUPLED TO REF	CRn n: 0=OFF, 1=ON	CRR
VIDEO FILTER	VFm m: 0=OFF, 1=10kHz, 2=100Hz	VFR
SCALE	SCm m: 0=10dB/div, 1=2dB/div 2=LINEAR, 3=(QP) 5dB/	SCR
TRIG	TGm m: 0=FREE RUN, 1=LINE 2=VIDEO, 3=SINGLE	TGR
START (SINGLE)	SS	*
LEVEL UNIT	LUm m: 0=dBm, 1=dBμ, 2=dBμ/m (1) 3=dBμ/m (2), 4=dBμ/m (3)	LUR
DISPLAY UNCAL	*	UCR
MARKER POINT	MP P1,P2 P1=0 to 255, P2=1 to 256 P1 + P2 < 256	*
DEVICE CLEAR	DC	*

Notes

1. An asterisk (*) indicates that no corresponding function is provided.
2. For further details on device messages, see paragraph 4.4.
3. Up to 64 bytes (64 characters) of a control message can be transferred at one time.

SECTION 3
GP-IB ADDRESS

3.1 Setting GP-IB Addresses

The address switches for setting the GP-IB address are on the rear panel of the MS610B/J. These five-bit binary switches can be set to address 1 to 30. When shipped, the address of MS610B/J is set to 00001 (address-1) as shown in Fig. 3-1.

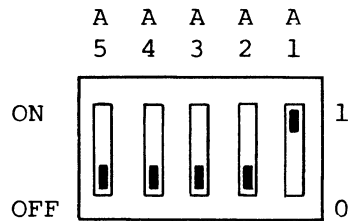

Fig. 3-1 Address switches

The switches for A1 to A5 can be set to the values listed below in Table 3-1.

Table 3-1

Address	A A A A A 5 4 3 2 1	Address	A A A A A 5 4 3 2 1	Address	A A A A A 5 4 3 2 1
0	0 0 0 0 0	10	0 1 0 1 0	20	1 0 1 0 0
1	0 0 0 0 1	11	0 1 0 1 1	21	1 0 1 0 1
2	0 0 0 1 0	12	0 1 1 0 0	22	1 0 1 1 0
3	0 0 0 1 1	13	0 1 1 0 1	23	1 0 1 1 1
4	0 0 1 0 0	14	0 1 1 1 0	24	1 1 0 0 0
5	0 0 1 0 1	15	0 1 1 1 1	25	1 1 0 0 1
6	0 0 1 1 0	16	1 0 0 0 0	26	1 1 0 1 0
7	0 0 1 1 1	17	1 0 0 0 1	27	1 1 0 1 1
8	0 1 0 0 0	18	1 0 0 1 0	28	1 1 1 0 0
9	0 1 0 0 1	19	1 0 0 1 1	29	1 1 1 0 1
				30	1 1 1 1 0

Notes

1. Do not change the address switches while the power is on.
2. Do not set the address switches to 11111.

SECTION 4
DEVICE MESSAGES

4.1 Outline of Device Messages

The commands that control the MS610B/J and read out the data are called device messages, of which there are two types.

Control messages control the MS610B/J, and data request messages read data from the MS610B/J. The syntax rules for these messages are explained below.

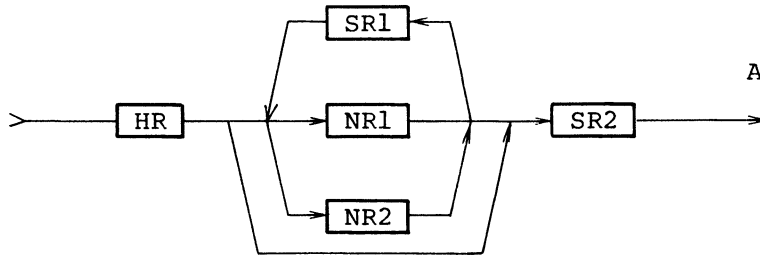

(1) HR (header) field

HR is located at the head of a device message and indicates the type or contents of data to be handled. With the MS610B/J, this field contains two or three alphabetic characters that correspond to a front panel function label. If an undefined HR is specified, it is ignored.

(2) NR (numeric) field

This is a data field indicating numeric values. The following two formats can be used with the MS610B/J:

- NR1 format ... Integer
- NR2 format ... Real number

(3) SR (separator) field

This is a separation symbol field that indicates the end of a data value or a message. When several messages are transmitted sequentially, the SR field is inserted between messages to serve as an end mark for each message transmission and as a start mark for the next message. The following two types can be used with the MS610B/J:

- . SR1 type ... Comma (,)
- . SR2 type ... Line feed (0A in hexadecimal ASCII code)

4.2 Control Message Formats

The MS610B/J accepts the four message formats explained below. Commands used with the Packet III Technical Computer (Anritsu) are used to explain these formats.

4.2.1 Format 1

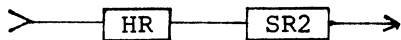

This message consists of HR and SR2. The MS610B/J has the following commands:

- (1) SS
- (2) DC

[Program example]

```
10 WRITE @1 01:"DC"
```

HR

GP-IB address of MS610B/J

Packet III interface
select code

Note

When the above command is executed, SR2 is sent automatically after HR.

4.2.2 Format 2

This message consists of HR, NR, and SR2. The MS610B/J has the following commands:

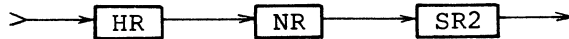

- (1) FDn
- (2) FQf
- (3) RMn
- (4) RLl
- (5) SAn
- (6) SPm
- (7) ATm
- (8) RSn
- (9) RBm
- (10) STm
- (11) CSn

- (12) CRn
- (13) VFm
- (14) SCm
- (15) TGm
- (16) LUm

[Program esample]

```

10 WRITE @101:"SP4"

```

Notes

1. When the above command is executed, SR2 is automatically sent following the NR (numeric) field.

 2. The ℓ in RL ℓ means NR2, and the other NR, (f,m, and n for example) all mean NR1.
-

4.2.3 Format 3

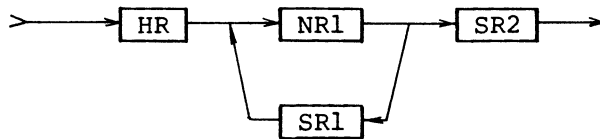

In this message format, the combination of NR1 and SR1 are repeated several times between an HR and SR2. The MS610B/J has the following commands.

(1) MP P1, P2

[Program example]

```
10 WRITE @101:"MP 110,50"
```

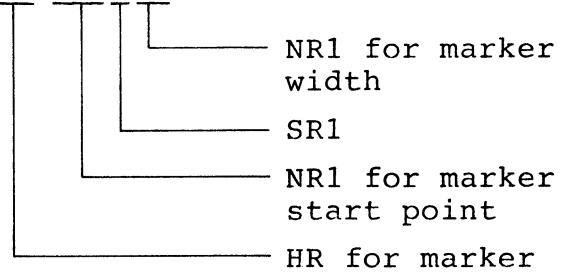

Note

When the above command is executed, SR2 is automatically sent following 50 NR1.

4.2.4 Format 4

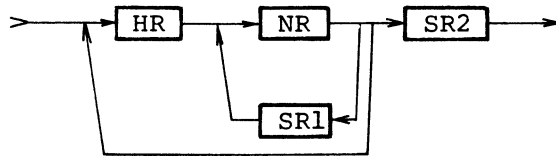

This format is used to transfer two or more control messages at one time.

[Program example]

```
10 WRITE @101:"FDO SP4 FQ1000 CS1 CR1"
```

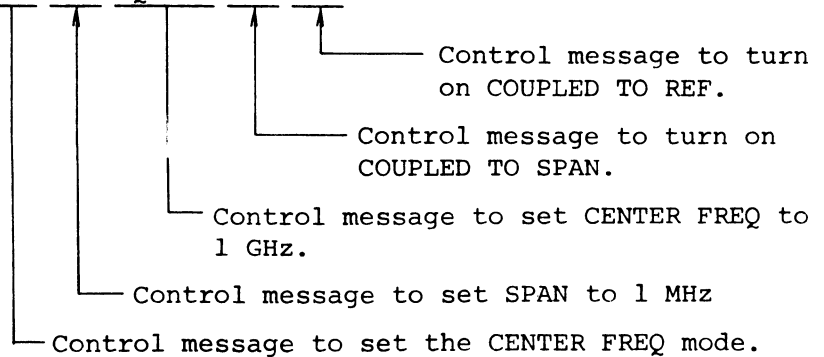

Notes

1. When the above command is executed, SR2 is automatically sent following the CR1 control message.
 2. Up to 64 bytes can be transmitted in format 4, including SR2.
 3. DC control messages cannot be transmitted in Format 4.
-

4.3 Data Request Message Format

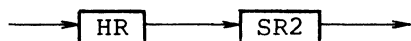

Data request messages can only be in the above format. The header of the data request message is expressed by adding R to the control message HR. The data output from the MS610B/J includes the request message HR, at this time without the additional R, plus SR2 (line feed) at the data end.

[Program example (1)]

```
10 WRITE @101:"SPR"  
      ↑  
      | Data request message to read  
      | out SPAN  
  
20 READ @101: A$  
      ↑  
      | Data read from the MS610B/J is  
      | input to variable A$.  
      |  
      | A$ = SP4
```

[Program example (2)]

MARKER LEVEL (at -12.3 dBm) is read in and stored in a numeric variable.

```
10 WRITE @101:"MLR" !request MARKER LEVEL
20 READ @101:A$ !A$=ML-12.3
30 L=VAL (A$(3:LEN(A$))) !L=-12.3
```

4.4 Details of Device Messages

4.4.1 FDn (FDR) - CENTER FREQ/START FREQ

The set frequency is switched to CENTER FREQ or START FREQ.

n	Mode
0	CENTER FREQ
1	START FREQ

4.4.2 FQf (FQR) - FREQUENCY

Frequency is set. f is in MHz.

Setting frequency accuracy is less than 20 MHz.

f = 0 to 2020 (MHz)

Notes

1. If f is sent in NR2 (read number), this device message is not executed.
 2. If the MS610B/J is switched to LOCAL, the set frequency returns to the frequency set by the COARSE dial. At this time, the frequency set by the dial cannot be read out.
 3. Settings of less than 1 MHz are done using the FINE dial, even if GP-IB mode.
 4. When FREQ SPAN is at FULL, frequency setting is impossible.
-

4.4.3 RMn (RMR) - REF/MARKER

The mode is switched to REFERENCE LEVEL or MARKER LEVEL.

n	Mode
0	REFERENCE LEVEL
1	MARKER LEVEL

Note

This control message cannot be executed when LINEAR SCALE or FULL SPAN is set.

4.4.4 RL ℓ (RLR) - REFERENCE LEVEL

The REFERENCE LEVEL is set. ℓ is in dBm.

SCALE	ℓ (dBm)	Resolution (dB)
10dB/div	-50.0 to (+)20.0	1
2dB/div	-50.0 to (+)20.0	0.5
LINEAR	-60.0 to (+)20.0	0.5
(QP) 5dB/	-50.0 to (+)20.0	0.5

Note

This control message cannot be executed if resolution values other than the above are sent.

4.4.5 * (MLR) - MARKER LEVEL

Marker level is read out.

Note

If, after the power supply is turned on, MLR is executed before the MARKER MODE obtained, "ML-199.9" is output.

4.4.6 SAn (SAR) - SPAN/ATTEN

The mode is switched to FREQ SPAN or INPUT ATTEN.

n	Mode
0	FREQ SPAN
1	INPUT ATTEN

4.4.7 SPm (SPR) - FREQ SPAN

FREQ SPAN is set.

m	SPAN (Hz)
0	0
1	100K
2	200K
3	500K
4	1M
5	2M
6	5M
7	10M
8	20M
9	50M
10	100M
11	200M
12	500M
13	1G
14	2G (FULL SPAN)

4.4.8 ATm (ATR) - INPUT ATTEN

INPUT ATTEN is set.

m	ATTEN (dB)
0	0
1	10
2	20
3	30
4	40
5	50

Notes

1. The setting range depends on the REFERENCE LEVEL or LINEAR SCALE.
Refer to the Operation Manual of the MS610B/J Spectrum Analyzer for details.
 2. When ATm is executed, COUPLED TO REF goes off.
-

4.4.9 RSn (RSR) - RBW/SWEEP T

The mode is switched to RBW or SWEEP TIME.

n	Mode
0	RBW
1	SWEEP TIME

Note

When RSn is executed, COUPLED TO SPAN goes off.

4.4.10 RBm (RBR) - RBW

RBW is set.

m	RBW (Hz)
0	1K
1	3K
2	9K
3	10K
4	30K
5	100K
6	120K
7	300K
8	1M

Notes

1. 9 kHz and 120 kHz are the RBWs at (QP) 5dB/SCALE (Option 02).
 2. When RBm is executed, COUPLED TO SPAN goes off.
-

4.4.11 STm (STR) - SWEEP TIME

A SWEEP TIME is set.

m	SWEEP TIME
0	10ms
1	20ms
2	50ms
3	100ms
4	200ms
5	500ms
6	1s
7	2s
8	5s
9	10s
10	20s
11	30s
12	40s
13	50s
14	60s
15	70s
16	99s

Notes

1. 20 to 99s cannot be set other than at (QP) 5dB/SCALE (Option 02).
 2. When STm is executed, COUPLED TO SPAN goes off.
-

4.4.12 CSn (CSR) - COUPLED TO SPAN

COUPLED TO SPAN is switched.

n	COUPLED TO SPAN
0	OFF
1	ON

Notes

1. When CS1 is executed, RBW and SWEEP TIME are automatically set to optimum values.
 2. This control message cannot be executed at (QP) 5dB/SCALE (Option 02).
-

4.4.13 CRn (CRR) - COUPLED TO REF

COUPLED TO REF is switched.

n	COUPLED TO REF
0	OFF
1	ON

Notes

1. When CR1 is executed, INPUT ATTEN is set to an optimum value.
 2. This control message cannot be executed at (QP) 5dB/SCALE (Option 02).
-

4.4.14 VFm (VFR) - VIDEO FILTER

VIDEO FILTER is switched.

m	VIDEO FILTER
0	OFF
1	10kHz
2	100 Hz

Note

This control message cannot be executed at (QP) 5dB/SCALE (Option 02).

4.4.15 SCm (SCR) - SCALE

SCALE is set.

m	SCALE
0	10dB/div
1	2dB/div
2	LINEAR
3	(QP) 5dB/

Note

When the SC3 is executed, COUPLE TO SPAN goes off,
COUPLED TO REF comes on, VIDEO FILTER goes off,
and RBW is set to 120 kHz.

4.4.16 TGm (TGR) - TRIG

The TRIGGER mode is switched.

m	TRIGGER
0	FREE RUN
1	LINE
2	VIDEO
3	SINGLE

4.4.17 SS (*) - START (SINGLE)

A sweep operation is started when the TRIGGER is
SINGLE.

4.4.18 LUm (LUR) - LEVEL UNIT

LEVEL UNIT mode is switched.

m	LEVEL UNIT
0	dBm
1	dBμ
2	dBμ/m (1)
3	dBμ/m (2)
4	dBμ/m (3)

Note

When the LEVEL UNIT mode is changed from REMOTE to LOCAL, the mode returns to the level unit determined by the REFERENCE LEVEL switch on the rear panel.

4.4.19 * (UCR) - DISPLAY UNCAL

The DISPLAY UNCAL state is read out.

UC0	NO UNCAL
UC1	UNCAL

4.4.20 MPP1,P2 (*) - MARKER POINT

A marker is set. The horizontal axis on the CRT can be divided into 256 segments.

P1: Marker start point (0 to 255)

P2: Marker width (1 to 256)

$P1+P2 \leq 256$

Note

Control operations are possible in MARKER LEVEL mode.

4.4.21 DC (*) - DEVICE CLEAR

All MS610B/J functions are returned to the initial power on status.

Note

DC control messages cannot be transmitted in format 4.

For details on format 4, see paragraph 4.2.4.

SECTION 5

APPLICATION PROGRAMS

5.1 Level measurement

This program reads and displays the maximum level signal that can be received when CENTER FREQ is set to 50 MHz and FREQ SPAN is set to 10 MHz.

```
10 !*** EXAMPLE 1 ***
20 LET SPA=101          ----- MS610B/J GP-IB address
30 WRITE @SPA:"DC"      ----- Device Clear
40 WRITE @SPA:"FD0SP7F050CS1CR1"
50 WRITE @SPA:"RM1"     ----- MS610B/J setting
60 WRITE @SPA:"MPO,256" ----- Marker setting
70 WAIT DELAY .5        ----- Sweep completion wait
80 WRITE @SPA:"MLR"     ----- Marker level reading
90 READ @SPA:A$         ----- Data is input to variable A$.
100 LET LEVEL=VAL(A$(3:LEN(A$))) ----- Data is stored in a numeric
110 PRINT USING "LEVEL= ####.# dBm":LEVEL ----- Print      variable
120 END
```

5.2 Harmonic Spurious Signal Measurement

This program measures and displays up to the tertiary harmonic wave when the fundamental frequency is 50 MHz.

```

10 !*** EXAMPLE 2 ***
20 LET SPA=101
30 WRITE @SPA:"DC"
40 WRITE @SPA:"FD0SP7FQ50CS1CR1" ] MS610B/J setting
50 FOR N=1 TO 3 ]
60 LET A=N*50 ] Harmonic wave order
70 IF A>2000 THEN STOP ] CENTER FREQ values
80 WRITE @SPA:"FQ",A ] CENTER FREQ setting
90 WRITE @SPA:"RL20"
100 FOR I=0 TO 2
110 WRITE @SPA:"RN1"
120 WRITE @SPA:"MPO,256"
130 WAIT DELAY .5
140 WRITE @SPA:"MLR"
150 READ @SPA:B#
160 LET LEVEL=VAL(B#(3:LEN(B#)))
170 LET REF=INT(LEVEL)
180 IF REF<-50 THEN LET REF=-50
190 WRITE @SPA:"RL",REF
200 NEXT I
210 LET L(N)=LEVEL
220 NEXT N
230 PRINT USING "Fundamental LEVEL= ####.# dBm":L(1)
240 PRINT USING " 2nd LEVEL= ####.# dBm":L(2)
250 PRINT USING " 3rd LEVEL= ####.# dBm":L(3)
260 END

```

Marker level measurement

Marker level is set to the reference level

5.3 Frequency Characteristic Measurement (CRT Display Transfer to Packet III CRT)

This program divides the CRT horizontal axis by Marker points and stores the maximum level of each point. It also displays the spectrum data of the MS610B/J with the parameters and the scale lines on the Packet III CRT.

```

10 ! *** EXAMPLE 3 ***
20 ! * MAIN ROUTINE *
30 CLEAR
40 LET SPA=101
50 SET VIEWPORT 47,137,21,90
60 SET WINDOW 0,896,0,768
70 GO SUB 420
80 GO SUB 120
90 GO SUB 230
100 WRITE @SPA:"TBO" -----
110 STOP
120 ! * GRATICULE *
130 SET LINE STYLE 2
140 PLOT
150 FOR I=0 TO 8
160 PLOT 0,I*96;896,I*96
170 NEXT I
180 FOR I=0 TO 10
190 PLOT I*89.6,0;I*89.6,768
200 NEXT I
210 SET LINE STYLE 1
220 RETURN
230 ! * SPECTRUM *
240 DIM L(253)
250 WRITE @SPA:"RM1"
255 WAIT DELAY ST*2
260 WRITE @SPA:"TG3"
270 WRITE @SPA:"SS"
280 WAIT DELAY ST*2
290 FOR N=0 TO 252 STEP 1
300 WRITE @SPA:"MP"&STR$(N)&",";1"
310 WRITE @SPA:"SS"
320 WAIT DELAY ST+.1
330 WRITE @SPA:"MLR"
340 READ @SPA:B#
350 LET L(N)=VAL(B$(3:LEN(B#)))
360 LET H=A*(L(N)-REF+B)
370 IF H<-19.2 THEN LET H=-19.2
380 IF H>787.2 THEN LET H=787.2
390 PLOT N*896/253,H;
400 NEXT N
410 RETURN

```

Packet III CRT setting

Main routine

SCALE line display

----- Marker level setting

----- Single trigger setting

]--- Sweep time read-in

----- Marker setting

----- Sweep completion wait

----- Marker level is stored in a numeric variable

----- Marker level is converted for display

] Display upper and lower limit settings

Horizontal axis setting

Spectrum data storage

```

420 ! * SETTING PARAMATER *
430 WRITE @SPA:"SCR"
440 READ @SPA:SC$
450 IF SC$="SC0" THEN
460 LET A=9.6%LET B=80
470 END IF
480 IF SC$="SC1" THEN
490 LET A=48%LET B=16
500 END IF
510 WRITE @SPA:"STR"
520 READ @SPA:ST$
530 IF ST$="ST4" THEN LET ST=.2
540 IF ST$="ST3" THEN LET ST=.1
550 WRITE @SPA:"RLR"
560 READ @SPA:RL$
570 LET REF=VAL(RL$(3:LEN(RL$)))
580 ! * PARAMATER DISPLAY *
590 WRITE @SPA:"FQR"
600 READ @SPA:FQ$
610 PRINT FQ$
620 WRITE @SPA:"SPR"
630 READ @SPA:SP$
640 PRINT SP$
650 PRINT RL$
660 PRINT SC$
670 WRITE @SPA:"RBR"
680 READ @SPA:RB$
690 PRINT RB$
700 WRITE @SPA:"VFR"
710 READ @SPA:VF$
720 PRINT VF$
730 WRITE @SPA:"ATR"
740 READ @SPA:AT$
750 PRINT AT$
760 PRINT ST$
770 RETURN
780 END

```

Parameter setting
to display the
LOG SCALE

Sweep time read out
(Sweep time is
limited here on the
COUPLED TO SPAN mode.)

Reference level
read out

Parameter setting
to read spectrum
data

Display of set
parameters

[Example of BPF measurement]

FQ202
SP10
RL-14.0
SC0
RB4
VF0
AT2
ST4

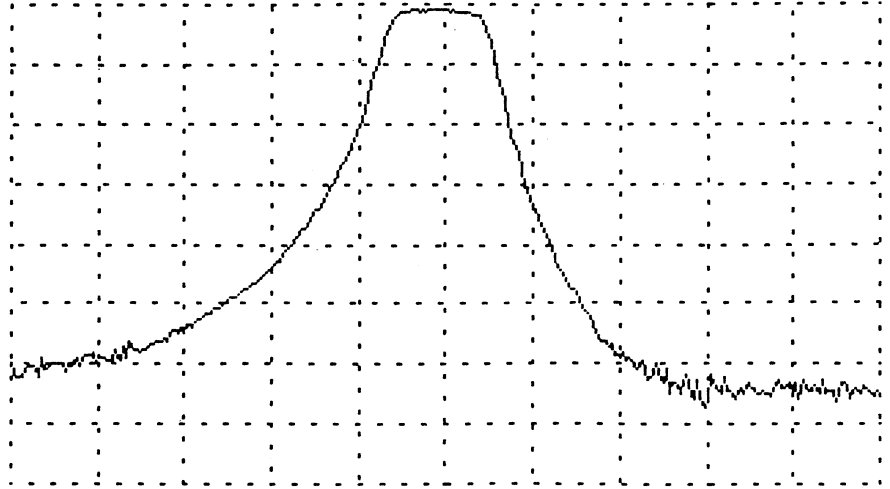

OPERATION MANUAL
SPECTRUM ANALYZER
MS610B/J RADIO INTERFERENCE
MEASURING OPTION
(OPTION 02)

CONTENTS

	Page
SECTION 1 GENERAL	1-1
SECTION 2 SPECIFICATIONS	
2.1 Basic Standards	2-1
2.2 Pulse Repetition Frequency Response Characteristics	2-1
SECTION 3 BASIC IDEAS FOR MEASUREMENT	
3.1 Efficient Measurement in the Combined LOG and Quasi Peak (QP) Modes	3-1
3.2 Basic Measurement Procedures	3-1
SECTION 4 MEASUREMENT PROCEDURES	
4.1 General Measurement	4-1
4.2 Measurement Using a Specified Antenna	4-3
SECTION 5 MEASUREMENT PRECAUTIONS	
5.1 Calibration of the Displayed Frequency	5-1
5.2 Consideration for Saturation Level	5-2
5.2.1 Use of preselector	5-2
5.2.2 Setting the level	5-2
5.3 Measurement of Weak Interference Voltages	5-3
5.4 Frequency Sweep and Sweep Time	5-3
SECTION 6 OPTIONAL DEVICE (ARTIFICIAL MAINS NETWORK)	6-1

SECTION 1

GENERAL

Because of Radio interference generated by such devices in the home as vacuum cleaners or personal computers, television images are often distorted and FM radio signals are often impaired by noise.

To prevent the Radio interference described above, regulations have been acted upon recently in regard to RF interference generated by electrical machinery.

Many countries have adopted the CISPR recommendations for their regulations, for example, FCC Standards in the U.S.A and VDE Standards in West Germany.

The MS610B/J Radio Interference Measuring Option has functions conforming to CISPR recommendations and can make measurements according to CISPR recommendations.

SECTION 2
SPECIFICATIONS

This option has a quasi-peak value detector conforming to CISPR Pub. 16 Standards. The standards are shown below.

In the FCC Standards, the contents of Section J in Chapter 15 are almost the same as CISPR Pub. 16 Standards. Therefore, this option can be used for measurements conforming to CISPR Standards and FCC Standards.

2.1 Fundamental Characteristics

		CISPR Standard		MS610B/J Specifications	
Frequency range		150 k- 30 MHz	30 M- 1000 MHz	150 k- 30 MHz	30 M- 1000 MHz
6 dB bandwidth		9 kHz	120 kHz	9 kHz	120 kHz
Detector time constant	Charge time		1 ms		1 ms
	Discharge time	160 ms	550 ms	160 ms	550 ms
Mechanical time constant		160 ms	100 ms	160 ms	100 ms

2.2 Pulse Repetition Frequency Response Characteristics

CISPR Pub. 16 regulates pulse repetition frequency response characteristics. Actual measured values by the MS610B/J Radio Interference Measuring Option for pulse repetition frequency response characteristics are shown below. They satisfy CISPR Pub. 16 Standards.

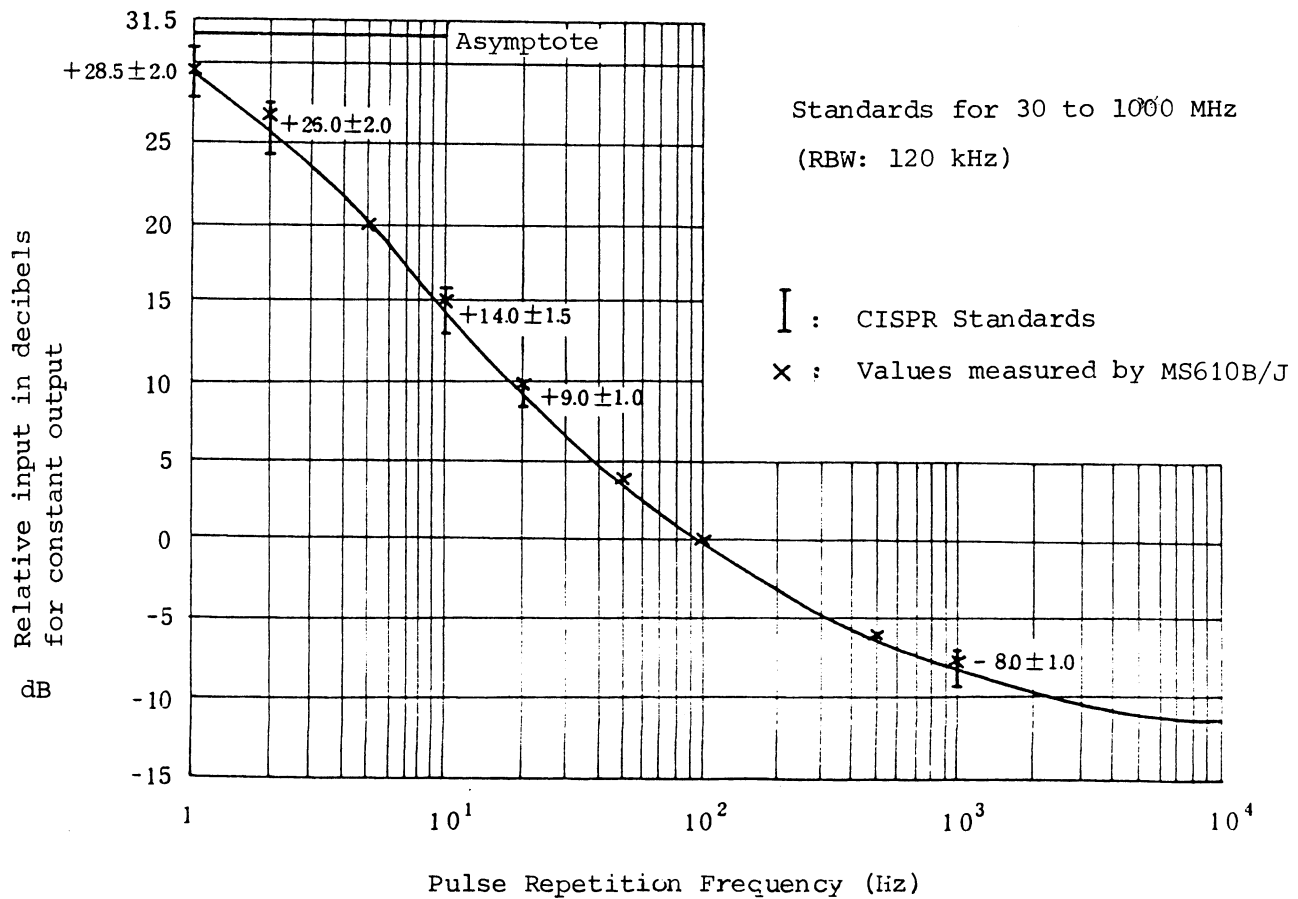
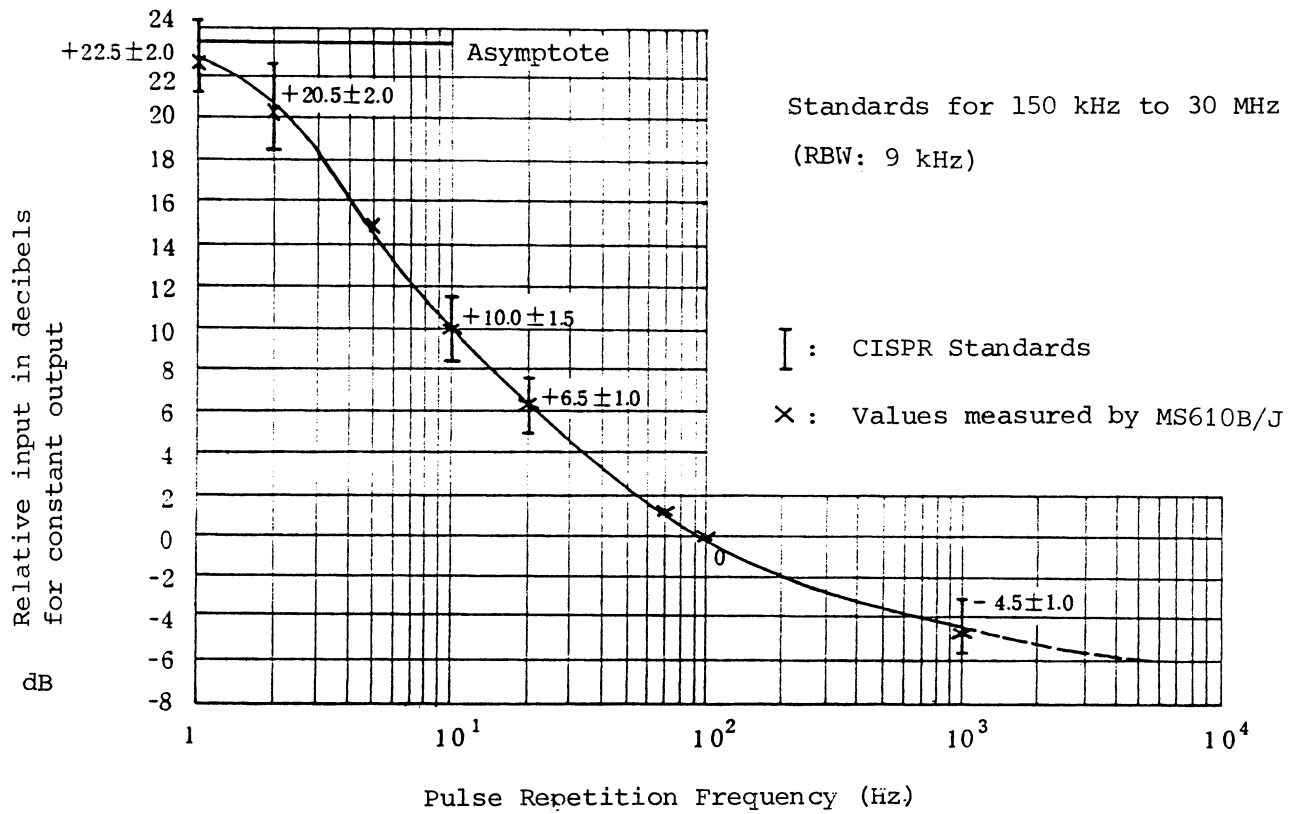

SECTION 3

BASIC IDEAS FOR MEASUREMENT

3.1 Efficient Measurement in the Combined LOG and Quasi Peak (QP) Modes

The following differences exist between the LOG mode and the QP mode in measuring radio interference:

- (1) The measured value in the QP mode is always less than in the LOG mode.
- (2) The detector charging/discharging time constant in the QP mode is larger.
- (3) For a frequency sweep, the QP mode requires a much longer measurement than the LOG mode.

Because of the differences explained above, the best way to measure is to combine the LOG and QP modes as follows.

3.2 Basic Measurement Procedures

- (1) Receive an entire radio interference in the LOG mode.
- (2) Receive the wave to be measured with the zero sweep.
- (3) Measure radio interference by switching the LOG mode to the QP mode.

SECTION 4
MEASUREMENT PROCEDURES

4.1 General Measurement

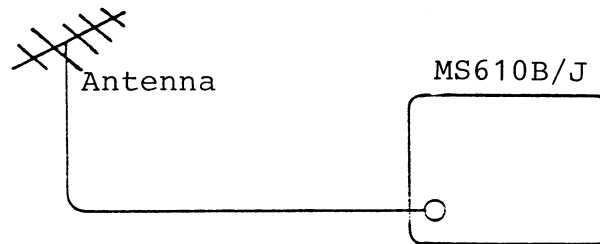

- (1) Connect an antenna or an artificial mains network to the MS610B/J Spectrum Analyzer.

Receiving radio interference:

- (2) Receive an entire radio interference in the LOG mode (SCALE 10 dB/DIV).
- (3) Set 9 kHz RBW in the case of the frequency range from 150 kHz to 30 MHz, or 120 kHz RBW from 30 to 1000 MHz.
- (4) Adjust the REF level so that the radio interference to be measured is close to the topmost line on the tube surface.

Align the wave at the center of the tube surface with the COARSE and FINE dials.

Checking the saturation level:

- (5) Increment the input attenuator (INPUT ATTEN) setting by 10 dB (Example: For 0 dB, set 10 dB). At this time, check that the radio interference at the center of the tube surface change 1 dB or less. If a change exceeding 1 dB occurs, it is caused by saturation in

the MS610B/J; therefore, take countermeasures as specified in paragraph 5.2.

- (6) Set the frequency sweep to zero sweep.

Checking the INPUT ATTEN setting:

- (7) Check the INPUT ATTEN setting by pressing the INPUT ATTEN key.

Measurement in QP mode:

- (8) Set 5-dB SCALE (QP).

Note:

5-dB SCALE can be set when RBW is set to 9 or 120 kHz and VIDEO FILTER to OFF.

- (9) Change the REF level so that the wave is aligned with the -40 dB line (the lowest line) on the tube surface (the CISPR standards are satisfied).

Check that the INPUT ATTEN setting has not changed.

- (10) When the INPUT ATTEN setting has changed:

Adjust the setting to restore the setting before the REF level was changed.

With this operation, input levels to the initial stage mixer are equalized, thereby obtaining the best input level to the mixer.

If the setting before the REF level was changed is not obtained, the S/N ratio deteriorates depending on the difference from the setting before the REF level was changed. An S/N ratio of 12 dB or more is required to prevent measurement errors.

Calculating measured value:

(11) Method 1

Obtain deviation from the -40 dB line on the CRT
(within +0.5 dB).

The measured value is as follows:

Measured value (dBm) = (REF level value - 40) +
(deviation from -40 dB line)

Method 2

Press the MARKER key.

The measured value at the marker point is directly
displayed in units of dB μ .

Measured value when an antenna is used:

(12) The measured value when an antenna is used is:

Measured value (dB μ /m) = (Measured value in item (11))
- (Antenna factor at
measurement frequency)

(For an accurate antenna factor, the measurement
frequency must be calibrated. For calibration, see
paragraph 5.1.)

4.2 Measurement Using a Specified Antenna

When any of the following antennas are used, the radio
interference can be measured using direct digital display
without antenna factor correction because the antenna
factor is internally memorized.

Relationship between the specified antennas and the REF LEVEL switches

Switch number	2	3	4
Units	dB μ /m (1)	dB μ /m (2)	dB μ /m (3)
Antenna model	MP534A	MP635A	MP636A
Type	Dipole antenna	Log-periodic antenna	Log-periodic antenna
Frequency range	25 - 520 MHz	80 - 1000 MHz	300 - 1700 MHz

- (1) Set the REF LEVEL switch according to the specified antenna using the above table.
- (2) For receiving radio interference, check the saturation level and the INPUT ATTEN setting and make measurements in the QP mode, and use the same procedures for general measurements.

Measured value:

- (3) Set the MARKER key to ON,

The radio interference voltages converted by the antenna factor for the displayed frequency is displayed on the marker measurement display in units of dB μ /m.

(For an accurate antenna factor, the measurement frequency must be calibrated. For calibration, see paragraph 5.1.)

Displaying the antenna factor:

Pressing the DATA key \wedge with the MARKER LEVEL key set to ON displays only the antenna factor for the displayed frequency.

To switch the display to a display using dB μ /m, press the DATA key \wedge .

SECTION 5

MEASUREMENT PRECAUTIONS

5.1 Calibration of the Displayed Frequency

The MS610B/J frequency accuracy is ± 10 MHz. To obtain an accurate antenna factor, the displayed frequency must be calibrated.

The CAL signal is used to calibrate the displayed frequency.

The displayed frequency should be calibrated before starting measurements or after determining the measurement frequency in the LOG mode.

- (1) Connect the CAL signal to the RF input.

The CAL signal generation frequency is:

CAL signal = (50 MHz \pm 150 kHz) + Harmonics up to N-order

$$N \cong 10$$

- (2) Position the N-order harmonics of the CAL signal near the radio interference to be measured, and align the signal to the center of the CRT with the COARSE and FINE dials.
- (3) To obtain the same display as the N-order frequency, turn the "FREQ ZERO ADJ" semi-fixed volume knob with a screwdriver.

$$\text{N-order harmonics} = (50 \times N) \text{ MHz}$$

5.2 Considering the Saturation Level

When intense external radio interference is measured or when the MS610B/J level setting is improper, distortion or saturation may occur in the MS610B/J. This can cause measurement errors.

Therefore, distortion and saturation level must be taken into account in radio interference measurement.

5.2.1 Use of preselector

In measuring radio interference at an open site where external radio interference is intense, distortion or saturation occurs in the MS610B/J because of excessive input even when the MS610B/J level setting is correct. As a result of this, the signal to be measured is masked, and identifying the signal becomes very difficult, or an error in measurement occurs. In this case, a preselector is required. The MS610B/J is designed so that no internal saturation occurs when the preselector bandwidth is 6 MHz or less; therefore, it is better to insert a preselector with bandwidth of 6 MHz or less in the MS610B/J input for excessive input.

5.2.2 Setting the level

Incorrect INPUT ATTEN setting causes distortion or saturation in the input mixer. Therefore, the INPUT ATTEN setting must be correct.

To check for saturation:

- (1) Change the INPUT ATTEN setting by 10 dB in the LOG move. At this time, if the radio interference level difference is within 1 dB, there is no saturation.

(When maximum sensitivity is reached, this setting operation cannot be carried out; therefore, use the following method.)

- (2) Insert an attenuator variable in increments of 1 dB to the MS610B/J input terminal.

For the amount of attenuation, only 40 dB is required.

Check relationship with the reception level when changing attenuator attenuation in increments of 1 dB.

The 1 dB compression level is the lower bound of the saturation level. Up to this level, the MS610B/J can correctly make measurements.

5.3 Measurement of Weak Radio Interference

The MS610B/J sensitivity determines measurement limitations.

If sufficient sensitivity cannot be obtained for the CISPR standards, use a preamplifier.

Note that the MS610B/J saturation level is lower by the value of the preamplifier gain in this case.

To prevent errors, an S/N ratio of 12 dB or more is required.

5.4 Frequency Sweep and Sweep Time

When the radio interference is measured in the QP mode, it is best to use zero sweep. However, continuous sweep can also be used. In this case, longer sweep time is required for correct measurements. Too short sweep a time causes an error of several dB or more in the level.

Primary causes of this error are:

- (1) Overshoot or ringing that occurs in the filter to determine the resolution bandwidth

- (2) A long time is required to obtain the true value because the charging/discharging time constant of the quasi-peak value detector or the mechanical time constant is too great.
- (3) When the pulse repetition frequency is low (1 to 2 Hz), IF filter pulse seizure ratio is low. To obtain a measured value near the true value, several pulses or more must be received. Therefore, when the radio interference is measured by a frequency sweep, take the above factors into consideration and secure sufficient sweep time.

SECTION 6
 OPTIONAL DEVICE
 (ARTIFICIAL MAINS NETWORK)

For frequency bands of 30 MHz or less, EMI conduction measurements are performed with the artificial mains network.

Anritsu can provide various artificial mains networks shown below:

Model	MN423A	MN424A	MN425A
Frequency range	150k - 30MHz	450k - 30MHz	10k - 30MHz
Impedance	75 Ω	50 Ω	50 Ω
Conformable standards	CISPR Pub 1	FCC Part 15	VDE 876

Notes:

- (1) The voltage display of the MS610B/J is that of terminating value.

MS610J : 0 dBm = 109 dB μ

MS610B : 0 dBm = 107 dB μ

- (2) The MS610B Spectrum Analyzer has 50 Ω input impedance, and the MS610J Spectrum Analyzer has 75 Ω input impedance.

When the impedance of the artificial mains network is different from the Spectrum Analyzer, match the impedance with an impedance converter.