

FR-5A/U FREQUENCY METER  
**FR-5/U FREQUENCY METER**

**10-100 MEGACYCLES**

**Basic Freq X Harmonic  
Number = Input Frequency**



571-300-004

# FREQUENCY METER FR-5/U

## OPERATING INSTRUCTIONS

### PRELIMINARY INSTRUCTIONS

Open door at rear of instrument, remove power cord, and insert plug into a suitable 115 volt, 50 to 1000 cps, a-c power source. For 230 volt operation, refer to the technical manual. Turn POWER switch to right, insert headphone plug into PHONE jack and couple RF INPUT coaxial connector to the source of unknown frequency. Allow a minimum of 20 minutes warmup time.

### INSTRUCTIONS FOR MEASUREMENT OF UNKNOWN FREQUENCY

**STEP 1** Turn RANGE switch to the setting which includes the unknown frequency within its limits. If the approximate frequency is unknown, set RANGE switch to the lowest frequency band.

**STEP 2** With the LEVEL control fully clockwise and the FUNCTION SWITCH at COARSE, rotate COARSE tuning knob until an audio tone is heard in the headphones. If the approximate frequency is unknown, it may be necessary to switch bands in order to locate this tone. The approximate frequency in megacycles will be shown in the illuminated MEGACYCLES window of the COARSE tuning dial.

**STEP 3** Turn LEVEL control fully counter clockwise; then rotate LEVEL control clockwise until needle on TUNING METER is in the green LEVEL SET area. Carefully maximize meter reading by tuning COARSE knob. Readjust LEVEL control if necessary to keep needle of TUNING METER in green area.

**STEP 4** Turn FUNCTION SWITCH to FINE and rotate FINE tuning knob until a loud low frequency audio beat note is heard in the headphones. Tune to approximately zero beat.

**STEP 5** Calibrate the instrument as follows:

- a. Turn the FUNCTION SWITCH to CHECK.
- b. While looking into the FINE tuning window (above the FINE tuning knob) rotate FINE tuning knob until a black diamond shaped mark is lined up with the hairline on the window under CH'K (arrows on the film in the window point in the direction of the diamond).
- c. Carefully adjust the CHECK knob until the beat note, which should be heard in the headphones, goes to zero beat and the TUNING METER reading is zero.

**STEP 6** Return FUNCTION SWITCH to FINE and again rotate FINE tuning knob until the loud beat note is heard in the headphones. Carefully adjust the FINE tuning knob until a zero beat is heard in the headphones and the TUNING METER needle goes to zero or fluctuates slowly.

**NOTE:**—IF THE SIGNAL BEING MEASURED IS NOT SUFFICIENTLY STABLE IN FREQUENCY, AN ESTIMATE OF ZERO BEAT MUST BE MADE.

**STEP 7** Observe the illuminated HARMONIC window of the COARSE tuning dial to determine that hairline falls on numbered black rectangle. If not, a spurious beat note has been used or a mistake has been made. Steps 3, 4, 5, 6, and 7 must be repeated until a beat note is found for which the hairline does fall on a numbered black rectangle.

**STEP 8** The instrument is now tuned to the unknown frequency. Proceed to determine this frequency in the CALIBRATION TABLES as follows:

- a. Turn to the section of the CALIBRATION TABLES which is the same color as the illuminated portion of the COARSE tuning dial.
- b. Turn to the page number indicated under PG in the FINE tuning window.
- c. Read the BASIC FREQ. in the FINE tuning window and locate this number in the column of the CALIBRATION TABLES headed BASIC FREQ.
- d. Locate the HARMONIC column to be used on the COARSE tuning dial. This is presented as a numbered black rectangle in the illuminated HARMONIC window.
- e. At the intersection of the line containing the BASIC FREQ., found in Step 8c, and the HARMONIC column, found in Step 8d, read the frequency in MEGACYCLES PER SECOND. This is the frequency of the signal being measured.

### INSTRUCTIONS FOR SETTING TO DESIRED FREQUENCY

**STEP 1** Set the RANGE switch to the band which includes the desired frequency.

**STEP 2** Turn to the section of the CALIBRATION TABLES which is the same color as the illuminated portion

of the COARSE tuning dial. On page 1 of this section, determine, from the first frequency in each HARMONIC column, the HARMONIC which contains the desired frequency.

**STEP 3** Follow this HARMONIC column through the book and locate the desired frequency or the closest listed frequency to the desired.

**STEP 4** On the same line as this frequency, note the number in the column headed BASIC FREQ.

**STEP 5** Rotate the FINE tuning knob until this BASIC FREQ. appears in the FINE tuning window.

**STEP 6** Calibrate the instrument as described in Step 5 of INSTRUCTIONS FOR MEASUREMENT OF UNKNOWN FREQUENCY.

**STEP 7** Return the FUNCTION SWITCH to FINE and re-set the film in the FINE tuning window to the BASIC FREQ. found in Step 4.

**STEP 8** Rotate the COARSE tuning knob until the HARMONIC number found in Step 2 (number at top of column used) is under the hairline in the illuminated HARMONIC window of the COARSE tuning dial. A signal of the desired frequency is now available at the RF INPUT connector. Amplitude of this signal can be varied by means of the LEVEL control.





1. For the FR-5A/U only make the following changes on the enclosed schematic diagram of the FR-5/U:

- a. FR-5/U should be FR-5A/U
- b. V305 should be changed from 6AK6 to 6AH6
- c. V106 should be changed from 6BA6W/5749 to 6AH6
- d. C240, 2.2 UUF should be added from pin 6 to pin 8 of V202
- e. C241, 0.51 UUF should be added from pin 1 to pin 3 of V202



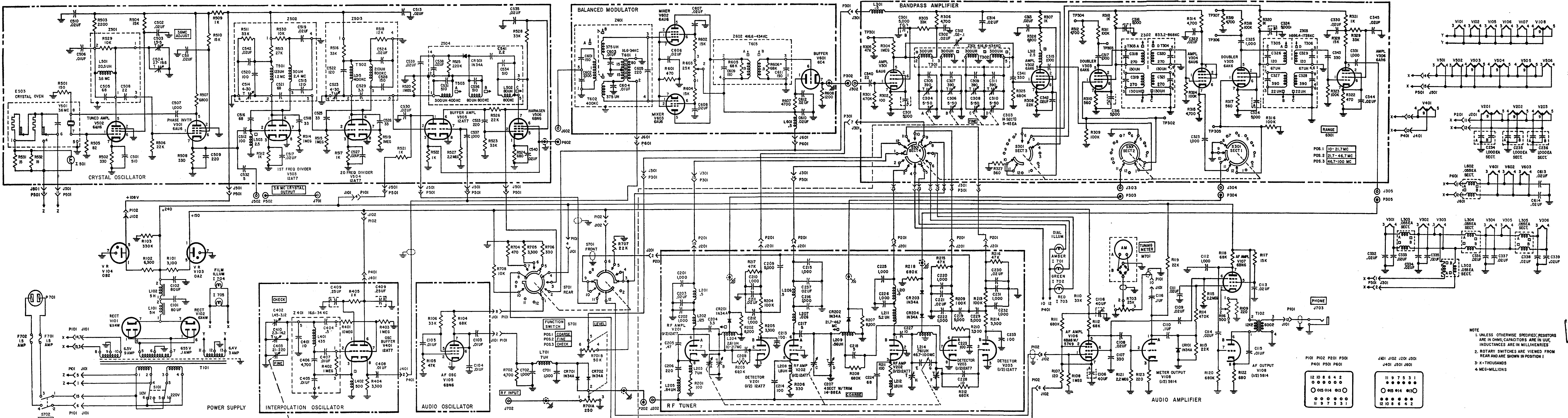

FREQUENCY METER FR-5/U SCHEMATIC DIAGRAM

NOTE  
 1. UNLESS OTHERWISE SPECIFIED, RESISTORS ARE IN OHMS; CAPACITORS ARE IN UF. INDUCTANCES ARE IN MILLIHENRIES.  
 2. ROTARY SWITCHES ARE VIEWED FROM REAR AND ARE SHOWN IN POSITION 1.  
 3. K=THOUSANDS  
 4. M= MILLIONS

