

AIWA®

S/M Code No. 83-014
DATE OF ISSUE 5/1983

SERVICE MANUAL

**STEREO CASSETTE
DECK**

MODEL NO.

AD-F990



TYPE. H, HU, U, E, K, G

Follow the instructions carefully, which will allow the user to optimise the products' performance and give many years of service.

1. No scratch and melting shall be made to covered lead-wires of an a.c. primary circuit including mains leads.
2. No illegibility shall be given to the specification plate, the caution labels, the fuse labels and others.
3. When, on pattern sides of circuit boards, additional repair-parts have been made up, the parts shall be firmly glued to circuit boards or other components, unless the parts can be attached firmly.
4. The following matters shall be maintained as they are, when repairing.
 - 1) Soldering of lead-wire ends
 - * Care should be taken of the space distance in an a.c. primary circuit as well as soldering.
 - 2) Wiring and holding of lead-wires with wire-clips and binders
 - 3) Materials of lead-wires
 - * e.g.: For UL models, lead-wires to be used shall be approved or accepted by the UL.
 - 4) Location of all kinds of insulators
 - 5) Setting of voltage selector switch
 - * Set the Voltage Selector Switch to 240V, 220V, or 120V, According to your Local Voltage.
5. After repaired, the insulation resistance or leakage current shall be measured with $500 \pm 5V$ D.C and shall be not less than $1M\Omega$.
6. General instructions for mechanism repair
 - 1) The heads, capstan and pinch roller shall be cleaned of good quality alcohol after repaired, because dirty heads shall cause distorted sounds while dirty capstan and pinch roller shall occur wow/flutter and take-up fault.
 - 2) Lubricants been stained the surfaces of transmitting portion of the belts, idlers, capstan and pinch roller shall be removed, because slippery and faulty tape travel shall be caused.
 - 3) When oiling, only one or two drops shall be applied so as not to run over and be dispersed. Note should be taken of the metal fitting for the capstan and rotating portions of the idlers and pinch roller, especially.
 - 4) E-rings and poly slider washers shall be replaced with new ones, if once those have been removed. — No re-utilization due to unreliability.
 - 5) Regular spare-parts shall always be used for repair, because using irregular parts and tampering with the products shall cause deterioration, malfunction and damage.

Measuring Point

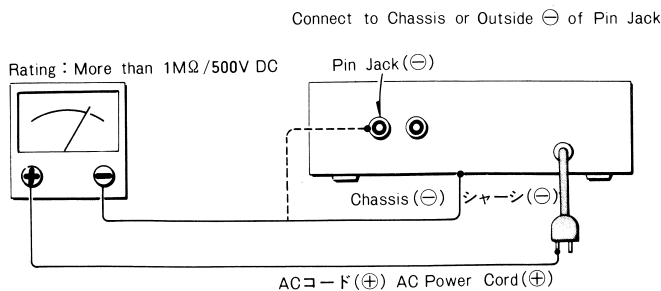

SPECIFICATIONS

Semiconductors:	611Cs, 116 transistors, 1 FET 138 diodes, 20 LED's		More than 48/57 dB (METAL, DOLBY-NR B OFF/ON)
Power supply:	H, HU models AC 120V/220V/240V switchable 50/60 Hz U model AC 120V, 60 Hz E model AC 220V, 50 Hz K, G models AC 240V, 50 Hz		More than 50/59 dB (CrO ₂ , DOLBY-NR B OFF/ON) More than 46/55 dB (NORMAL, DOLBY-NR B OFF/ON) More than 48/64 dB (METAL, DOLBY-NR C OFF/ON) More than 50/60 dB (CrO ₂ , DOLBY-NR C OFF/ON) More than 46/60 dB (NORMAL, DOLBY-NR C OFF/ON)
Power consumption:	40W		
Dimensions:	420(W) x 110(H) x 280(D) mm [16-1/2" x 4-3/8" x 11-1/4"]	Channel separation:	More than 30 dB (1 kHz, 0VU)
Weight:	5.5 kg (12.11 lbs)	Cross talk:	More than 60 dB (1 kHz, 0VU)
Track type:	4 tracks 2 channels	Erasing ratio:	More than 60 dB (125 Hz, 0VU + 10 dB, METAL)
Tape speed:	4.8 cm/s (1-7/8 ips) ± 1.5%	Level drift:	± 0.5 dB (10 kHz)
Wow & flutter:	0.025% (WRMS) According to DIN 45500 0.08%	Level indication error:	(-20VU) ± 5 dB (-10VU) ± 3 dB (-0VU) ± 1 dB (+2 ~ +6VU) ± 2 dB (+8 ~ +10VU) ± 2 dB
Automatic stop system:	Full auto stop	ADMS time:	2.0 ± 0.5s. (POWER ON) (ADMS LED light up time)
Automatic shut-off action time:	3 ± 1s.	Bias frequency:	85 kHz
Pinch roller pressure:	T side: 350 ± 30 g (3.43 ± 0.29N) S side: 165 ± 15 g (1.61 ± 0.15N)	Frequency response:	(0 dB Rec. DOLBY NR C ON) METAL : 20 ~ 20,000 Hz ± 3 dB (-20 dB Rec.) 20 ~ 18,000 Hz ± 3 dB (0 dB Rec.) CrO ₂ : 20 ~ 20,000 Hz ± 3 dB (-20 dB Rec.) 20 ~ 15,000 Hz ± 3 dB (0 dB Rec.) NORMAL : 20 ~ 19,000 Hz ± 3 dB (-20 dB Rec.) 20 ~ 11,000 Hz ± 3 dB (0 dB Rec.)
Take-up torque:	38 ± 10 g-cm (0.37 ± 0.11 mN·m)		
FF & rewind torque:	150 ⁺⁴⁰ ₋₃₀ g-cm (1.47 ^{+0.39} _{-0.29} mN·m)		
FF & rewind time:	60 ± 10s. (C-60)		
Counter indication error:	0 ± 3 digit (C-60)		
Cassette lid action time:	0.8 ± 0.4s. (at normal temperature)		
Playback output:	540 ± 50 mV (TTA-161)		
REC/PB output:	380 mV (27 kΩ, 0VU)		
REC/PB distortion:	Less than 1.5% (METAL) Less than 1.5% (CrO ₂) Less than 1.5% (NORMAL) Less than 2.7 mV (NORMAL DOLBY NR OFF) Less than 1.5 mV (NORMAL DOLBY NR B) Less than 1.2 mV (NORMAL DOLBY NR C) Less than 2.0 mV (METAL, CrO ₂ , DOLBY NR OFF) Less than 1.2 mV (METAL, CrO ₂ , DOLBY NR B) Less than 1.0 mV (METAL, CrO ₂ , DOLBY NR C) Less than 1.2 mV (NORMAL DOLBY NR OFF) Less than 0.6 mV (NORMAL DOLBY NR B) Less than 0.6 mV (NORMAL DOLBY NR C) Less than 1.0 mV (METAL, CrO ₂ , DOLBY NR OFF) Less than 0.5 mV (METAL, CrO ₂ , DOLBY NR B) Less than 0.5 mV (METAL, CrO ₂ , DOLBY NR C) (400 Hz, 0VU)		
Playback noise:	(Unweighted)		
	(WTD-A)		
REC/PB SN ratio:	(Unweighted) More than 44/47 dB (METAL, CrO ₂ , DOLBY-NR B OFF/ON) More than 42/45 dB (NORMAL, DOLBY-NR B OFF/ON) More than 44/49 dB (METAL, CrO ₂ , DOLBY-NR C OFF/ON) More than 42/48 dB (NORMAL, DOLBY-NR C OFF/ON)	Motor:	DC Servomotor for capstan DC motor for reels
		Head:	DX Combination head (for REC/PB) Double gap semidust head (for erase)
		Inputs:	MIC maximum input sensitivity: 1 mV (200 Ω - 10 kΩ matched) LINE IN maximum input Sensitivity: 50 mV (more than 50 kΩ)
		Outputs:	LINE OUT/PLAY standard output level: 0.38V (0VU); suitable load impedance: more than 50 kΩ; Headphones: 8 Ω
		Test tape:	METAL TTA-119MX NORMAL TTA-119J CrO ₂ TTA-119G

- Specifications and external appearance are subject to change without due to product improvement.
- Noise reduction system manufactured under license from Dolby Laboratories Licensing Corporation.
- Dolby and the  symbol are trademarks of Dolby laboratories Licensing Corporation.
- HX professional originated by BANG & OLUFSEN.

As to the disassembling instructions, refer to the service manual of AD-F660.

SPRING APPLICATION POSITION

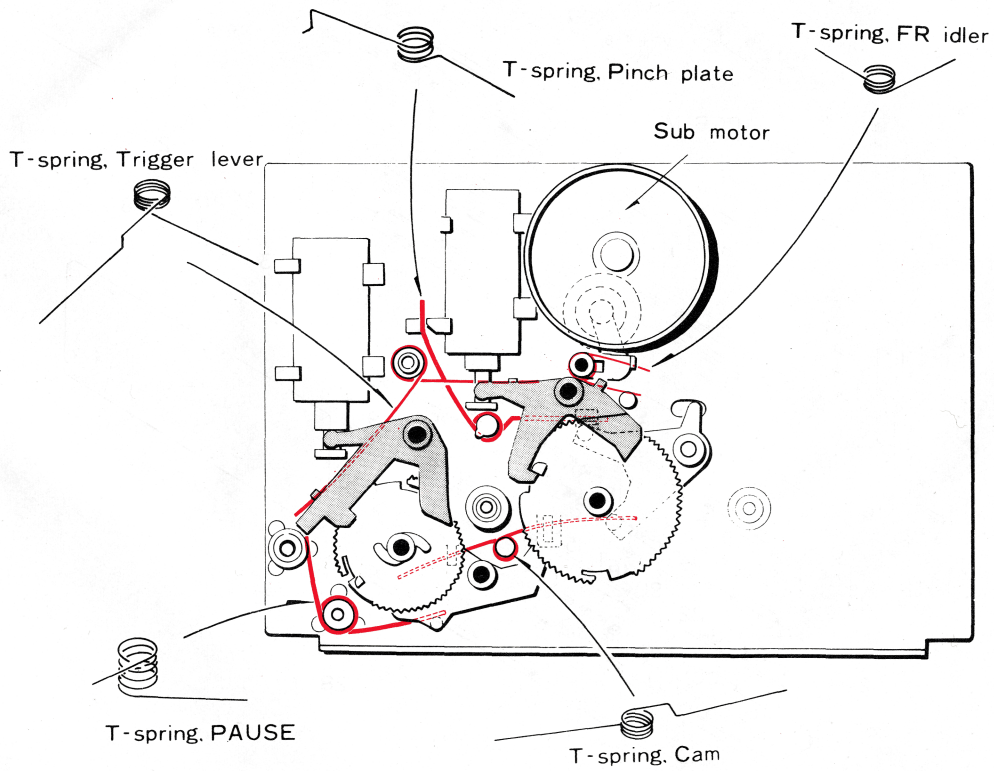
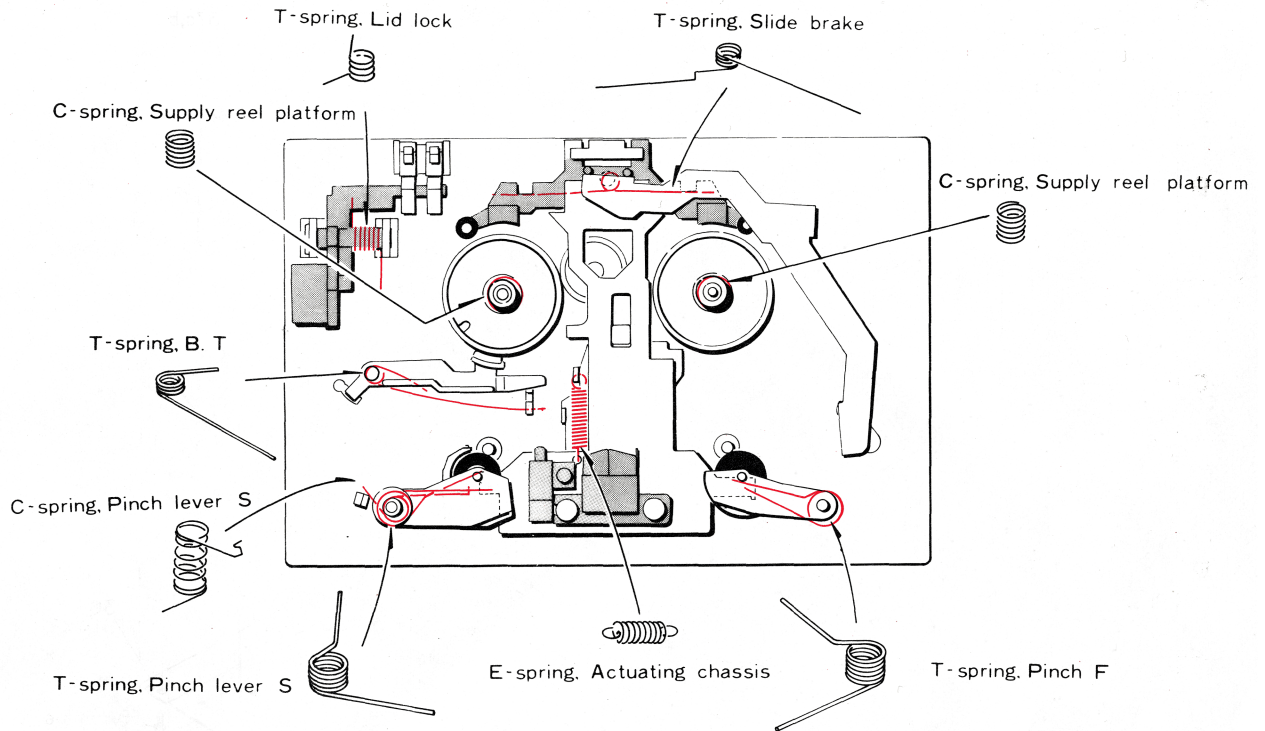

EXPLODED VIEW - I

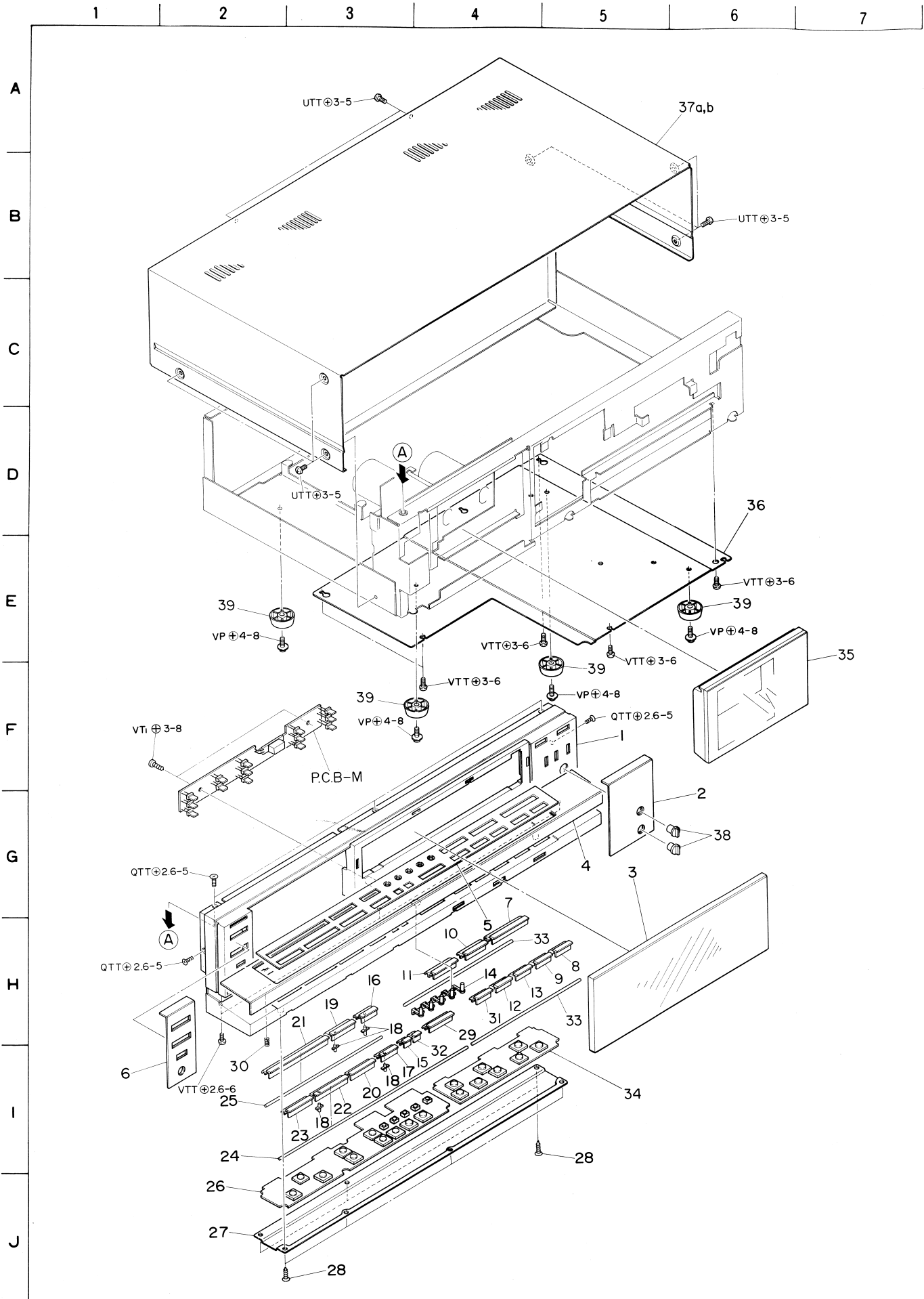

PARTS LIST

MECHANICAL PARTS

■ * mark in this part list shows exclusive part

Ref. No.	Part No.	Part No. Changed to	Description	Common Model	Q'ty
1 ~ 34	82-188-055-01		Front cabinet ass'y	*	1
1-1	— — — —		Cabinet, Front	*	1
1-2	82-188-054-01		Panel, Front	*	1
1-3	82-188-053-01		Window, Meter	*	1
1-4	82-188-046-01		Panel, Control	*	1
1-5	82-188-052-01		Panel, Control	*	1
1-6	82-188-003-01		Panel, L, Front	*	1
1-7	82-188-024-01		Touch-key, Auto VR	*	1
1-8	82-188-025-01		Touch-key, UP	*	1
1-9	82-188-026-01		Touch-key, DOWN	*	1
1-10	82-188-027-01		Touch-key, DA	*	1
1-11	82-188-028-01		Touch-key, DM	*	1
1-12	82-188-029-01		Touch-key, DOLBY B	*	1
1-13	82-188-030-01		Touch-key, DOLBY C	*	1
1-14	82-188-034-11		Touch-key, Counter	*	1
1-15	82-188-045-11		Touch-key, MS	*	1
1-16	82-188-020-01		Touch-key, REC MUTE	*	1
1-17	82-188-019-01		Touch-key, REC	*	1
1-18	82-188-037-01		Guide, Light	*	4
1-19	82-188-022-01		Touch-key, PAUSE	*	1
1-20	82-188-017-01		Touch-key, FF	*	1
1-21	82-188-021-01		Touch-key, STOP	*	1
1-22	82-188-016-01		Touch-key, PLAY	*	1
1-23	82-188-018-01		Touch-key, REW	*	1
1-24	82-188-223-01		Shaft A, Touch-key	*	1
1-25	82-188-224-01		Shaft B, Touch-key	*	1
1-26	— — — —		Control key ass'y	*	1
1-27	82-188-033-01		Cabinet A, Bottom	*	1
1-28	87-326-073-01		QT ₁ + 2.6-6		7
1-29	82-188-023-01		Touch-key, CB	*	1
1-30	82-190-215-01		C-spring, Earth	AD-F660	1
1-31	82-188-031-01		Touch-key, DOLBY OFF	*	1
1-32	82-188-038-01		Touch-key, SOURCE	*	1
1-33	82-188-225-01		Shaft C, Touch-key	*	2
1-34	— — — —		Printed circuit board B ass'y	*	1
1-35	82-188-047-01		Cassette window ass'y	*	1
1-36	82-188-056-01		Cabinet, Bottom	*	1
1-37a	82-191-027-01		Cabinet, Steel (H, HU models only)	AD-F770	1
b	82-188-057-01		Cabinet, Steel (E, K, G models only)	*	1
1-38	82-184-034-01		Knob	FX-100	2
1-39	87-085-161-01		Foot		4

EXPLODED VIEW-2

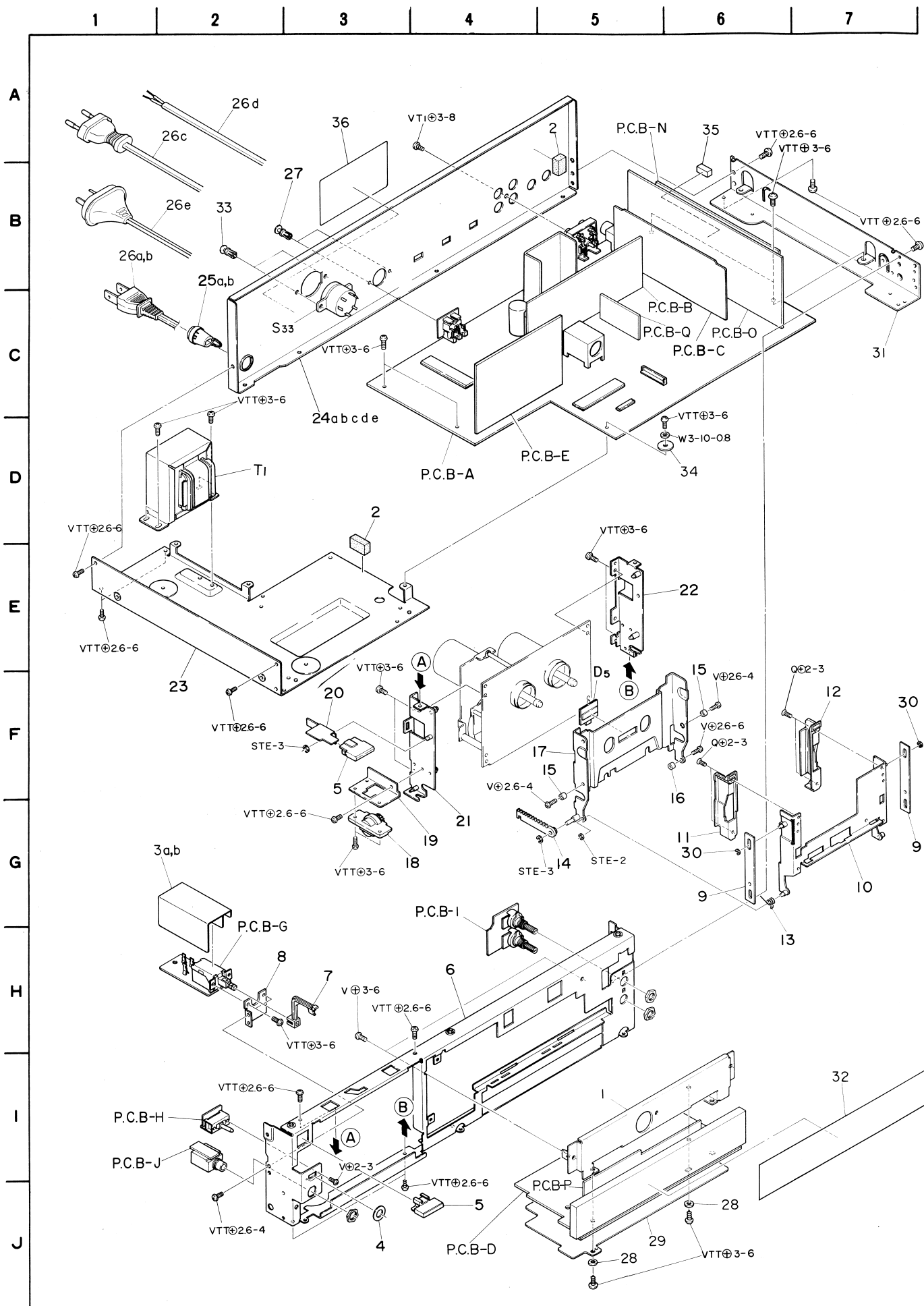

Ref. No.	Part No.	Part No. Changed to	Description	Common Model	Q'ty
2-1	82-188-218-01		FL holder	*	1
2-2	82-190-213-01		G cushion	AD-F660	2
2-3a	82-190-211-11		Cover, Power	AD-F660	1
b	82-190-217-01		Cover, Power	AD-F660	1
2-4	82-422-073-11		Himeron cloth, Blind		1
2-5	82-188-012-01		Push-button, Power	*	2
2-6	82-188-201-01		Front chassis	*	1
2-7	82-757-210-01		Rod	ST-R10	1
2-8	82-162-215-01		Holder, POWER	AD-R500	1
2-9	82-188-210-21		Lever, Cassette box	*	2
2-10	82-188-205-21		Cassette box ass'y	*	1
2-11	82-188-219-01		Holder L, Cassette	*	1
2-12	82-188-220-01		Holder R, Cassette	*	1
2-13	82-188-233-11		T-spring, OPEN	*	1
2-14	82-541-240-11		Lever, Oil-damp		1
2-15	82-188-229-01		Collar, Cassette box lever L	*	2
2-16	82-188-232-01		Collar, Cassette box lever R	*	1
2-17	82-188-039-11		Cassette plate ass'y	*	1
2-18	82-179-228-01		Oil-damper	AD-3800	1
2-19	82-188-211-01		Holder, Oil damp	*	1
2-20	82-188-212-11		Eject slide plate	*	1
2-21	82-188-213-41		Mechanism holder L ass'y	*	1
2-22	82-188-214-21		Mechanism holder R ass'y	*	1
2-23	82-188-204-01		Chassis L, Amp.	*	1
2-24a	82-188-040-01		Panel, Rear (H, HU models only)	*	1
b	82-188-041-01		Panel, Rear (U model only)	*	1
c	82-188-042-01		Panel, Rear (E model only)	*	1
d	82-188-043-01		Panel, Rear (K model only)	*	1
e	82-188-044-01		Panel, Rear (G model only)	*	1
2-25a	87-085-184-01		Cord bushing (H, HU, U models only)		1
b	87-085-185-01		Cord bushing (E, K, G models only)		1
2-26a	87-034-958-01		AC power cord (H, HU models only)		1
b	87-034-578-01		AC power cord (U model only)		1
c	87-034-877-01		AC power cord (E model only)		1
d	87-034-975-01		AC power cord (K model only)		1
e	87-034-892-01		AC power cord (G model only)		1
2-27	87-084-078-01		Nylon rivet 3-4.5		2
2-28	82-191-203-01		Spacer FL	AD-F770	2
2-29	82-188-239-01		FL shield sheet	*	1
2-30	82-190-206-01		STE-2 (Black)	AD-F660	2
2-31	82-188-209-01		Shassis R, Amp.	*	1
2-32	82-191-204-01		Filter	AD-F770	1
2-33	87-085-090-01		Nylon rivet (H, HU models only)		2
2-34	82-140-216-01		G cushion 4-16-2.5		1
2-35	82-756-657-01		Cushion U		1
2-36	82-188-049-01		Name plate, Spec. (U model only)	*	1

EXPLODED VIEW-3

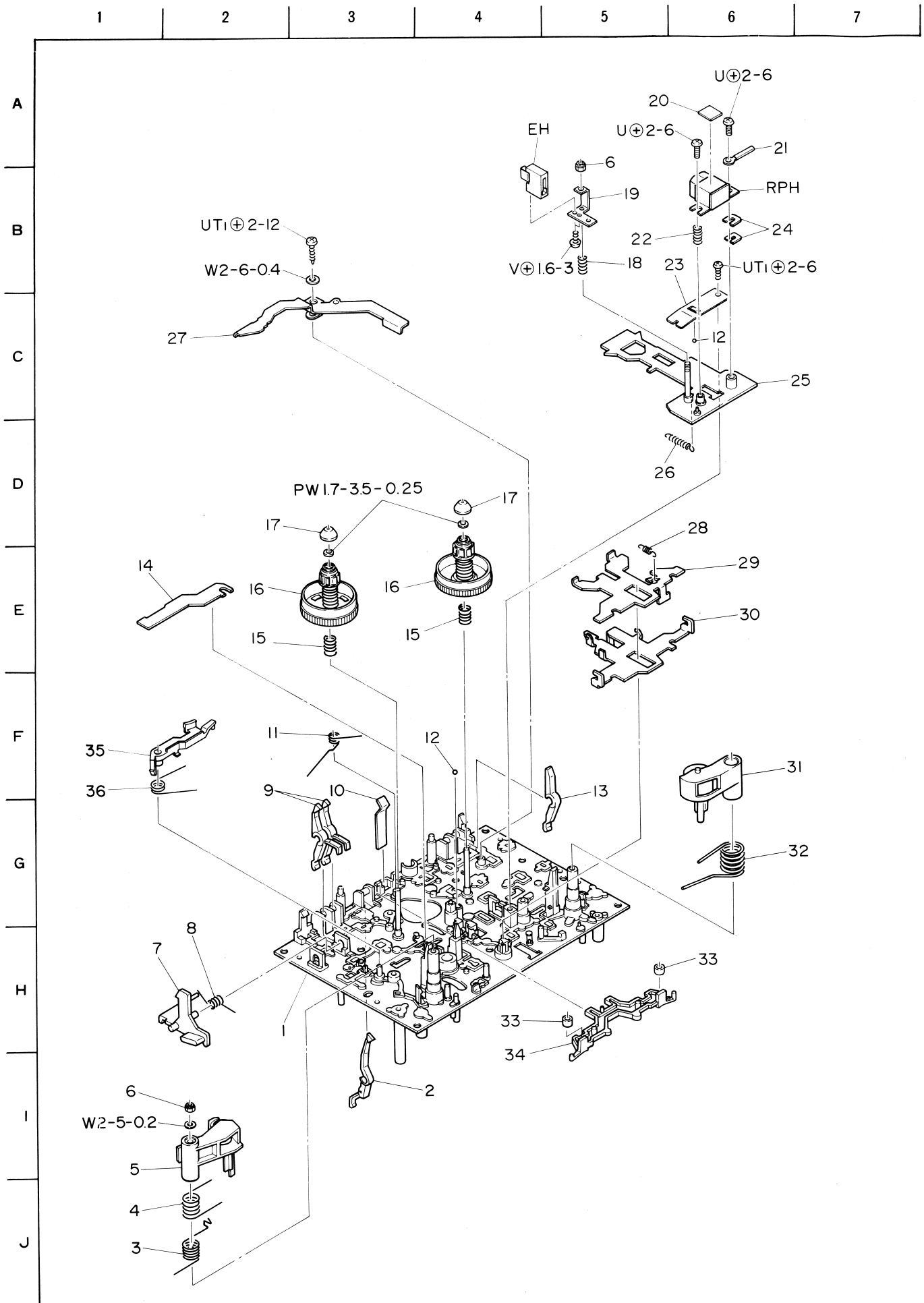

Ref. No.	Part No.	Parts No. Changed to	Description	Common Model	Q'ty
3-1	81-507-201-21		Outsert chassis ass'y		1
3-2	81-505-242-11		Lever, Metal		1
3-3	81-507-228-01		C-sprng, Pinch lever S		1
3-4	81-507-217-11		T-spring, Pinch lever S		1
3-5	81-507-207-11		Pinch lever S ass'y		1
3-6	87-081-963-01		Nylon nut M2-3.5		2
3-7	81-505-239-01		Lever, Eject		1
3-8	81-505-273-01		T-spring, Lid lock		1
3-9	81-505-241-21		REC blocking lever		2
3-10	81-505-260-01		P-spring, Pressure cassette		1
3-11	81-505-268-01		T-spring, Slide brake		1
3-12	87-073-005-01		Steel ball 2φ		2
3-13	81-505-240-21		Lever, Cassette sensor		1
3-14	81-505-238-01		Blocking plate, EJECT		1
3-15	81-507-219-01		C-spring, Supply reel platform		2
3-16	81-505-226-11		Take-up reel platform ass'y		2
3-17	82-303-398-01		Cap, Take-up reel platform		2
3-18	82-565-360-01		C-spring, EH		1
3-19	81-507-215-01		Holder, EH		1
3-20	82-188-051-01		Label, Head	*	1
3-21	87-038-056-01		Wire binder		1
3-22	82-307-212-01		C-spring, EH		1
3-23	81-507-224-01		P-spring, Actuating chassis		1
3-24	81-507-227-01		Spacer		2
3-25	81-507-214-21		Actuating chassis ass'y		1
3-26	81-505-265-11		E-spring, Actuating chassis		1
3-27	81-505-307-01		Lever, Brake eject		1
3-28	81-505-266-01		E-spring, APUSE plate		1
3-29	81-505-207-01		Plate, PAUSE		1
3-30	81-507-220-01		Plate, Pinch lever		1
3-31	81-505-210-11		Pinch lever F ass'y		1
3-32	81-505-267-01		T-spring, Pinch F		1
3-33	81-507-229-01		G brake		2
3-34	81-505-236-11		Lever, Slide brake		1
3-35	81-507-222-01		Lever, Back tension		1
3-36	81-507-223-01		T-spring, B.T		1

EXPLODED VIEW - 4

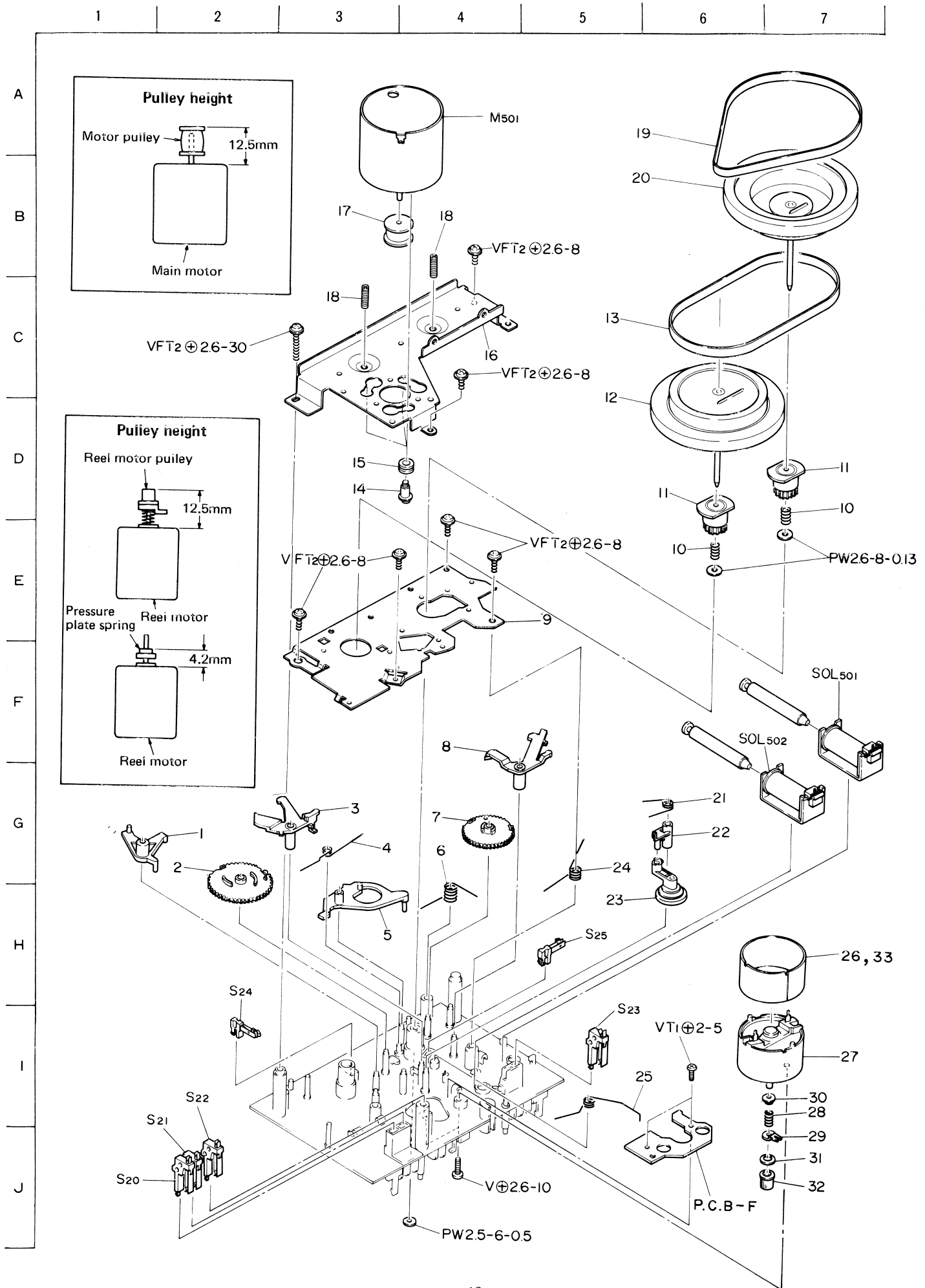

Ref. No.	Part No.	Parts No. Changed to	Description	Common Model	Q'ty
4-1	81-505-230-01		Lever, PLAY		1
4-2	81-505-234-01		Gear, PLAY cam		1
4-3	81-505-231-01		Trigger lever, PLAY		1
4-4	81-505-272-01		T-spring, Cam		1
4-5	81-505-308-01		Lever B, PAUSE		1
4-6	81-505-283-01		T-spring, PAUSE lever		1
4-7	81-505-235-01		Gear, PAUSE cam		1
4-8	81-505-233-01		Trigger lever, PAUSE		1
4-9	81-505-204-01		Chassis B, Mechanism		1
4-10	81-505-261-01		C-spring, Flywheel F		2
4-11	81-505-225-01		Gear, Flywheel		2
4-12	81-507-205-01		Flywheel S ass'y		1
4-13	81-507-225-01		Rubber belt B		1
4-14	87-081-483-01		Motor screw, M2.6		3
4-15	87-087-029-01		Rubber cushion		3
4-16	81-507-221-01		Holder, Motor		1
4-17	81-505-245-01		Motor pulley 2-10-6.8		1
4-18	82-565-373-01		Screw, Thrust		2
4-19	81-507-216-01		Rubber belt A		1
4-20	81-507-238-01		Flywheel T ass'y		1
4-21	81-505-282-01		T-spring, FR idler		1
4-22	81-505-254-01		Lever A, FR idler		1
4-23	81-507-231-11		FR idler ass'y		1
4-24	81-505-271-01		T-spring, Trigger lever		1
4-25	81-505-269-01		T-spring, Pinch plate		1
26~33	09-011-038-01		Reel motor ass'y		1
4-26	81-505-606-01		Shield plate		1
4-27	81-505-604-11		Motor, Reel		1
4-28	81-505-290-01		C-spring, FR idler C		1
4-29	81-505-287-11		Lever C, FR idler		1
4-30	81-505-289-01		Pressure plate spring		1
4-31	81-505-292-11		Felt 4.5-7.2-0.8		1
4-32	81-505-320-01		Pulley, Reel motor		1
4-33	81-505-608-01		Shield plate B		1

Part No.	Description
87-081-954-01	V+1.6-3
87-081-217-01	V+2-3
87-081-305-01	V+2.6-4
87-267-073-11	V+2.6-6
87-261-075-21	V+2.6-10
87-161-094-21	V+3-6
87-351-034-21	VT ₁ +2-5
87-356-095-01	VT ₁ +3-8
87-081-501-01	VTT+2.6-4
87-081-475-01	VTT+2.6-6

Part No.	Description
87-081-511-01	VTT+3-6
87-251-035-21	U+2-6
87-341-035-21	UT ₁ +2-6
87-341-038-21	UT ₁ +2-12
87-081-919-01	UTT+3-5
87-231-032-21	Q+2-3
87-081-521-01	QTT+2.6-5
87-512-074-01	VFT ₂ +2.6-8
81-505-229-01	VFT ₂ +2.6-30
87-521-170-21	VP+4-8

DESCRIPTION OF MICROCOMPUTER TERMINAL

Description of microcomputer terminal-1

Terminal name IC-1

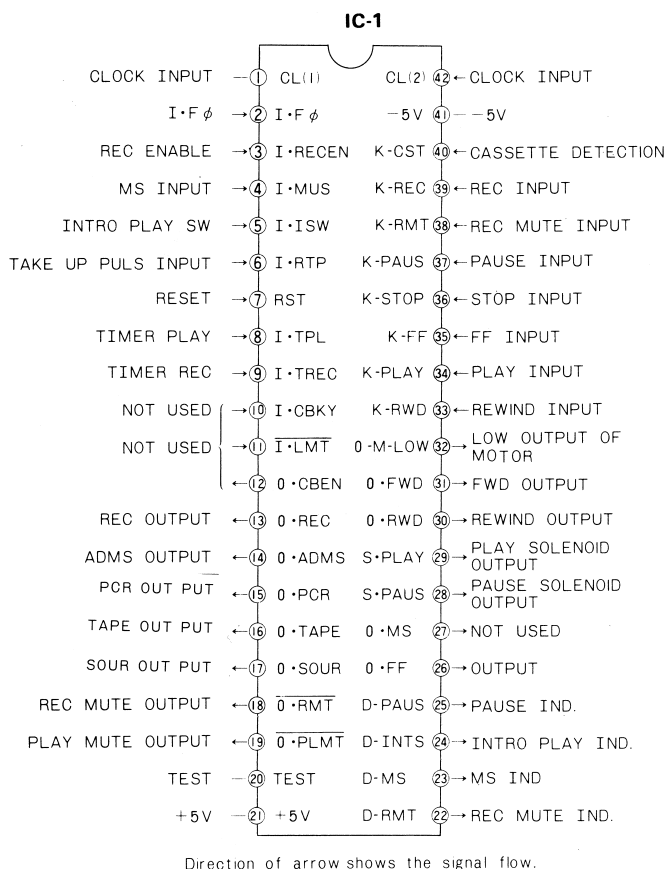

Terminal functions

"H": High level, 5V "L": Low level, 0 or -5V [μPD546C-357]

Pin No.	Terminal symbol	Function
① ④②	CL (1) CL (2)	The clock receives only 400 kHz
②	I·Fφ	Terminal to inhibit ME.RWD during REC. Set to "L" from "H" when the RWD command is input from the microcomputer.
③	I·RECEN	The terminal is set to "L" and recording is not done when the safety tab is broken off.
④	I·MUS	Signal input during INTRO PLAY and MS. Set to "H" for tunes and to "L" between tunes.
⑤	I·ISW	Switch to select the INTRO PLAY and MS. Repeats OFF → INTRO PLAY → MS → OFF.
⑥	I·RTP	Inputs the pulse from the takeup reel disk sensor. For AUTOSTOP.

Pin No.	Terminal symbol	Function
⑦	RST	RESET terminal. Set to "H" instantaneously when power is switched ON; also set to "H" instantaneously when power is switched OFF. Set to "L" in general.
⑧	T·PL	Set to "H" during timer play and recording. Set to "L" during OFF.
⑨	T·REC	
⑩	I·CBKY	KEY REQUEST from the compu-brain. The REC/PLAY, FF and REW keys can be accepted when this pin is set to Hi.
⑪	I·LMT	Input from the compu-brain. Set to Hi during the compu-brain mode. Reads the counter during compu-brain operation.
⑫	0·CBEN	Outputs Hi when the compu-brain operation is possible (when the mechanism is in the STOP mode and recording is possible).
⑬	0·REC	Set to "H" during recording. For erase, bias oscillator.
⑭	0·ADMS	Set to "H" for approx. 1.5 sec during power ON. For ADMS.
⑮	0·RCR	Set to "H" during PLAY, CUE, REV.
⑯	0·TAPE	Set to "H" during REC/PLAY, PLAY, CUE, REV.
⑰	0·SOUR	Set to "H" during REC, REC/PLAY/PAUSE.
⑱	0·RMT	Set to "H" during recording, and "L" during REC-MUTE in recording.
⑲	0·PLMT	Set to "H" during REC/PLAY, CUE/REV to release muting. Set to "L" during INTRO PLAY, MS.
⑳	TEST	Connect to +5V.
㉒ ~ ㉕	D-...	Indication output. Set to "H" during operation.
㉖	0-FF	Set to "H" during FF, CUE.
㉘	S-PAUS	Set to "H" during PAUSE, FF/REW CUE/REV.
㉙	S-PLAY	Set to "H" during PLAY/REC, CUE/REV.
⑳	0-RWD	Set to "H" during RWD/REV.
㉑	0-FWD	Set to "H" during REC/PLAY/FF/CUE.
㉒	0-M-LOW	Set to "H" during PLAY, REC/PLAY.
㉓ ~ ㉔	K-...	Key input. Set to "H" in general. Accepts key input when changed to "L" from "H"

Description of microcomputer terminal-2

Terminal name IC-2

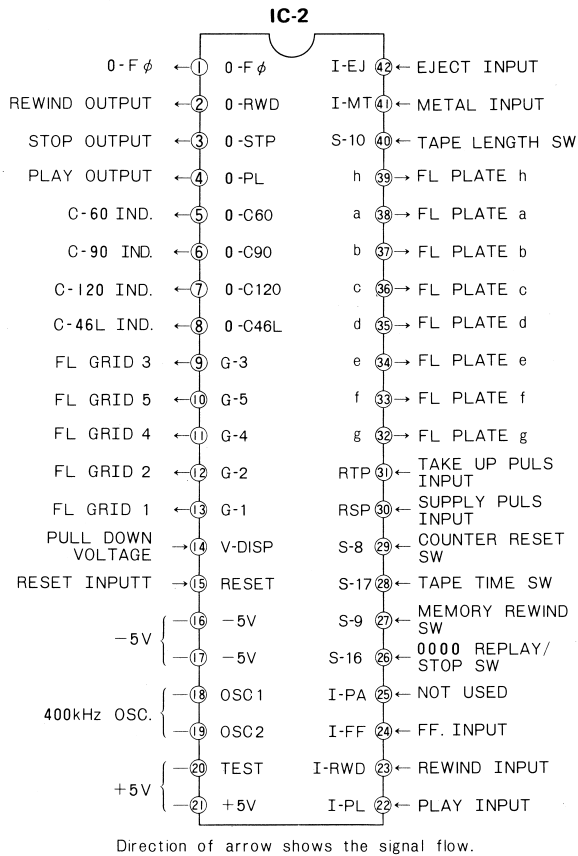

Terminal functions

"H": High level, +5 "L": Low level, 0 or -5V

Pin No.	Terminal symbol	Function
①	0-F ϕ	This is set to "L" in general and to "H" when 0-RWD, 0-STOP or 0-PL is output. This is used to discriminate between the key inputs of the mechanism controller.
②	0-RWD	"L" is output to perform memory-RWD in the counter mode. Set to "H" in general.
③	0-STP	"L" is output to perform 0000 STOP in the counter mode. Set to "H" in general.
④	0-PL	"L" is output to perform 0000 REPLAY in the counter mode. Set to "H" in general.
⑤ ~ ⑧	0-C...	This is used for TAPE LENGTH indication.
⑨ ~ ⑬	G...	Connected to the FL grid.
⑭	V-DISP	This terminal determines the internal pull-down potential.
⑮	RESET	Internal reset is possible. Reset is applied when this is connected to -5V.

Pin No.	Terminal symbol	Function
⑯, ⑰	-5V	-5V
⑱, ⑲	OSC	This is 400 kHz ceramic oscillator.
⑳, ㉑	+5V	+5V
㉒	I-PL	"H" is input during play, record/play and the remaining minutes and seconds are calculated.
㉓	I-RWD	"H" is input during RWD, and the remaining tape in the RWD direction is calculated.
㉔	I-FF	"H" is input during FF and the remaining tape in the FF direction is calculated.
㉖ ~ ㉙ ④①	S-...	Counter function input switch. Set to "L" in general, and "H" is input when the key is set to ON.
③①	RSP	Inputs the pulse output from the supply reel disk. This is used to measure the time it takes the supply reel disk to complete 1 revolution during play.
③①	RTP	Inputs the pulse output from the take-up reel. This is used for the counter.
③② ~ ③④	a ~ h	Connected to the FL plate.
④①	I-MT	Set to "L" in general and to "H" when METAL TAPE is used. The remaining tape is corrected for the thickness of METAL TAPE.
④②	I-EJ	This is used to reset the counter to "0000" when the cassette is not inserted during the counter mode. The remaining amount is erased during EJECT in the remaining tape mode.

Description of microcomputer terminal-3

Terminal name IC-3

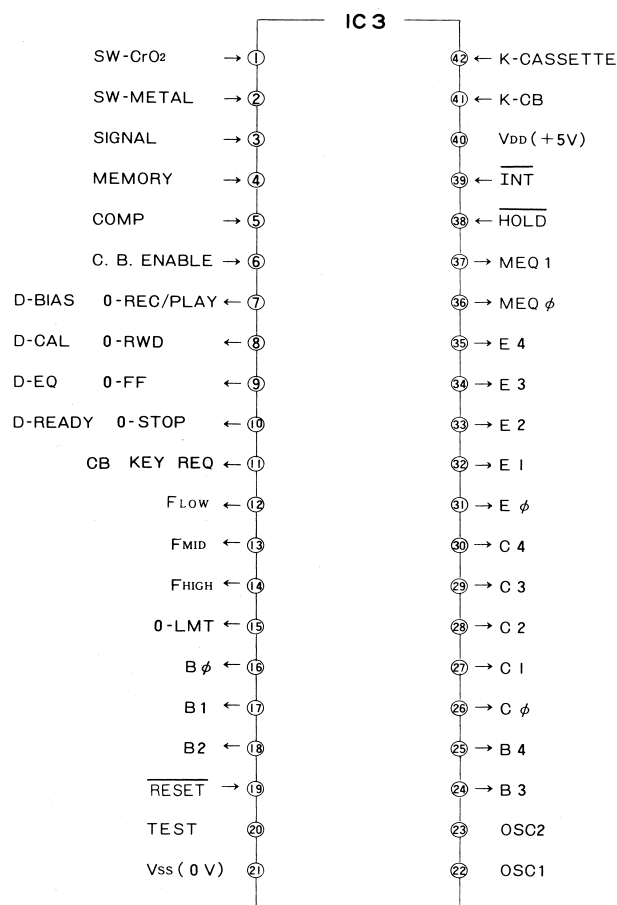

INPUT : K-CB "L" START/RESET
 K-CASSETTE "H" CASSETT ON
 SIGNAL "L" Magnetic coating provided
 C.B.ENABLE "H" C.B. START possible
 MEMORY "H" BACK UP ON

OUTPUT : FRTS KEY REQ. KEY REQ from "H" FRTS
 MEQ φ BIAS DATA φ φ φ φ φ "H"
 MEQ I " I I I I I "H"



Terminal functions

"H": High level 5V, "L": Low level "0V" LC6505C-609

Pin No.	Pin mark	Function
①	SW-Cr	Tape selector logic input
②	SW-MT	WRITE/READ of the compu-brain data to/from memory
③	SIGNAL	Record/Play signal input during the compu-brain adjustment. (Detects the magnetic coating.) "L" shows that the magnetic coating is present.

Pin No.	Pin mark	Function
④	MEMORY	Detects presence/absence of back-up operation. Back-up is present when this pin is set to Hi: Call of compu-brain adjusted data (memory data). Back-up is not present when this pin is set to Lo: Call-up of standard data.
⑤	COMP	Comparison result input during compu-brain adjustment
⑥	CB-EN	Detects possibility of compu-brain. START is possible when this pin is set to Hi.
⑦	D-BIAS/ O-REC/PLAY	Pin 11 is set to Hi and REC/PB key is pressed with pin 7 set to Hi. Bias LED is lit when pin 11 is set to Lo.
⑧	C-CAL/ O-REW	Pin 11 is set to Hi and REW key is pressed when pin 8 is set to Hi. CAL LED is lit when pin 11 is set to Lo.
⑨	D-EQ/O-FF	Pin 11 is set to Hi and FF key is pressed when pin 9 is set to Hi. EQ LED is lit when pin 11 is set to Lo.
⑩	D-READY/ O-STOP	Pin 11 is set to Hi and STOP key is pressed when pin 10 is set to Hi. READY LED is lit when pin 11 is set to Lo.
⑪	KEY REQ	When this pin is set to Hi, the mechanism key is requested from the compu-brain.
⑫	OSL FL	Controls the test tone 400 Hz used during compu-brain.
⑬	OSL FM	Controls the test tone 10 kHz used during compu-brain.
⑭	OSC FH	Controls the test tone 13 kHz used during compu-brain.
⑮	O-LMT	LINE MUTE output. Hi output in general. MUTE on when this output is set to Lo. Set to Lo for approx. 2.5 sec during compu-brain or after power is set to ON.
⑯	Bφ	Compu-brain data output BIAS φ: Set to Hi when 2 ⁰ bit is set.
⑰	B1	Compu-brain data output BIAS 1: Set to Hi when 2 ¹ bit is set.
⑱	B2	Compu-brain data output BIAS 2: Set to Hi when 2 ² bit is set.
⑳	B3	Compu-brain data output BIAS 3: Set to Hi when 2 ³ bit is set.
㉑	B4	Compu-brain data output BIAS 4: Set to Hi when 2 ⁴ bit is set.
⑲	RESET	Reset pin input
⑳	TEST	Connected to the 0V power supply
㉑	Vss	

Pin No.	Pin mark	Function
22	OSC1	This pin supplies external operation clock. Inputs the mechanism control 400 Hz.
23	OSC2	Internal clock oscillating pin attached to the external resonance circuit. Not connected.
26	C ϕ	Compu-brain data output CAL ϕ : Set to Hi when 2 ⁰ bit is set.
27	C1	Compu-brain data output CAL 1: Set to Hi when 2 ¹ bit is set.
28	C2	Compu-brain data output CAL 2: Set to Hi when 2 ² bit is set.
29	C3	Compu-brain data output CAL 3: Set to Hi when 2 ³ bit is set.
30	C4	Compu brain data output CAL 4: Set to Hi when 2 ⁴ bit is set.
31	E ϕ	Compu-brain data output EQ ϕ : Set to Hi when 2 ⁰ bit is set.
32	E1	Compu-brain data output EQ 1: Set to Hi when 2 ¹ bit is set.
33	E2	Compu-brain data output EQ 2: Set to Hi when 2 ² bit is set.
34	E3	Compu-brain data output EQ 3: Set to Hi when 2 ³ bit is set:
35	E4	Compu-brain data output EQ 4: Set to Hi when 2 ⁴ bit is set.
36	MEQ ϕ	Set to Hi when B0, B1, B2, B3, B4 of the data are set to $\phi\phi\phi\phi$ during bias adjustment. To change recording equalizer.
37	MEQ1	Set to Hi when B0, B1, B2, B3, B4 of the data are set to 11111 during bias adjustment. To change recording equalizer.
38	HOLD	HOLD mode demand input pin.
39	INT	Interruption demand input pin. Not connected.
40	VDD	Power pin. Connected to the back-up capacitor circuit. Approx. 5.3V in general. Approx. 5.6V just after power OFF, and then gradually drops in several hours.
41	K-CB	Compu-brain key. Compu-brain start/reset when this is set to Lo.
42	K-CST	For cassette detection. Set to Hi when a cassette is present.

AD-F990 Block diagram

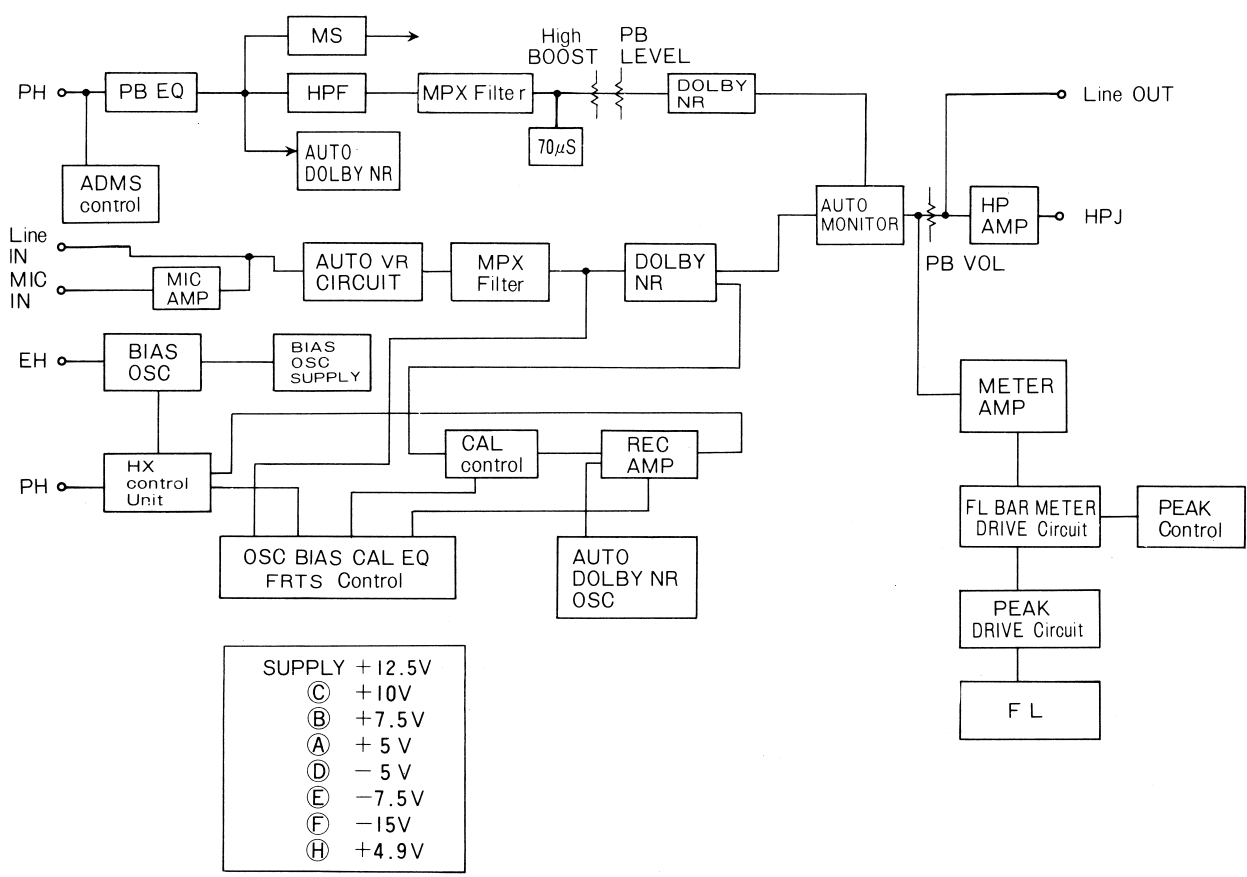

Circuit description

1. AUTO DOLBY-NR selector system

Outline

The auto Dolby-NR selector system selects the NR position automatically when playing back tapes recorded using this unit.

System

An ultra-low frequency signal (Table 1) is recorded simultaneously when the source signal is recorded on the tape by selecting the DOLBY-NR "AUTO" and then selecting DOLBY-NR "B-TYPE" or "C-TYPE" when recording with this unit.

The presence/absence and type of ultra-low frequency signal are detected during play to determine the NR position.

AUTO	Lch	Rch
OFF	No connect	No connect
B	7 Hz	9 Hz
C	9 Hz	7 Hz

MANUAL	Lch	Rch
OFF, B, C	No connect	No connect

Block diagram

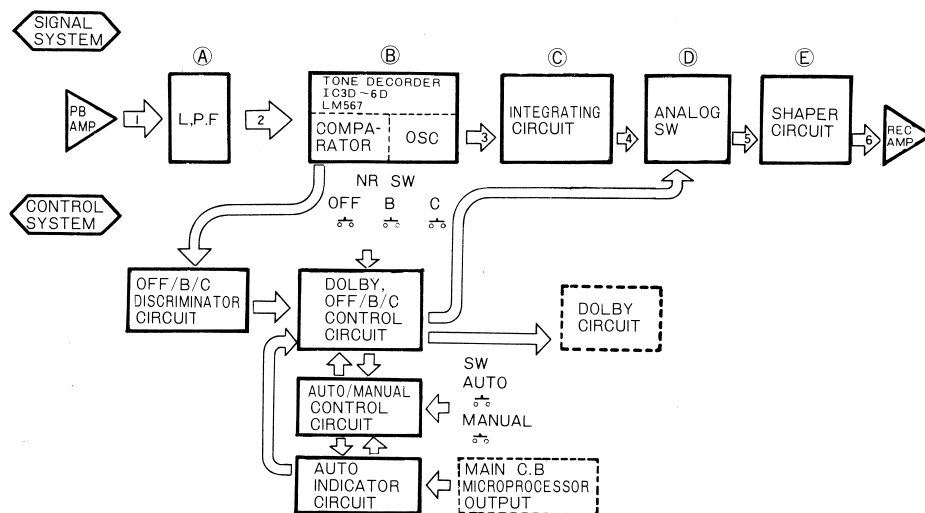

1-1. Description of each block

(A) L.P.F.

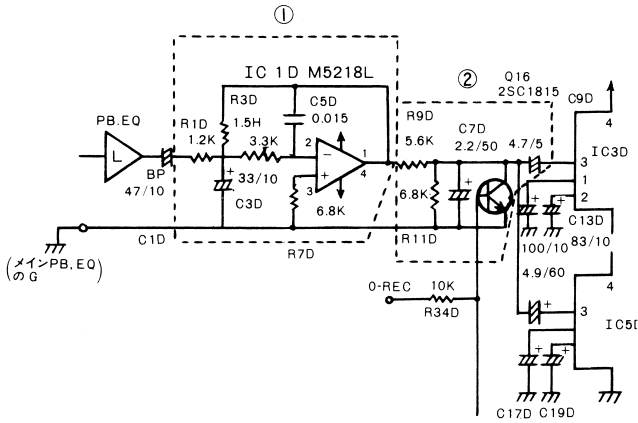

- ① Active filter $f_0 = 2.7\text{Hz}$ $Q = 0.69$
- ② CR filter $f_0 = 8.02\text{Hz}$ $Q = 0.278$
- i) The play signal is not input to IC3D, 5D pin 3 with 0-Rec = "H" during recording.
- ii) The outputs during playback are: 7 Hz (-15 dBV), 9 Hz (-17 dBV) at IC1D pin 1, and 7 Hz (-23 dBV), 9 Hz (-23 dBV) at IC3D, IC5D pin 3.
(Note: Measuring instrument = RIKEN FET, CF-300)

(B) Tone, decoder IC3D, 5D

(C) Integrating circuit
Block diagram IC3D, 5D LM567

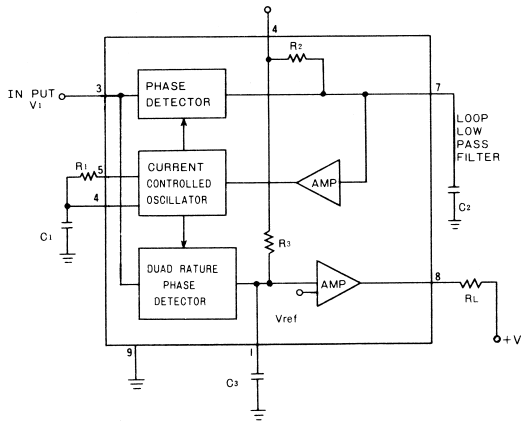

- ① C3D, 5D (pin 3) : Signal inputs
- ② IC3D, 5D (pin 1)C: Externally attached filter
- ③ IC3D, 5D (pin 2)C: Externally attached filter
- ④ IC3D, 5D (pin 8) are output as shown below when the relation between input f and f' of the built-in OSC is as shown below.
 $f = f'$ "L"
 $f \neq f'$ "H"
- ⑤ The oscillation frequency is determined by (R, SFR, C) from IC3D, 5D (pin 5).
- ⑥ Integrated as via IC6D (FET input OP amp).
- ⑦ Another output of the IC3D, 5D (pin 5) is connected to the AUTO indicator circuit and used to flash the AUTO indicator LED.

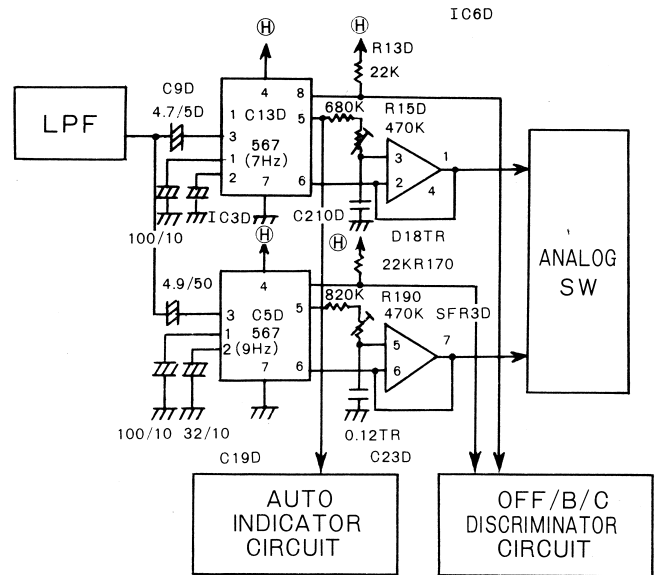

(D) Analog SW

① Analog SW IC8D

AUTO	(Pin 2,3)	(Pin 9,10)
OFF	No signal	No signal
B	7 Hz	9 Hz
C	9 Hz	7 Hz

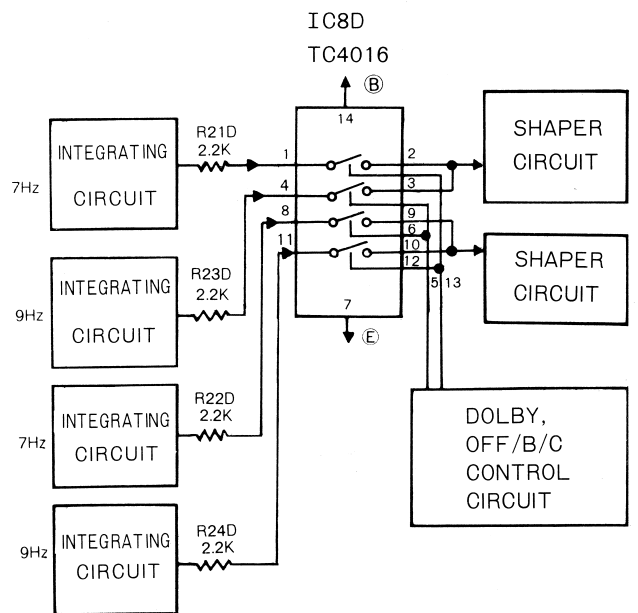

E Shaper circuit

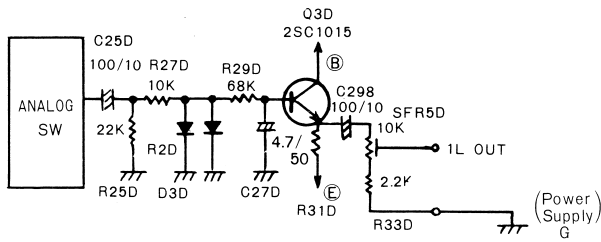

- 1) The analog SW/output signal (integrating waveform) is converted to a sine wave. Q3D is an emitter-follower.

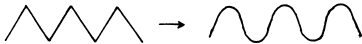

- 2) The output of the shaper circuit is input to the record amp of the main C.B.
- 3) The ultra-low frequency signal recording level is set to the level so that -26 dB can be obtained at TTA161 as tape playback level.

1-2. Dolby NR circuit NR control

The NR control is controlled by the circuit shown below.

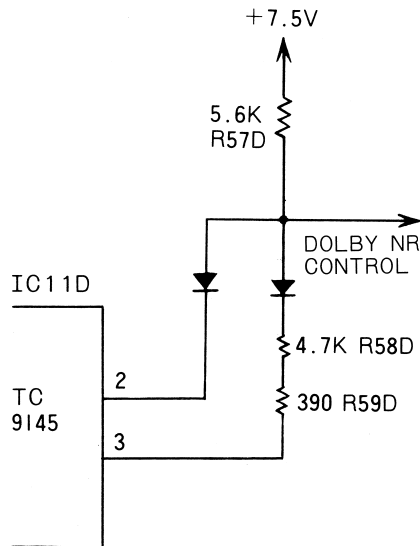

Dolby-NR: IC11D, pin 2 is set to -7.5 V when the Dolby-NR circuit is set to OFF and the NR control is set to approx. -7 V.

Dolby-NR: IC11D, pin 3 is set to approx. -7.5 V when the Dolby-NR circuit is set to "B-TYPE", and the NR control is set to approx. $+0.6$ V.

Dolby-NR: The Dolby-NR control is set to approx. 2 V when the Dolby-NR circuit is set to "C-TYPE" via R570.

1-3. Description of operation

(1) During recording

1) Auto Dolby-NR B-type

- i) ① (IC14D1/2, pin 7) is set to "H" when the auto SW is set to ON, and ②, "H", ③, "L".
- ii) ②⑥ (IC11D pin 14) is set to "H" with the Dolby-NR SW B-type set to ON, and ③④, "L". The Dolby-NR LED is lit with ③④ set to "L".
- iii) ③ and ④ are set to "L", ③⑧, "H" and IC8D pins 13, 12 "H". By this, IC8D pins 1 and 2, pins 11 and 12 are activated, and 7 Hz is output to the Lch OUT and 9 Hz, to the Rch OUT.
- iv) AUTO LED is: ⑥ (0-PCR) is set to "L", ⑦, "H", ⑧, "L" and ②, "H", so ⑨ is set to "L", and when ⑨ is set to "L", ⑬ is set to "L" regardless of ⑪, and Q9D emitter is set to "L" and ⑩ (collector) to "L", at the same time, ③ is set to "L", so ③① is set to "L", and Q10D is set to ON and is lit.

2) Auto Dolby-NR C-type

- i) Same as B-type i).
- ii) ②⑦ is set to "H" and ③⑤, "L" with the Dolby-NR SW C-type set to ON. The Dolby-NR LED is lit when ③⑤ is set to "L".
- iii) ③ and ④ are set to "L", ③⑧, "H" and IC8D pin 5, pin 6 are set to "H". By this, IC8D pins 4 and 3, pins 8 and 9 are activated, and 9 Hz is output to Lch OUT and 7 Hz, to Rch OUT.
- iv) Same as B-TYPE iv).

3) Manual Dolby-NR B-Type

- i) ④ is set to "H", ②, "L" and ③ to "H" when the manual SW is set to ON.
- ii) Same as Auto, B-Type ii).
- iii) ③ is set to "H", so both ③⑧, ③⑨ are set to "L" regardless of ③④, ③⑤. All the circuits of IC8D are set open, and no signal is output to Lch OUT and Rch OUT.
- iv) AUTO LED is: ③ is set to "H", so ③① is also set to "H" and Q10D is set to OFF and goes out.

4) Manual Dolby-NR C-Type

- i) Same as 3)-i).
- ii) Same as 3)-ii).
- iii) Same as 3)-iii).
- iv) Same as 3)-iv).

5) Manual Dolby-NR OFF

- i) Same as 3)-i).
- ii) ②⑧ is set to "H" and ③③ to "L" (③④ and ③⑤, "H") when the Dolby-NR SW, OFF position is selected.
- iii) Same as 3)-iii).
- iv) Same as 3)-iv).

Control system During recording

	AUTO B	AUTO C	MANUAL B	MANUAL C	MANUAL OFF
①	(\square)	(\square)	L	L	L
②	H	H	L	L	L
③	L	L	H	H	H
④	L	L	(\square)	(\square)	(\square)
⑨	L	L	L	L	L
⑩	L	L	L	L	L
⑪	L	L	L	L	L
⑫	H	H	H	H	H
⑬	L	L	L	L	L
⑯	(\square)	L	(\square)	L	L
⑰	L	(\square)	L	(\square)	L
⑱	L	L	L	L	(\square)
⑳	L	L	L	L	L
㉑	L	L	H	H	H
㉒	H	H	L	L	L
㉓	H	H	H	H	L
㉔	L	H	L	H	H
㉕	H	L	H	L	H
㉖	(\square)	(\square)	(\square)	(\square)	L
㉗	L	L	L	L	L
㉘	H	L	L	L	L
㉙	L	H	L	L	L

- i) ① AUTO (ON), ② OFF (ON): MANUAL OFF
 ii) ① OFF (ON), ② AUTO (ON): aut (OFF). However, it is the same result as MANUAL (OFF).

(2) Common AUTO operation during playback

1) Operation A

Relation between ultra-low frequency signal playback and IC3D, 5D comparator output.

	COLLATION	DOLBY - NR		
		B-TYPE	C-TYPE	OFF
Lch	⑭	L	H	H
	⑮	H	L	H
Rch	⑯	H	L	H
	⑰	L	H	H

⑱, ⑲, 20, 21 are set to ON and "H" when the bases of all transistors are set to "L", so they become the inverted outputs shown in the table below.

2) Operation B

- i) ⑤ 0-MLOW is set to "H" during REC/PB and PLAY, and ⑥ 0-PCR to "H" during PLAY, CUR and REV, and Q11D (2SC1815) base is set to "H" only during PLAY.
 ii) Q11D is set to ON and ⑦ to "L" and ⑧ to "H".
 iii) ② is set to "H" (Refer to RFC) and ③ to "L" during "AUTO" operation.
 iv) When ⑧ is set to "H", the differential waveform is generated at ⑮, and ⑪ at "H" instantaneously drops to "L" via the one-shot multi vibrator-circuit, and then set to "H" after a specified time. (approx. 4 sec)
 v) When ② is set to "H" and ⑧ to "H", ⑨ is set to "H", ⑬ works the same as ⑪ under this condition.

3) Operation C

- i) All the outputs of ⑳, ㉑, ㉒, ㉓, are set to "H" while ⑬ is set to "L". When ⑬ changes from "L" to "H", the inversion outputs of the ⑱ ~ ㉑ inputs are obtained at ㉒ ~ ㉓. This state is equivalent to the table of the basic AUTO operation A shown above.

	COLLATION	IC10D	B-TYPE	C-TYPE	OFF
IN-PUT	㉒	10	L	H	H
	㉑	13	H	L	H
	㉒	12	H	L	H
	㉓	11	L	H	H
OUTPUT		2	L	L	L
		1	L	L	L
		7	H	L	L
		14	L	L	L
		9	L	L	L
		5	L	H	L

(3) Operation during playback

1) Auto Dolby-NR B-type playback

- i) The IC10D output is: only pin 7 is set to "H" ⑳ to "H", ㉖ to "H", and ㉔ to "L" during the B-type operation due to (2) common operation C. By this, LED B is lit the same as in recording, and the Dolby NR control voltage is applied.
 ii) ㉔ is set to "H", ㉑ to "H" and Q9D is set to OFF and ⑳ to "L". At the same time, ③ (as shown in (2)-2-iii)) is set to "L", so ㉑ is set to "L", Q10D, ON and AUTO LED is left lit.

2) AUTO Dolby-NR C-TYPE playback

- i) Due to (2) common operation 3), the IC10D output is; only pin 5 is set to "H", and ㉑ to "H", ㉖ to "H" and ㉓ is set to "L". By this, LED C is lit the same as in recording, and the DOLBY-NR control voltage is applied.
 ii) ㉑ is set to "H" and ㉑ to "H", and thereafter, the operation is same as in (3)-i), ii).

3) Playback of tape recorded with AUTO Dolby-NR OFF and by other decks.

- i) All the IC10D outputs are set to "L" as shown in (2) common operation 3), the square wave output from IC3D is input to ㉑
 ii) The emitter is set to "H" after a certain time (4 sec) and the square wave shown in i) is input to the base, so Q9D (2SA1015) repeats ON/OFF operation. As a result, ㉑ is set to the square wave with the same period as IC3D and ㉑ is also the same, so the LED lighting Q10D (2SA1015) repeats ON/OFF and the AUTO LED flashes.
 iii) At the same time, the ㉑ output is charged by the C.R. time constant circuit for a certain time (4 sec) and then 28 is set to "H". By this it is set to OFF.

(Note) Q15 (2SC 1815) the collector of which is connected to the CR time constant circuit is set to ON in (3)-1) or in (3)-2) (㉔ or ㉑ is set to "H") to perform discharging.

During PLAY

	AUTO B Signal (L:7Hz, R:9Hz)	AUTO C Signal (L:9Hz, R:7Hz)	AUTO OFF (NO Signal)
①	(\square)	(\square)	(\square)
②	H	H	H
③	L	L	L
④	L	L	$\overline{\square}$
⑤	H	H	H
⑥	H	H	H
⑦	L	L	L
⑧	H	H	H
⑨	H	L	L
⑩	$\overline{\square}$	$\overline{\square}$	$\overline{\square}$
⑪	$\overline{\square}$ 4 sec	$\overline{\square}$	$\overline{\square}$
⑫	$\overline{\square}$	$\overline{\square}$	$\overline{\square}$
⑬	$\overline{\square}$	$\overline{\square}$	$\overline{\square}$
⑭	L	H	H
⑮	H	L	H
⑯	H	L	H
⑰	L	H	H
⑱	H	L	L
⑲	L	H	L
⑳	L	H	L
㉑	H	L	L
㉒	L	H	H
㉓	H	L	H
㉔	H	L	H
㉕	L	H	H
㉖	H	L	L
㉗	L	H	L
㉘	L	L	$\overline{\square}$
㉙	H	H	\square (7Hz)
㉚	L	L	\square (7Hz)
㉛	L	L	\square (7Hz)
㉜	H	H	\square (7Hz)
㉝	H	H	$\overline{\square}$
㉞	L	H	H
㉟	H	L	H
㊱	H	H	L
㊲	L	L	H

2. AUTO TAPE MONITOR SYSTEM

Outline

The auto tape monitor selects the MONITOR circuit automatically to "TAPE" and "SOURCE" in accordance with the mechanism operation. This system controls the circuit so that it is selected automatically to "TAPE" during PLAY and RECORD/PLAY and to "SOURCE" during independent recording and record-pause by means of output from the microprocessor controlling the mechanism. It is possible to select to TAPE or SOURCE manually by use of the MONITOR switch on the front panel.

Block diagram

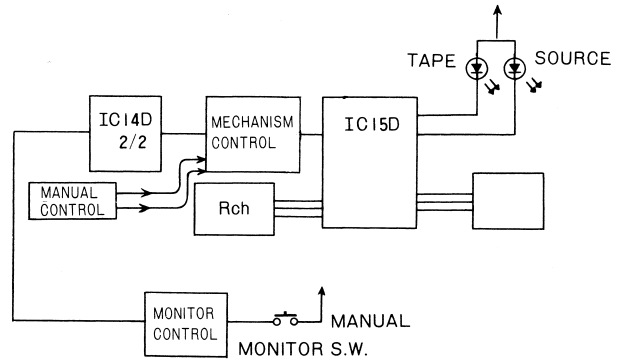

2-1 T/S selection

During power ON

- ⑤ is set to "H" until Q13D is set to ON, ⑦ is set to "H", and ⑬ is directly set to "H" via R92D, and ⑨ is set to "H", and ⑪ to "L". → TAPE POSITION
- When ④ 0-SOURCE (during REC and REC-PAUSE) is set to "H" (30m sec) via mechanism control, ⑩ is set to "H" and ⑫ to "L". → SOURCE POSITION
- When ③ 0-TAPE (during PLAY and REC/PLAY) is set to "H" (30m sec) via the mechanism control, ⑨ is set to "H" and ⑪ to "L". → TAPE POSITION
- When the manual T/S SW is set to ON, "H" at ① passes through the differential circuit, ② is set to "H", and IC14D2/2 is the circuit that when ② is changed from "L" to "H", the "L", "H" mode of ⑦, ⑧ is inverted, so it is set in reverse to the state before the T/S SW is pressed. (For example: TAPE → SOURCE)

Note 1. The analog SW (pins 5, 6, 8, pins 9, 11, 12) of IC15D are selected according to the inputs (pins 14, 15).

2. When the mechanism control is operating in other modes than the above, 0-TAPE and 0-SOURCE are not output.

T/S selection

	(POWER ON) ①	(T/S 1 PUSH) ②	(T/S 1 PUSH) ③	(REC/SW ON) ④	(REC+PLAY/SW ON) ⑤
①	L	(\square)	(\square)	L	L
②	L	(\square)	(\square)	L	L
③	L	L	L	L	(\square)
④	L	L	L	(\square)	L
⑤	(\square)	L	L	L	(\square)
⑥	L	L	L	(\square)	L
⑦	H	L	H	L	H
⑧	L	H	L	H	L
⑨	(\square)	L	(\square)	L	(\square)
⑩	L	(\square)	L	(\square)	L
⑪	L	H	L	H	L
⑫	H	L	H	L	H
⑬	(\square)	(L)	(\square)	L	L

3. Auto REC level by use of electronic VR

Outline

An electronic VR is used to set the record level in this unit. This electronic VR attenuates in 2 dB steps, from 0 dB to -66 dB, and the FL indicator lights in 10 steps corresponding to the attenuation level.

The operation is changed by one step (2 dB) each time the button is pressed and is varied continuously when the button is kept pressed.

Next, the auto REC level is the system to control the above electronic VR operation automatically.

This system sets the recording level to the optimum level matching with the tape used when inputting the maximum level while the automatic switch is pressed.

Block diagram

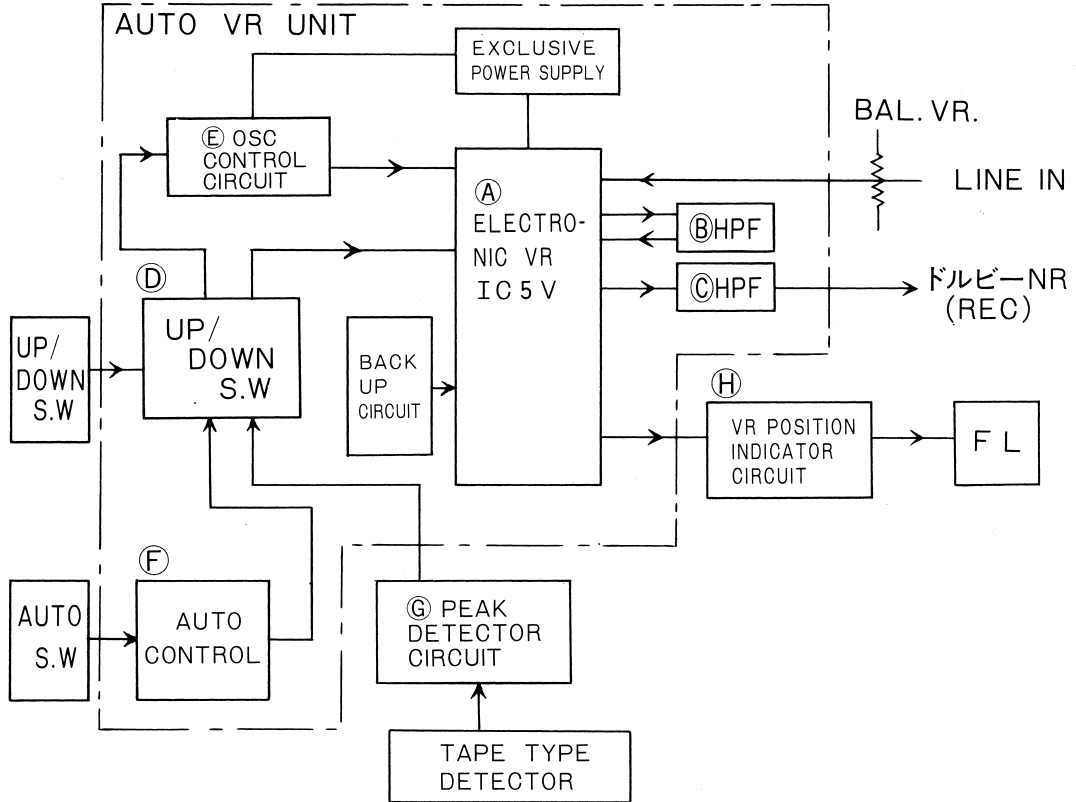

3-1. IC pin description

3-1-1. Pin arrangement

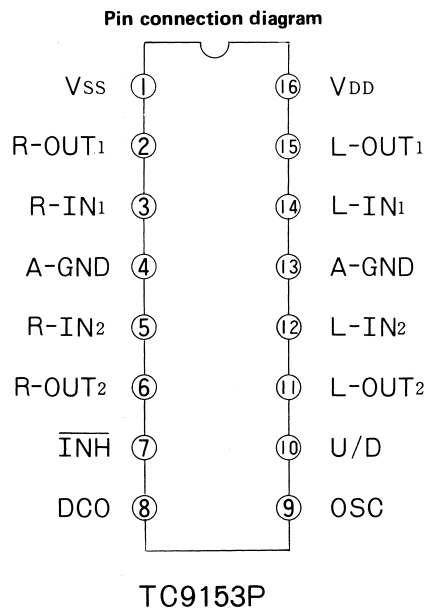

3-1-2. Pin function IC5V

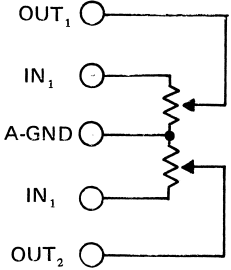
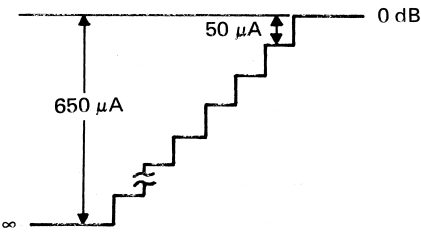
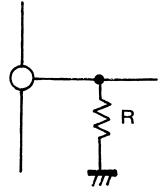
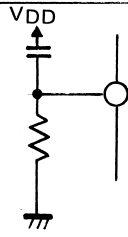
Pin No.	Mark	Function	Remarks
2 15	R-OUT ₁ L-OUT ₁	10 dB-step attenuator outputs Signal applied to IN is attenuated in 7 steps, 0 – 60 dB in 10 dB steps.	<p>L, R Symmetry</p> 
3 14	R-IN ₁ L-IN ₁	10 dB-step attenuator inputs	
4 13	A-GND	GND pins	
5 12	R-IN ₂ L-IN ₂	2 dB-step attenuator inputs	
6 11	R-OUT ₂ L-OUT ₂	2 dB-step attenuator outputs Signal applied to IN is attenuated in 5 steps, 0 – 8 dB in 2 dB steps.	
7	INH	INHIBIT pin When this pin is set to "L", all input/output are shut off setting the INHIBIT mode. (STATE HOLDING) Normal operation in "H" level.	
8	DCO	Attenuation quantity indicator DC current output. Attenuation quantity 0 – ∞ is classified into 13 steps and current of approx. 50 μA/step is output.	  <p>* Attenuation quantity can be made symmetrical to the DC voltage by inserting a resistor between this pin and GND.</p>
9	OSC	Oscillator C.R. connection pin This is the attenuation quantity UP/DOWN control oscillator, and the UP/DOWN speed is determined by its time constant.	

3-1.3. Block diagram (TC 9153P)

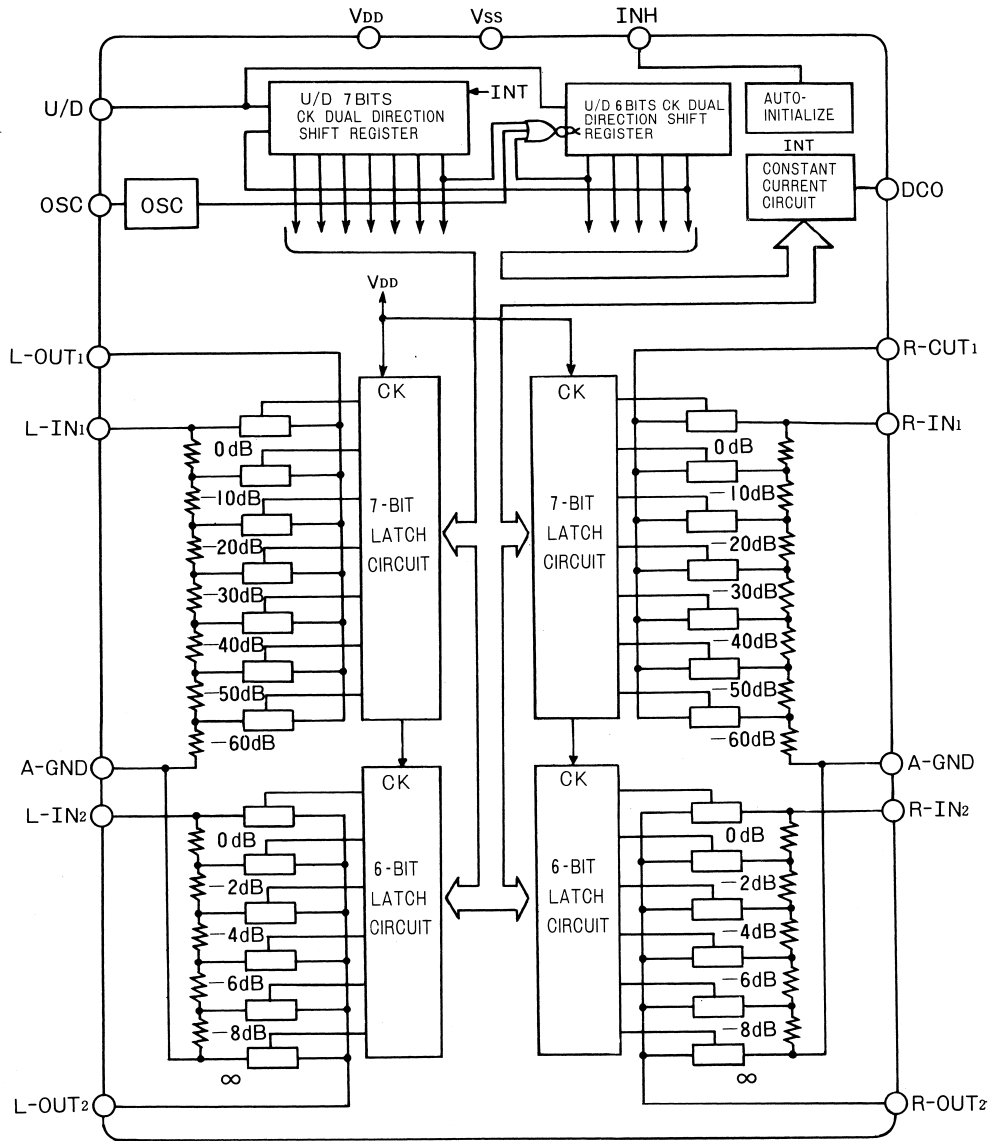

3-1.4. IC3V Relation between attenuation value and VR position

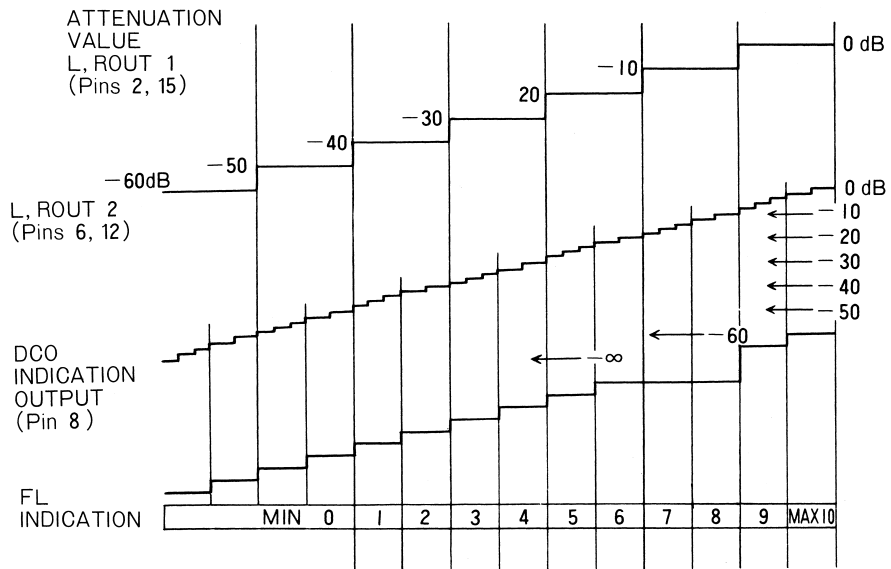

3-2. Description of each block

A Electronic VR IC, IC5V

- (1) The outputs (pins 6, 11) are changed by the UP/DOWN SW (1 push/2 dB) to LINE IN (pins 3, 14).
- (2) The UP position indication (pin 8) is changed by DC current output in 13 steps, and 10 steps are indicated by the FL display.
- (3) U/D (pin 10) controls the variation in the DOWN direction when the pin is set to "L", and in the UP direction when the pin is set to "H" or with no input.
- (4) OSC (pin 9) is oscillated via the external CR and the output is changed by 1 step (2 dB) every time the pin changes from "L" to "H".
- (5) INH (pin 7) is set to "H" with power ON and "L" with power OFF. Input/output is inhibited when it is set to "L" to maintain the back-up mode.
- (6) Pins 4, 13 supply 1/2 of the voltage supplied to IC.

B HPF: $f_0 \cong 16$ Q = 0.8 Active filter

This is installed in the IC5V (pins 2, 15) 10 dB-step attenuator output. The HPF is installed so that the low frequency noise component contained in the source is not mixed in the AUTO DOLBY signal (7 Hz, 9 Hz).

C HPF: This is installed in the IC5V (pins 6, 11) 2 dB-step attenuator output for the same purpose as in B.

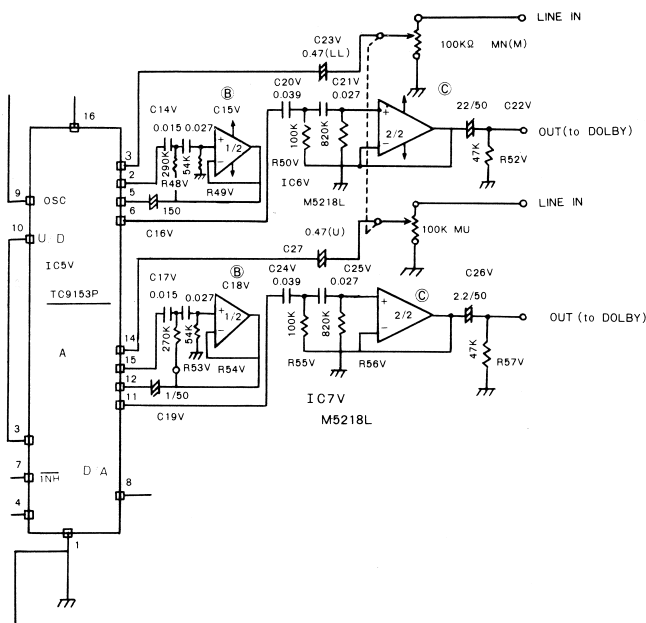

- D UP/DOWN control circuit
- E OSC control circuit
- F AUTO control circuit

Refer to the circuit diagram on the separate sheet.

3-3. Circuit operations

3-3-1. UP operation (MANUAL)

- i) ① is set to "L" with AUTO SW open
- ii) ② is set to "H", ③ to "H" and ④ to "L".
- iii) ② is set to "H" with UP SW pressed, so ⑤ is set to "H".
- iv) ⑫ is set to "H" and ⑭ to "L" regardless of the state of ④.
- v) ⑥ is set to "L" as DOWN SW is set open.
- vi) ② is set to "H", so ⑧ is set to "L", ⑨ to "H" regardless of the condition of ⑦, and 10 to "H", so, ⑪ is set to "L".
- vii) ⑬ is set to "L", and ⑭ to "L" as seen in v), vi), so ⑮ is set to "H".
- viii) IC5V pin 10 has no input and determines the UP direction mode.

- ix) At the same time, ⑤ is set to "H", so ⑱ is set to "H", ⑲ to "L" and Q4V is set to ON and ⑰ to "H" and ⑳ to "L".
- x) When ⑳ is set to "L" from "H" as shown above, ㉑ ~ ㉕ are set as follows and input to TC9153P pin 9.

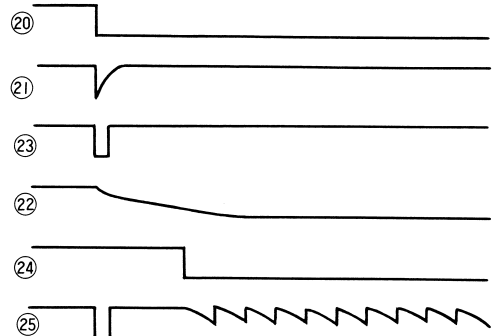

PUSH operation →

Continuous operation → (when pressed continuously)



3-3-2. DOWN operation (MANUAL)

- i) Same as UP operation
- ii) Same as UP operation
- iii) ⑥ is set to "H" with DOWN SW pressed.
- iv) ⑬ is set to "H" and ⑮ to "L" regardless of the state of 11.
- v) ⑤ is set to "L" as UP SW is open.
- vi) ④ is set to "L" because of ii).
- vii) ⑫ is set to "L", ⑮ to "L" as shown in v), vi), so ⑭ is set to "H".
- viii) IC5V pin 10 is set to "L" and determines the DOWN direction.
- ix) At the same time, as ⑥ is set to "H", ⑱ is set to "H"; it matches the condition during UP operation and the same subsequent operation is done.

3-3-3. AUTO circuit operation (before peak detection)

- i) 0-REC is set to "L" during REC, and when AUTO SW is pressed, ① is set to "H", ② to "L", ③ is set to and ④ to ("H" for a specified time).
- ii) As ② is set to "L", MANUAL UP/DOWN operations are not done, and ⑤, ⑥ are set to "L".
- iii) ⑫ is set to "H" and ⑭ to "L" while ④ is set to "H".
- iv) ⑧ is set "L", ⑨ to "H", ⑩ to "H" and ⑪ to "L" while peak detector circuit G output ⑦ is "H".
- v) ⑬ is set to "L" as shown in ii), iv) and ⑭ to "L" as shown in iii), so ⑮ is set to "H".
- vi) IC5V pin 10 is set to no input, and determined the UP direction mode.
- vii) ② is set to "L" as shown in i), ⑭ to "L" as shown in iii) and ⑯ to "H" and ⑰ to "H"
- viii) 20 is set to "L" becoming the same operation as in x) in the UP operation.

3-3.4. AUTO circuit operation (after peak detection)

- i) When peak detection is done after operation (3), ⑦ is set to "L".
- ii) ② is set to "L", so ⑧ is set to "H", ⑨ to "L".
- iii) Pin 10 is set to  and ⑪ to  (Monostable multivibrator).
- iv) ⑬ is set to "H" and ⑮ to "L" while ⑪ is set to "H".
- v) IC5V pin 10 is set to "L", and determines the DOWN direction mode.
- vi) When the time ⑦ is set to "L" is longer than the time ⑪ is set to "H" in iii), ⑧ being "H" directly sets ⑰ to "H".
- vii) ⑳ is set to "L" causing the same operation as the continuous operation in x) in the UP operation, and the REC LEVEL drops.
- viii) When REC drops to the point where peak does not appear, ⑦ is set to "H". As a result, ⑧ is set to "L", ⑰ to "L" and ⑳ is set to "H" and the DOWN operation stops.
- ix) The time ⑦ is set to "L" is shorter than the time ⑪ is set to "H" in iii), ⑰ is set to "H" for the time ⑪ is set to "H", and ㉑ is set to "L".
- x) ㉒ is set to "L" for a certain time, it becomes same as in the 1-push operation is x) in the up operation, and performs 1-step (2 dB) DOWN operation.

3-3.5. Peak detector circuit operation

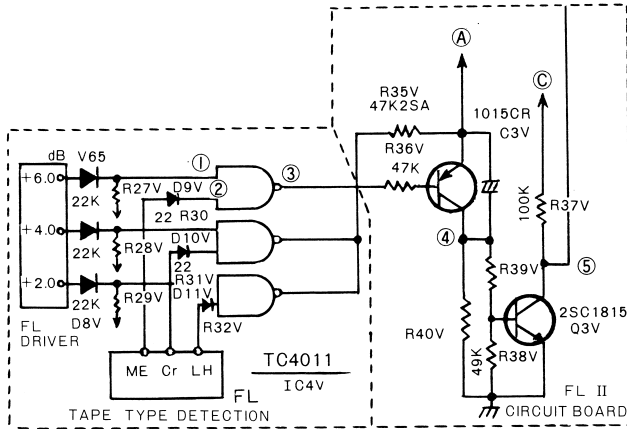

The detection peak values are set to METAL: +6 dB, CrO₂: +4 dB, and NORMAL: +2 dB to set the best level according to the type of tape.

(Example)

AUTO operation with METAL tape

- i) METAL ② is set to "H" by tape type detection
- ii) ① is set to "H" when the peak value exceeds +6 dB.
- iii) ③ is set to "L" Q2V to ON and ④ to "H".
- iv) Q3V is set to ON, ⑤ to "L" and the peak detection circuit output is set to "L". The operation is the same when CrO₂ and NORMAL tapes are used.

3-3.6. VR position indicator circuit operation

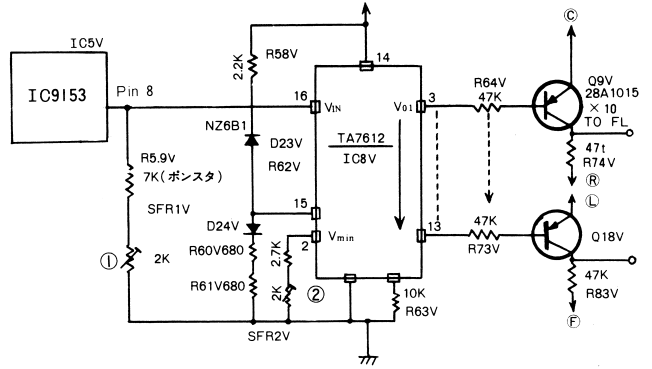

- i) IC5V (pin 8) output is 13-step output with DC current. 10 steps from a MAX of these are used to light FLs 1 to 10.
*IC5V (pin 8) output current is uneven, so it is adjusted via SFR1V, (SFR2K), SFR2V, (SFR2K).
Max 10 are adjusted by SFR1V, and SFR2V is adjusted at the 20-push point (-40 dB).

TA7612AP

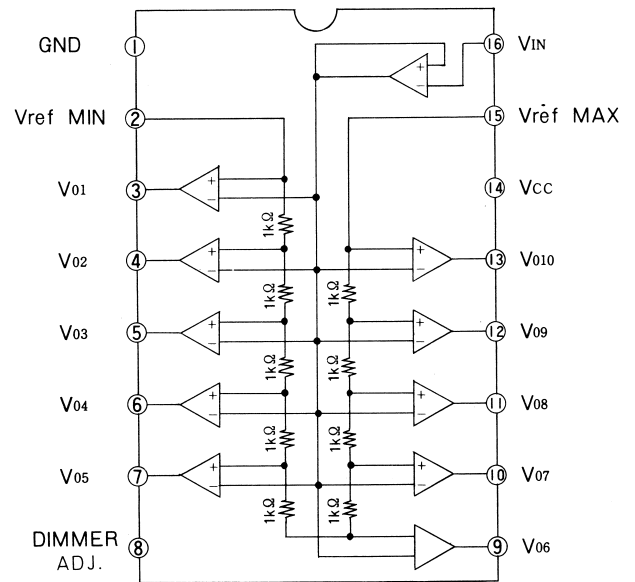

3-4. Outline of operation (Timing chart)

Refer to the separate circuit diagram for the values shown inside the circles.

3-4-1. AUTOMATIC

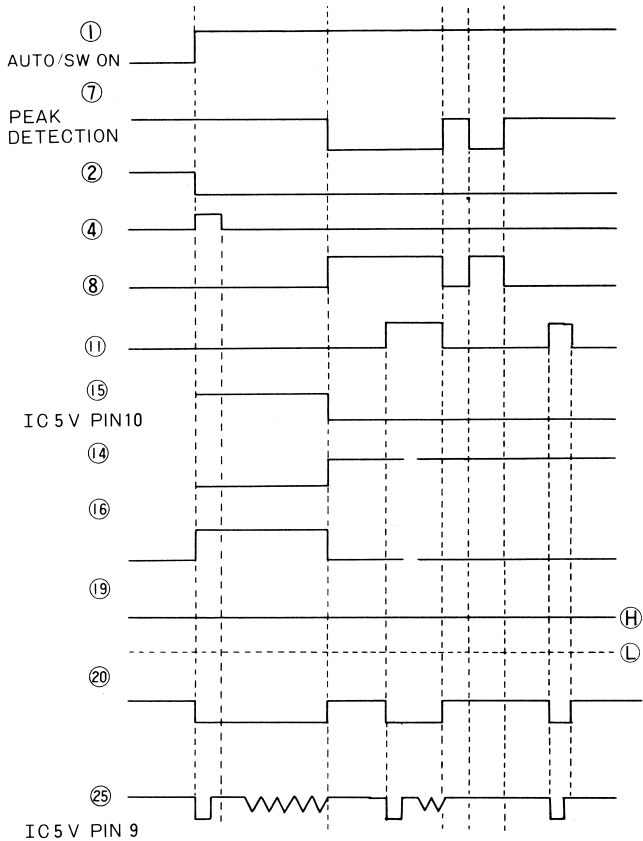

3-4-2. UP

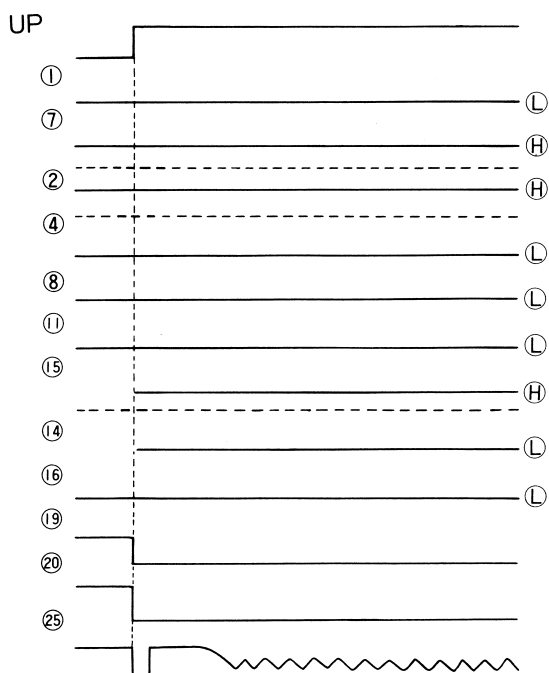

3-4-3. DOWN

*Only known that pins ⑤, ⑥ are UP.

DOWN

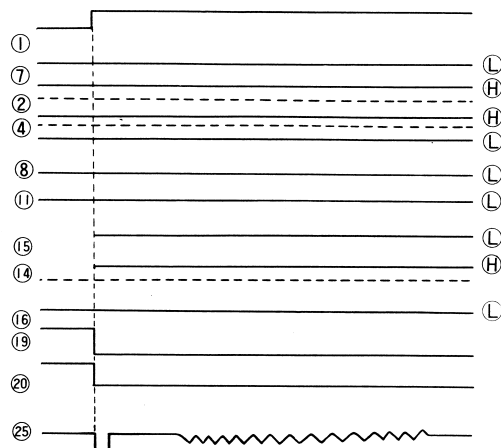

4. FL Bar meter circuit

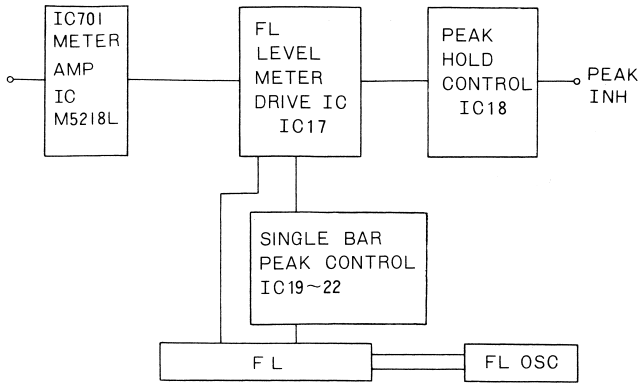

4-1. FL level meter drive IC

The FL level meter drive IC17 dynamically drives 18 points each in 2 (L, R) channels, totalling 36 points, and in addition, is provided with function to peak-hold at levels -8 dB or higher. Relation between the lighting level and IC pins is as follows.

Pin No.	6	7	8	9	10	11	12	13	14	Pin
Lighting level	-20	-15	-10	-8	-6	-4	-3	-2	-1	dB

Pin No.	15	16	17	18	19	20	21	22	23	Pin
Lighting level	0	+1	+2	+3	+4	+5	+6	+8	+10	dB

The dynamic system is applied to the inputs of IC17 pins 27, 28, and they are selected by operating the internal oscillator via C34. This selection pulse appears at pins ④ and ⑤, and when they are set to "H" (+5V) respectively, the channel of the FL connected to each pin lights.

4-2. Peak hold control section.

When IC17 pin ⑭ drops to "L" (-15 V), the peak hold is reset and it continues while the pin is set to "H" (0V). This control section generates the pulse as shown below and is set to "L" at the interval of approx. 4 sec and is then reset. This circuit is provided with the PEAK INH (peak inhibit) pin; when this pin is set to "H", Tr is set to ON and the PEAK HOLD keeps the reset mode.

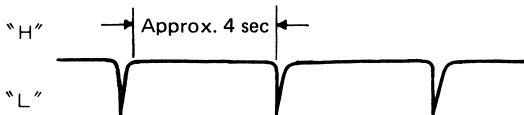

The PEAK INH circuit is peak-reset during the AUTO VR operation, so the pin is set to "H" for the time being.

4-3. Single bar PEAK section

(Relation between the FL bar meter and FL pin)

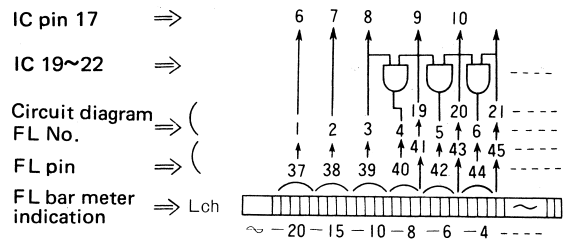

The bar meter lighting system is as follows.

When IC17 pin ⑥ is set to "H", the FL pin ⑳ is set to "H" and 4 bars (-20 dB \times 4) of the bar meter indicators are lit simultaneously. When IC17 pin ⑧ is set to "H", 4 bars (-10 dB \times 4) are lit in the same way and both the -15 dB and -20 dB bars are lit at this time. When IC17 pin ⑨ is set to "H", the FL pin ㉑ is set to "H" and only one bar between -8 dB and -6 dB is lit. Moreover, pin ⑧ is also set to "H" at that time, both inputs of the AND circuit (IC19-IC22) are set to "H" and the outputs are also set to "H".

Then the FL pin ㉒ is set to "H" to light 3 bars (-8 dB \times 3). One bar has been lit by pin ㉑, so 4 bars in total are lit, and then all the bars (-10 dB, -15 dB, -20 dB).

Next, when the input disappears and the unit enters the PEAK HOLD mode, only IC17 pin ⑨ is set to "H", and pins ⑧, ⑦, ⑥, are set to "L".

Only the FL pin ㉑ is set to "H" at that time, and pins ㉒, ㉓, ㉔, ㉕ are set to "L" and only one bar between -8 dB and -6 dB is lit and -8 dB is lit in peak hold.

As for the others, entirely the same operation is applied.

4-4. FL OSC

The FL OSC is composed of the push-pull oscillator (approx. 50 kHz) and supplies to the FL filament pins ① and ⑦⑥

■ ACCESSORIES/PACKAGE LIST

sf. No.	Part No.	Part No. Changed to	Description	Common Model	Q'ty
1	82-188-854-01		Printed indiv., Packing	*	1
2	82-188-852-01		Cushion L, Printed indiv.	*	1
3	82-188-853-01		Cushion R, Printed indiv.	*	1
4	87-051-131-11		Poly-vinyl sack (H, HU, U models only)		1
5	87-051-135-11		Poly-vinyl sack (E, K, G models only)		1
6	87-056-627-01		Poly-vinyl sack		1
7	82-190-855-01		Pad, Auxiliary	AD-F660	1
8	82-188-905-01		Instructions booklet	*	1
9	87-051-171-11		Poly-vinyl sack		1
10	87-056-008-11		Label, AC power cord (K model only)		1
11	87-056-009-51		Distributors list (H, E, K, G models only)		1
12	87-056-045-01		Guarantee card (HU, U models only)		1
13	87-056-057-01		Service station list (HU, U models only)		1
14	87-056-059-01		Guarantee card (G model only)		1
15	87-056-050-01		Safety instruction (U model only)		1
16	87-032-845-01		Siemens plug (H, HU models only)		1
17	87-034-978-01		Connection cord CW-254 BSK		2

AIWA Co., Ltd. Tokyo Japan